

Positive voltage regulators

Features

- Output current to 1.5 A
- Output voltages of 5; 6; 8; 8.5; 9; 12; 15; 18; 24 V
- Thermal overload protection
- Short circuit protection
- Output transition SOA protection

Description

The L78xx series of three-terminal positive regulators is available in TO-220, TO-220FP, TO-3, D²PAK and DPAK packages and several fixed output voltages, making it useful in a wide range of applications. These regulators can provide local on-card regulation, eliminating the distribution problems associated with single point regulation. Each type employs internal current limiting, thermal shut-down and safe area protection, making it essentially indestructible. If adequate heat sinking is provided, they can deliver over 1 A output current. Although designed primarily as fixed voltage regulators, these devices can be used with external components to obtain adjustable voltage and currents.

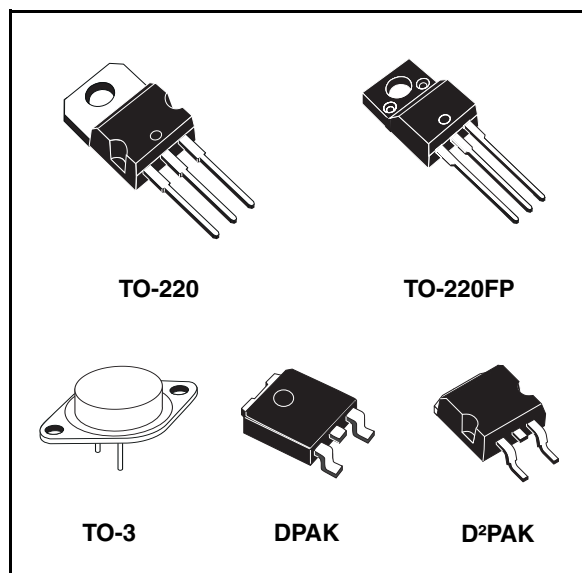

Table 1. Device summary

Part numbers	
L7805	L7809C
L7805C	L7812C
L7806C	L7815C
L7808C	L7818C
L7885C	L7824C

Contents

1	Diagram	5
2	Pin configuration	6
3	Maximum ratings	7
4	Test circuits	8
5	Electrical characteristics	9
6	Typical performance	29
7	Package mechanical data	39
8	Order codes	54
9	Revision history	55

List of figures

Figure 1.	Block diagram	5
Figure 2.	Pin connections (top view)	6
Figure 3.	Schematic diagram	6
Figure 4.	Application circuits	7
Figure 5.	DC parameter	8
Figure 6.	Load regulation	8
Figure 7.	Ripple rejection	8
Figure 8.	Dropout voltage vs junction temperature	29
Figure 9.	Peak output current vs input/output differential voltage	29
Figure 10.	Supply voltage rejection vs frequency	29
Figure 11.	Output voltage vs junction temperature	29
Figure 12.	Output impedance vs frequency	29
Figure 13.	Quiescent current vs junction temp.	29
Figure 14.	Load transient response	30
Figure 15.	Line transient response	30
Figure 16.	Quiescent current vs input voltage	30
Figure 17.	Fixed output regulator	30
Figure 18.	Current regulator	31
Figure 19.	Circuit for increasing output voltage	31
Figure 20.	Adjustable output regulator (7 to 30 V)	31
Figure 21.	0.5 to 10 V regulator	32
Figure 22.	High current voltage regulator	32
Figure 23.	High output current with short circuit protection	32
Figure 24.	Tracking voltage regulator	33
Figure 25.	Split power supply ($\pm 15\text{ V} - 1\text{ A}$)	33
Figure 26.	Negative output voltage circuit	34
Figure 27.	Switching regulator	34
Figure 28.	High input voltage circuit.	34
Figure 29.	High input voltage circuit.	35
Figure 30.	High output voltage regulator	35
Figure 31.	High input and output voltage	35
Figure 32.	Reducing power dissipation with dropping resistor	36
Figure 33.	Remote shutdown	36
Figure 34.	Power AM modulator (unity voltage gain, $I_O \leq 0.5$)	36
Figure 35.	Adjustable output voltage with temperature compensation	37
Figure 36.	Light controllers ($V_{Omin} = V_{XX} + V_{BE}$)	37
Figure 37.	Protection against input short-circuit with high capacitance loads	38
Figure 38.	Drawing dimension TO-220 (type SMIC-subcon.)	40
Figure 39.	Drawing dimension TO-220 (type STD-ST)	41
Figure 40.	Drawing dimension TO-220FP	43
Figure 41.	Drawing dimension TO-3	45
Figure 42.	Drawing dimension DPAK	46
Figure 43.	Drawing dimension tape and reel for DPAK	48
Figure 44.	Drawing dimension D ² PAK (type STD-ST)	49
Figure 45.	Drawing dimension D ² PAK (type WOOSEOK-Subcon.)	50
Figure 46.	D ² PAK footprint recommended data	52
Figure 47.	Drawing dimension tape and reel for D ² PAK	53

List of tables

Table 1.	Device summary	1
Table 2.	Absolute maximum ratings	7
Table 3.	Thermal data	7
Table 4.	Electrical characteristics of L7805	9
Table 5.	Electrical characteristics of L7806	10
Table 6.	Electrical characteristics of L7808	11
Table 7.	Electrical characteristics of L7812	12
Table 8.	Electrical characteristics of L7815	13
Table 9.	Electrical characteristics of L7818	14
Table 10.	Electrical characteristics of L7820	15
Table 11.	Electrical characteristics of L7824	16
Table 12.	Electrical characteristics of L7805C	17
Table 13.	Electrical characteristics of L7852C	18
Table 14.	Electrical characteristics of L7806C	19
Table 15.	Electrical characteristics of L7808C	20
Table 16.	Electrical characteristics of L7885C	21
Table 17.	Electrical characteristics of L7809C	22
Table 18.	Electrical characteristics of L7810C	23
Table 19.	Electrical characteristics of L7812C	24
Table 20.	Electrical characteristics of L7815C	25
Table 21.	Electrical characteristics of L7818C	26
Table 22.	Electrical characteristics of L7820C	27
Table 23.	Electrical characteristics of L7824C	28
Table 24.	TO-220 mechanical data	42
Table 25.	TO-220FP mechanical data	44
Table 26.	TO-3 mechanical data	45
Table 27.	DPAK mechanical data	47
Table 28.	Tape and reel DPAK mechanical data	48
Table 29.	D ² PAK mechanical data	51
Table 30.	D ² PAK footprint data	52
Table 31.	Tape and reel D ² PAK mechanical data	53
Table 32.	Order codes	54
Table 33.	Document revision history	55

1 Diagram

Figure 1. Block diagram

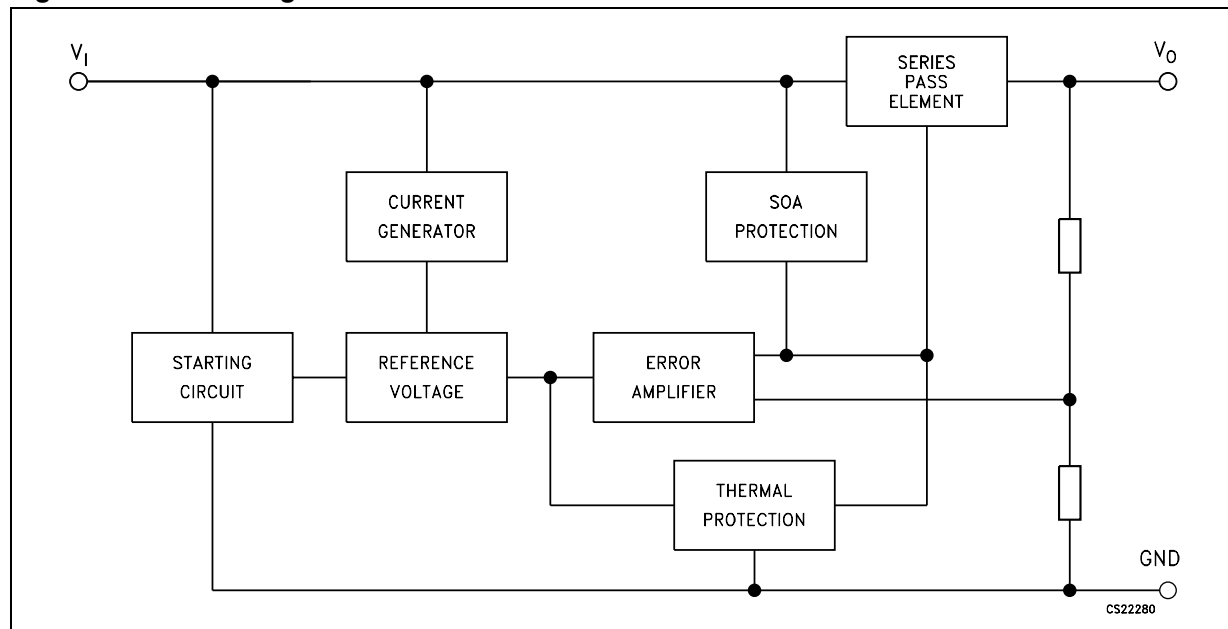

2 Pin configuration

Figure 2. Pin connections (top view)

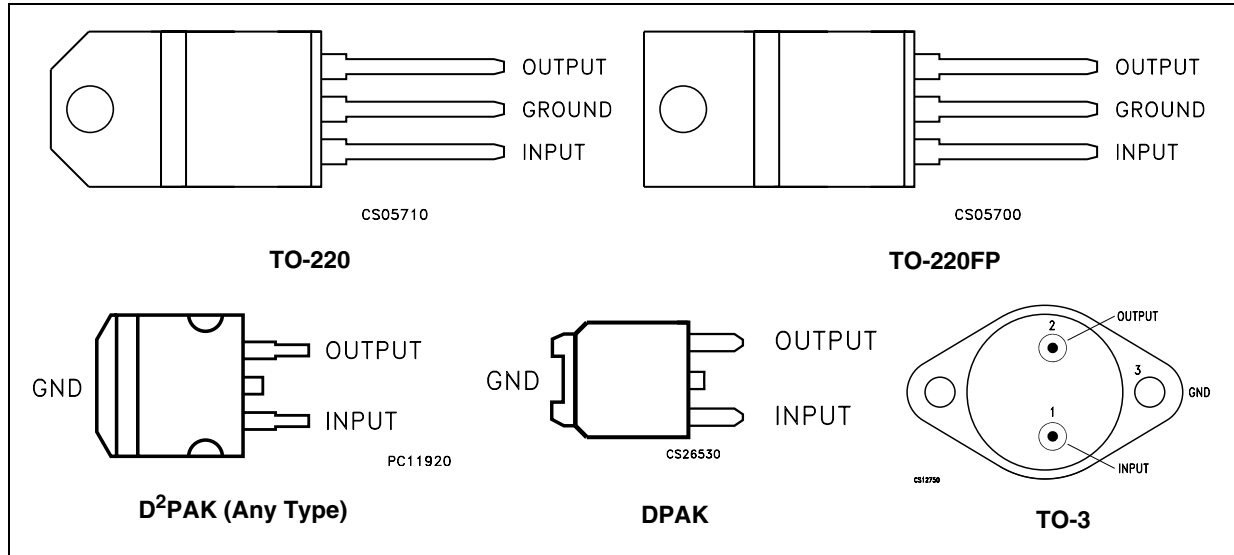
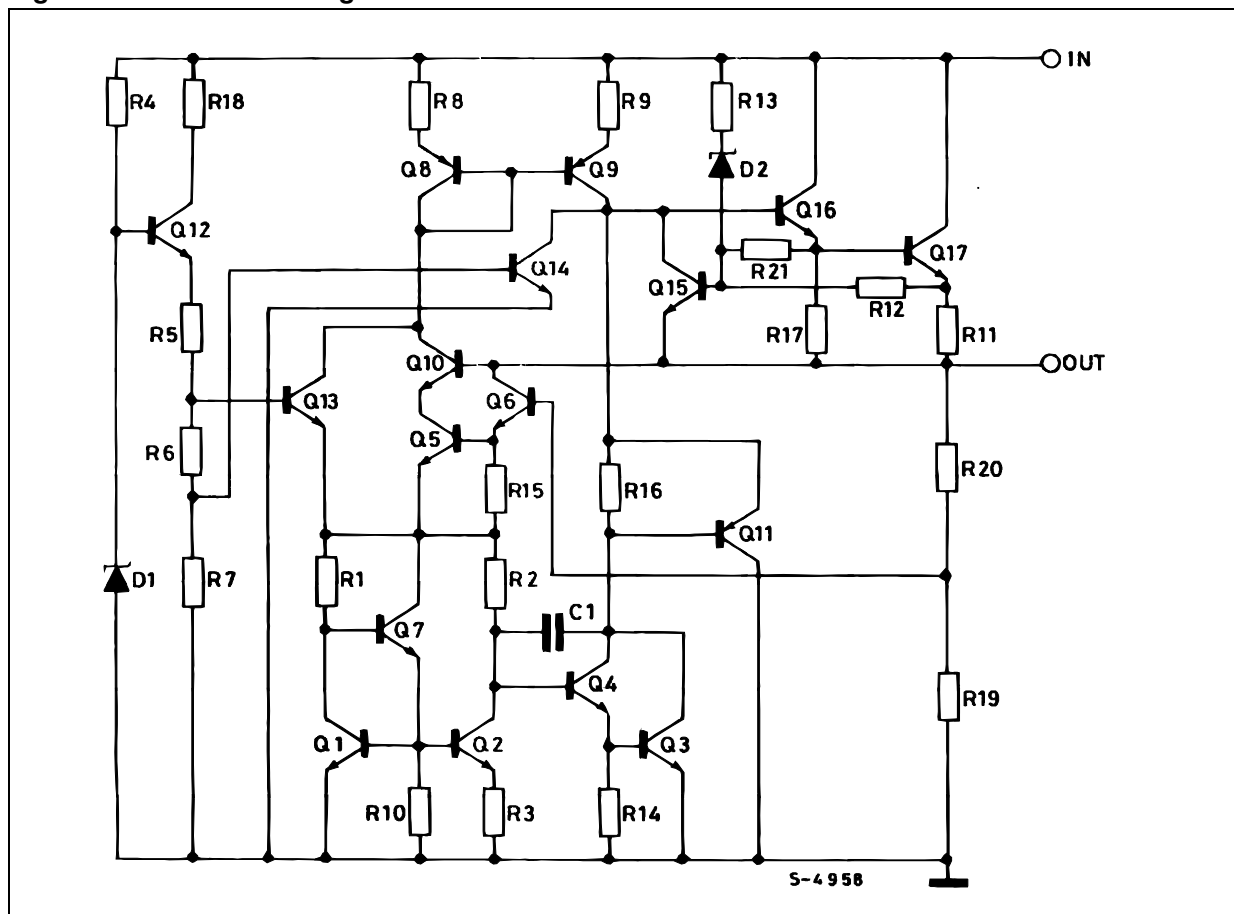

Figure 3. Schematic diagram



3 Maximum ratings

Table 2. Absolute maximum ratings

Symbol	Parameter		Value	Unit
V_I	DC input voltage	for $V_O = 5$ to 18 V	35	V
		for $V_O = 20, 24$ V	40	
I_O	Output current		Internally limited	
P_D	Power dissipation		Internally limited	
T_{STG}	Storage temperature range		-65 to 150	°C
T_{OP}	Operating junction temperature range	for L7800	-55 to 150	°C
		for L7800C	0 to 150	

Note: Absolute maximum ratings are those values beyond which damage to the device may occur. Functional operation under these condition is not implied.

Table 3. Thermal data

Symbol	Parameter	D ² PAK	DPAK	TO-220	TO-220FP	TO-3	Unit
R_{thJC}	Thermal resistance junction-case	3	8	5	5	4	°C/W
R_{thJA}	Thermal resistance junction-ambient	62.5	100	50	60	35	°C/W

Figure 4. Application circuits

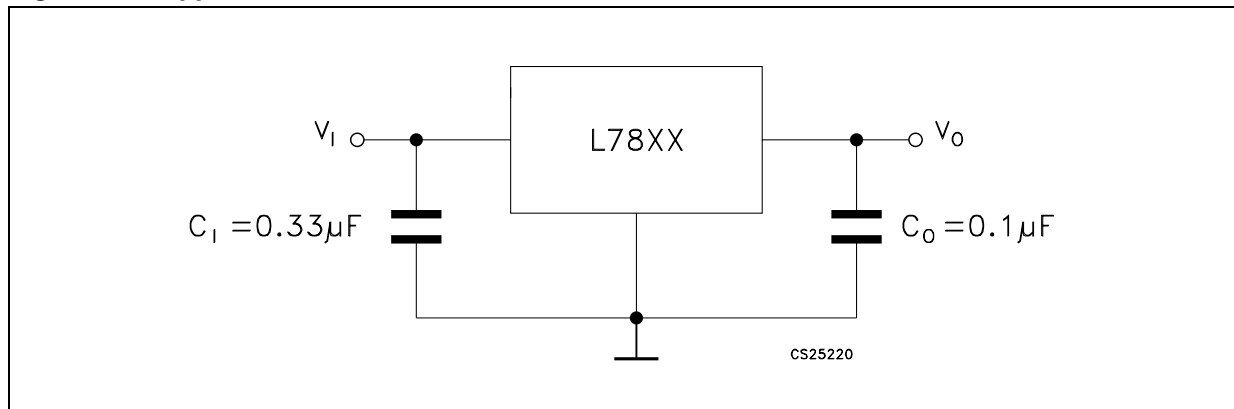

4 Test circuits

Figure 5. DC parameter

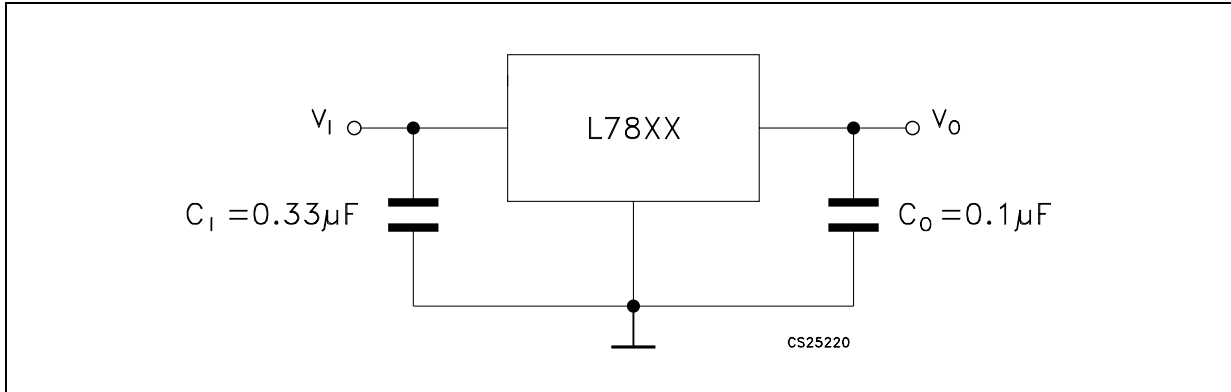

Figure 6. Load regulation

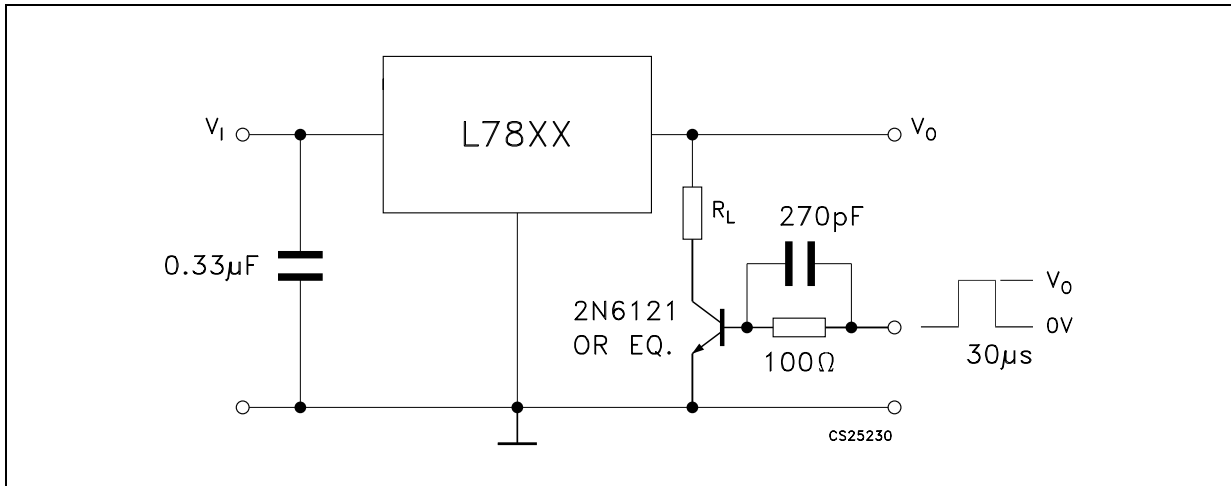
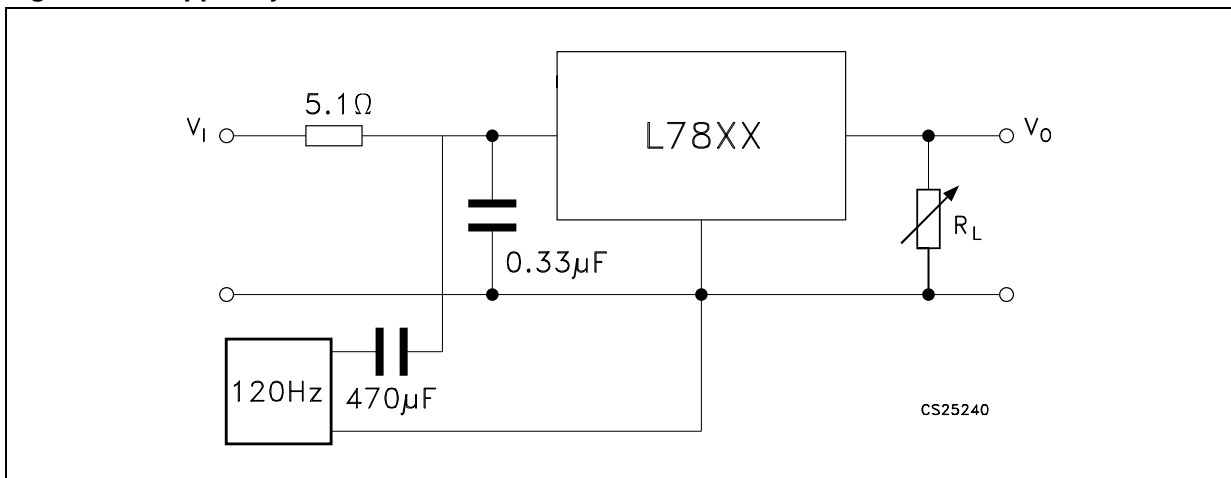

Figure 7. Ripple rejection



5 Electrical characteristics

Table 4. Electrical characteristics of L7805 (refer to the test circuits, $T_J = -55$ to 150 °C, $V_I = 10$ V, $I_O = 500$ mA, $C_I = 0.33$ μ F, $C_O = 0.1$ μ F unless otherwise specified)

Symbol	Parameter	Test conditions	Min.	Typ.	Max.	Unit
V_O	Output voltage	$T_J = 25^\circ\text{C}$	4.8	5	5.2	V
V_O	Output voltage	$I_O = 5$ mA to 1 A, $P_O \leq 15$ W $V_I = 8$ to 20 V	4.65	5	5.35	V
$\Delta V_O^{(1)}$	Line regulation	$V_I = 7$ to 25 V, $T_J = 25^\circ\text{C}$		3	50	mV
		$V_I = 8$ to 12 V, $T_J = 25^\circ\text{C}$		1	25	
$\Delta V_O^{(1)}$	Load regulation	$I_O = 5$ mA to 1.5 A, $T_J = 25^\circ\text{C}$			100	mV
		$I_O = 250$ to 750 mA, $T_J = 25^\circ\text{C}$			25	
I_d	Quiescent current	$T_J = 25^\circ\text{C}$			6	mA
ΔI_d	Quiescent current change	$I_O = 5$ mA to 1 A			0.5	mA
		$V_I = 8$ to 25 V			0.8	
$\Delta V_O/\Delta T$	Output voltage drift	$I_O = 5$ mA		0.6		mV/°C
eN	Output noise voltage	$B = 10$ Hz to 100 kHz, $T_J = 25^\circ\text{C}$			40	$\mu\text{V}/V_O$
SVR	Supply voltage rejection	$V_I = 8$ to 18 V, $f = 120$ Hz	68			dB
V_d	Dropout voltage	$I_O = 1$ A, $T_J = 25^\circ\text{C}$		2	2.5	V
R_O	Output resistance	$f = 1$ kHz		17		m Ω
I_{sc}	Short circuit current	$V_I = 35$ V, $T_J = 25^\circ\text{C}$		0.75	1.2	A
I_{scp}	Short circuit peak current	$T_J = 25^\circ\text{C}$	1.3	2.2	3.3	A

1. Load and line regulation are specified at constant junction temperature. Changes in V_O due to heating effects must be taken into account separately. Pulse testing with low duty cycle is used.

Table 5. Electrical characteristics of L7806 (refer to the test circuits, $T_J = -55$ to 150 °C, $V_I = 11$ V, $I_O = 500$ mA, $C_I = 0.33$ μ F, $C_O = 0.1$ μ F unless otherwise specified)

Symbol	Parameter	Test conditions	Min.	Typ.	Max.	Unit
V_O	Output voltage	$T_J = 25^\circ\text{C}$	5.75	6	6.25	V
V_O	Output voltage	$I_O = 5$ mA to 1 A, $P_O \leq 15$ W $V_I = 9$ to 21 V	5.65	6	6.35	V
$\Delta V_O^{(1)}$	Line regulation	$V_I = 8$ to 25 V, $T_J = 25^\circ\text{C}$			60	mV
		$V_I = 9$ to 13 V, $T_J = 25^\circ\text{C}$			30	
$\Delta V_O^{(1)}$	Load regulation	$I_O = 5$ mA to 1.5 A, $T_J = 25^\circ\text{C}$			100	mV
		$I_O = 250$ to 750 mA, $T_J = 25^\circ\text{C}$			30	
I_d	Quiescent current	$T_J = 25^\circ\text{C}$			6	mA
ΔI_d	Quiescent current change	$I_O = 5$ mA to 1 A			0.5	mA
		$V_I = 9$ to 25 V			0.8	
$\Delta V_O/\Delta T$	Output voltage drift	$I_O = 5$ mA		0.7		mV/°C
eN	Output noise voltage	$B = 10$ Hz to 100 kHz, $T_J = 25^\circ\text{C}$			40	$\mu\text{V}/V_O$
SVR	Supply voltage rejection	$V_I = 9$ to 19 V, $f = 120$ Hz	65			dB
V_d	Dropout voltage	$I_O = 1$ A, $T_J = 25^\circ\text{C}$		2	2.5	V
R_O	Output resistance	$f = 1$ kHz		19		m Ω
I_{sc}	Short circuit current	$V_I = 35$ V, $T_J = 25^\circ\text{C}$		0.75	1.2	A
I_{scp}	Short circuit peak current	$T_J = 25^\circ\text{C}$	1.3	2.2	3.3	A

1. Load and line regulation are specified at constant junction temperature. Changes in V_O due to heating effects must be taken into account separately. Pulse testing with low duty cycle is used.

Table 6. Electrical characteristics of L7808 (refer to the test circuits, $T_J = -55$ to 150 °C, $V_I = 14$ V, $I_O = 500$ mA, $C_I = 0.33$ μ F, $C_O = 0.1$ μ F unless otherwise specified)

Symbol	Parameter	Test conditions	Min.	Typ.	Max.	Unit
V_O	Output voltage	$T_J = 25^\circ\text{C}$	7.7	8	8.3	V
V_O	Output voltage	$I_O = 5$ mA to 1A, $P_O \leq 15$ W $V_I = 11.5$ to 23 V	7.6	8	8.4	V
$\Delta V_O^{(1)}$	Line regulation	$V_I = 10.5$ to 25 V, $T_J = 25^\circ\text{C}$			80	mV
		$V_I = 11$ to 17 V, $T_J = 25^\circ\text{C}$			40	
$\Delta V_O^{(1)}$	Load regulation	$I_O = 5$ mA to 1.5 A, $T_J = 25^\circ\text{C}$			100	mV
		$I_O = 250$ to 750 mA, $T_J = 25^\circ\text{C}$			40	
I_d	Quiescent current	$T_J = 25^\circ\text{C}$			6	mA
ΔI_d	Quiescent current change	$I_O = 5$ mA to 1 A			0.5	mA
		$V_I = 11.5$ to 25 V			0.8	
$\Delta V_O/\Delta T$	Output voltage drift	$I_O = 5$ mA		1		mV/°C
eN	Output noise voltage	B = 10 Hz to 100 kHz, $T_J = 25^\circ\text{C}$			40	$\mu\text{V}/V_O$
SVR	Supply voltage rejection	$V_I = 11.5$ to 21.5 V, $f = 120$ Hz	62			dB
V_d	Dropout voltage	$I_O = 1$ A, $T_J = 25^\circ\text{C}$		2	2.5	V
R_O	Output resistance	$f = 1$ kHz		16		m Ω
I_{sc}	Short circuit current	$V_I = 35$ V, $T_J = 25^\circ\text{C}$		0.75	1.2	A
I_{scp}	Short circuit peak current	$T_J = 25^\circ\text{C}$	1.3	2.2	3.3	A

1. Load and line regulation are specified at constant junction temperature. Changes in V_O due to heating effects must be taken into account separately. Pulse testing with low duty cycle is used.

Table 7. Electrical characteristics of L7812 (refer to the test circuits, $T_J = -55$ to 150 °C, $V_I = 19$ V, $I_O = 500$ mA, $C_I = 0.33$ μ F, $C_O = 0.1$ μ F unless otherwise specified)

Symbol	Parameter	Test conditions	Min.	Typ.	Max.	Unit
V_O	Output voltage	$T_J = 25^\circ\text{C}$	11.5	12	12.5	V
V_O	Output voltage	$I_O = 5$ mA to 1 A, $P_O \leq 15$ W $V_I = 15.5$ to 27 V	11.4	12	12.6	V
$\Delta V_O^{(1)}$	Line regulation	$V_I = 14.5$ to 30 V, $T_J = 25^\circ\text{C}$			120	mV
		$V_I = 16$ to 22 V, $T_J = 25^\circ\text{C}$			60	
$\Delta V_O^{(1)}$	Load regulation	$I_O = 5$ mA to 1.5 A, $T_J = 25^\circ\text{C}$			100	mV
		$I_O = 250$ to 750 mA, $T_J = 25^\circ\text{C}$			60	
I_d	Quiescent current	$T_J = 25^\circ\text{C}$			6	mA
ΔI_d	Quiescent current change	$I_O = 5$ mA to 1 A			0.5	mA
		$V_I = 15$ to 30 V			0.8	
$\Delta V_O/\Delta T$	Output voltage drift	$I_O = 5$ mA		1.5		mV/°C
eN	Output noise voltage	$B = 10$ Hz to 100 kHz, $T_J = 25^\circ\text{C}$			40	$\mu\text{V}/V_O$
SVR	Supply voltage rejection	$V_I = 15$ to 25 V, $f = 120$ Hz	61			dB
V_d	Dropout voltage	$I_O = 1$ A, $T_J = 25^\circ\text{C}$		2	2.5	V
R_O	Output resistance	$f = 1$ kHz		18		m Ω
I_{sc}	Short circuit current	$V_I = 35$ V, $T_J = 25^\circ\text{C}$		0.75	1.2	A
I_{scp}	Short circuit peak current	$T_J = 25^\circ\text{C}$	1.3	2.2	3.3	A

1. Load and line regulation are specified at constant junction temperature. Changes in V_O due to heating effects must be taken into account separately. Pulse testing with low duty cycle is used.

Table 8. Electrical characteristics of L7815 (refer to the test circuits, $T_J = -55$ to 150 °C, $V_I = 23$ V, $I_O = 500$ mA, $C_I = 0.33$ μ F, $C_O = 0.1$ μ F unless otherwise specified)

Symbol	Parameter	Test conditions	Min.	Typ.	Max.	Unit
V_O	Output voltage	$T_J = 25^\circ\text{C}$	14.4	15	15.6	V
V_O	Output voltage	$I_O = 5$ mA to 1 A, $P_O \leq 15$ W $V_I = 18.5$ to 30 V	14.25	15	15.75	V
$\Delta V_O^{(1)}$	Line regulation	$V_I = 17.5$ to 30 V, $T_J = 25^\circ\text{C}$			150	mV
		$V_I = 20$ to 26 V, $T_J = 25^\circ\text{C}$			75	
$\Delta V_O^{(1)}$	Load regulation	$I_O = 5$ mA to 1.5 A, $T_J = 25^\circ\text{C}$			150	mV
		$I_O = 250$ to 750 mA, $T_J = 25^\circ\text{C}$			75	
I_d	Quiescent current	$T_J = 25^\circ\text{C}$			6	mA
ΔI_d	Quiescent current change	$I_O = 5$ mA to 1 A			0.5	mA
		$V_I = 18.5$ to 30 V			0.8	
$\Delta V_O/\Delta T$	Output voltage drift	$I_O = 5$ mA		1.8		mV/°C
eN	Output noise voltage	B = 10 Hz to 100 kHz, $T_J = 25^\circ\text{C}$			40	$\mu\text{V}/V_O$
SVR	Supply voltage rejection	$V_I = 18.5$ to 28.5 V, $f = 120$ Hz	60			dB
V_d	Dropout voltage	$I_O = 1$ A, $T_J = 25^\circ\text{C}$		2	2.5	V
R_O	Output resistance	$f = 1$ kHz		19		m Ω
I_{sc}	Short circuit current	$V_I = 35$ V, $T_J = 25^\circ\text{C}$		0.75	1.2	A
I_{scp}	Short circuit peak current	$T_J = 25^\circ\text{C}$	1.3	2.2	3.3	A

1. Load and line regulation are specified at constant junction temperature. Changes in V_O due to heating effects must be taken into account separately. Pulse testing with low duty cycle is used.

Table 9. Electrical characteristics of L7818 (refer to the test circuits, $T_J = -55$ to 150 °C, $V_I = 26$ V, $I_O = 500$ mA, $C_I = 0.33$ μ F, $C_O = 0.1$ μ F unless otherwise specified)

Symbol	Parameter	Test conditions	Min.	Typ.	Max.	Unit
V_O	Output voltage	$T_J = 25^\circ\text{C}$	17.3	18	18.7	V
V_O	Output voltage	$I_O = 5$ mA to 1 A, $P_O \leq 15$ W $V_I = 22$ to 33 V	17.1	18	18.9	V
$\Delta V_O^{(1)}$	Line regulation	$V_I = 21$ to 33 V, $T_J = 25^\circ\text{C}$			180	mV
		$V_I = 24$ to 30 V, $T_J = 25^\circ\text{C}$			90	
$\Delta V_O^{(1)}$	Load regulation	$I_O = 5$ mA to 1.5 A, $T_J = 25^\circ\text{C}$			180	mV
		$I_O = 250$ to 750 mA, $T_J = 25^\circ\text{C}$			90	
I_d	Quiescent current	$T_J = 25^\circ\text{C}$			6	mA
ΔI_d	Quiescent current change	$I_O = 5$ mA to 1 A			0.5	mA
		$V_I = 22$ to 33 V			0.8	
$\Delta V_O/\Delta T$	Output voltage drift	$I_O = 5$ mA		2.3		mV/°C
eN	Output noise voltage	B = 10 Hz to 100 kHz, $T_J = 25^\circ\text{C}$			40	$\mu\text{V}/V_O$
SVR	Supply voltage rejection	$V_I = 22$ to 32 V, $f = 120$ Hz	59			dB
V_d	Dropout voltage	$I_O = 1$ A, $T_J = 25^\circ\text{C}$		2	2.5	V
R_O	Output resistance	$f = 1$ kHz		22		m Ω
I_{sc}	Short circuit current	$V_I = 35$ V, $T_J = 25^\circ\text{C}$		0.75	1.2	A
I_{scp}	Short circuit peak current	$T_J = 25^\circ\text{C}$	1.3	2.2	3.3	A

1. Load and line regulation are specified at constant junction temperature. Changes in V_O due to heating effects must be taken into account separately. Pulse testing with low duty cycle is used.

Table 10. Electrical characteristics of L7820 (refer to the test circuits, $T_J = -55$ to 150 °C, $V_I = 28$ V, $I_O = 500$ mA, $C_I = 0.33$ μ F, $C_O = 0.1$ μ F unless otherwise specified)

Symbol	Parameter	Test conditions	Min.	Typ.	Max.	Unit
V_O	Output voltage	$T_J = 25^\circ\text{C}$	19.2	20	20.8	V
V_O	Output voltage	$I_O = 5$ mA to 1 A, $P_O \leq 15$ W $V_I = 24$ to 35 V	19	20	21	V
$\Delta V_O^{(1)}$	Line regulation	$V_I = 22.5$ to 35 V, $T_J = 25^\circ\text{C}$			200	mV
		$V_I = 26$ to 32 V, $T_J = 25^\circ\text{C}$			100	
$\Delta V_O^{(1)}$	Load regulation	$I_O = 5$ mA to 1.5 A, $T_J = 25^\circ\text{C}$			200	mV
		$I_O = 250$ to 750 mA, $T_J = 25^\circ\text{C}$			100	
I_d	Quiescent current	$T_J = 25^\circ\text{C}$			6	mA
ΔI_d	Quiescent current change	$I_O = 5$ mA to 1 A			0.5	mA
		$V_I = 24$ to 35 V			0.8	
$\Delta V_O/\Delta T$	Output voltage drift	$I_O = 5$ mA		2.5		mV/°C
eN	Output noise voltage	$B = 10$ Hz to 100 kHz, $T_J = 25^\circ\text{C}$			40	$\mu\text{V}/V_O$
SVR	Supply voltage rejection	$V_I = 24$ to 35 V, $f = 120$ Hz	58			dB
V_d	Dropout voltage	$I_O = 1$ A, $T_J = 25^\circ\text{C}$		2	2.5	V
R_O	Output resistance	$f = 1$ kHz		24		m Ω
I_{sc}	Short circuit current	$V_I = 35$ V, $T_J = 25^\circ\text{C}$		0.75	1.2	A
I_{scp}	Short circuit peak current	$T_J = 25^\circ\text{C}$	1.3	2.2	3.3	A

1. Load and line regulation are specified at constant junction temperature. Changes in V_O due to heating effects must be taken into account separately. Pulse testing with low duty cycle is used.

Table 11. Electrical characteristics of L7824 (refer to the test circuits, $T_J = -55$ to 150 °C, $V_I = 33$ V, $I_O = 500$ mA, $C_I = 0.33$ μ F, $C_O = 0.1$ μ F unless otherwise specified)

Symbol	Parameter	Test conditions	Min.	Typ.	Max.	Unit
V_O	Output voltage	$T_J = 25^\circ\text{C}$	23	24	25	V
V_O	Output voltage	$I_O = 5$ mA to 1 A, $P_O \leq 15$ W $V_I = 28$ to 38 V	22.8	24	25.2	V
$\Delta V_O^{(1)}$	Line regulation	$V_I = 27$ to 38 V, $T_J = 25^\circ\text{C}$			240	mV
		$V_I = 30$ to 36 V, $T_J = 25^\circ\text{C}$			120	
$\Delta V_O^{(1)}$	Load regulation	$I_O = 5$ mA to 1.5 A, $T_J = 25^\circ\text{C}$			240	mV
		$I_O = 250$ to 750 mA, $T_J = 25^\circ\text{C}$			120	
I_d	Quiescent current	$T_J = 25^\circ\text{C}$			6	mA
ΔI_d	Quiescent current change	$I_O = 5$ mA to 1 A			0.5	mA
		$V_I = 28$ to 38 V			0.8	
$\Delta V_O/\Delta T$	Output voltage drift	$I_O = 5$ mA		3		mV/°C
eN	Output noise voltage	B = 10 Hz to 100 kHz, $T_J = 25^\circ\text{C}$			40	$\mu\text{V}/V_O$
SVR	Supply voltage rejection	$V_I = 28$ to 38 V, $f = 120$ Hz	56			dB
V_d	Dropout voltage	$I_O = 1$ A, $T_J = 25^\circ\text{C}$		2	2.5	V
R_O	Output resistance	$f = 1$ kHz		28		m Ω
I_{sc}	Short circuit current	$V_I = 35$ V, $T_J = 25^\circ\text{C}$		0.75	1.2	A
I_{scp}	Short circuit peak current	$T_J = 25^\circ\text{C}$	1.3	2.2	3.3	A

1. Load and line regulation are specified at constant junction temperature. Changes in V_O due to heating effects must be taken into account separately. Pulse testing with low duty cycle is used.

Table 12. Electrical characteristics of L7805C (refer to the test circuits, $T_J = 0$ to 150 °C, $V_I = 10$ V, $I_O = 500$ mA, $C_I = 0.33$ μ F, $C_O = 0.1$ μ F unless otherwise specified)

Symbol	Parameter	Test conditions	Min.	Typ.	Max.	Unit
V_O	Output voltage	$T_J = 25^\circ\text{C}$	4.8	5	5.2	V
V_O	Output voltage	$I_O = 5$ mA to 1 A, $P_O \leq 15$ W $V_I = 7$ to 20 V	4.75	5	5.25	V
$\Delta V_O^{(1)}$	Line regulation	$V_I = 7$ to 25 V, $T_J = 25^\circ\text{C}$		3	100	mV
		$V_I = 8$ to 12 V, $T_J = 25^\circ\text{C}$		1	50	
$\Delta V_O^{(1)}$	Load regulation	$I_O = 5$ mA to 1.5 A, $T_J = 25^\circ\text{C}$			100	mV
		$I_O = 250$ to 750 mA, $T_J = 25^\circ\text{C}$			50	
I_d	Quiescent current	$T_J = 25^\circ\text{C}$			8	mA
ΔI_d	Quiescent current change	$I_O = 5$ mA to 1 A			0.5	mA
		$V_I = 7$ to 25 V			0.8	
$\Delta V_O/\Delta T$	Output voltage drift	$I_O = 5$ mA		-1.1		mV/°C
eN	Output noise voltage	B = 10 Hz to 100 kHz, $T_J = 25^\circ\text{C}$		40		$\mu\text{V}/V_O$
SVR	Supply voltage rejection	$V_I = 8$ to 18 V, $f = 120$ Hz	62			dB
V_d	Dropout voltage	$I_O = 1$ A, $T_J = 25^\circ\text{C}$		2		V
R_O	Output resistance	$f = 1$ kHz		17		m Ω
I_{sc}	Short circuit current	$V_I = 35$ V, $T_J = 25^\circ\text{C}$		0.75		A
I_{scp}	Short circuit peak current	$T_J = 25^\circ\text{C}$		2.2		A

1. Load and line regulation are specified at constant junction temperature. Changes in V_O due to heating effects must be taken into account separately. Pulse testing with low duty cycle is used.

Table 13. Electrical characteristics of L7852C (refer to the test circuits, $T_J = 0$ to $150\text{ }^\circ\text{C}$, $V_I = 10\text{ V}$, $I_O = 500\text{ mA}$, $C_I = 0.33\text{ }\mu\text{F}$, $C_O = 0.1\text{ }\mu\text{F}$ unless otherwise specified)

Symbol	Parameter	Test conditions	Min.	Typ.	Max.	Unit
V_O	Output voltage	$T_J = 25^\circ\text{C}$	5.0	5.2	5.4	V
V_O	Output voltage	$I_O = 5\text{ mA to }1\text{ A}$, $P_O \leq 15\text{ W}$ $V_I = 8\text{ to }20\text{ V}$	4.95	5.2	5.45	V
$\Delta V_O^{(1)}$	Line regulation	$V_I = 7\text{ to }25\text{ V}$, $T_J = 25^\circ\text{C}$		3	105	mV
		$V_I = 8\text{ to }12\text{ V}$, $T_J = 25^\circ\text{C}$		1	52	
$\Delta V_O^{(1)}$	Load regulation	$I_O = 5\text{ mA to }1.5\text{ A}$, $T_J = 25^\circ\text{C}$			105	mV
		$I_O = 250\text{ to }750\text{ mA}$, $T_J = 25^\circ\text{C}$			52	
I_d	Quiescent current	$T_J = 25^\circ\text{C}$			8	mA
ΔI_d	Quiescent current change	$I_O = 5\text{ mA to }1\text{ A}$			0.5	mA
		$V_I = 7\text{ to }25\text{ V}$			1.3	
$\Delta V_O/\Delta T$	Output voltage drift	$I_O = 5\text{ mA}$		-1		mV/ $^\circ\text{C}$
eN	Output noise voltage	$B = 10\text{ Hz to }100\text{ kHz}$, $T_J = 25^\circ\text{C}$		42		$\mu\text{V}/V_O$
SVR	Supply voltage rejection	$V_I = 8\text{ to }18\text{ V}$, $f = 120\text{ Hz}$	61			dB
V_d	Dropout voltage	$I_O = 1\text{ A}$, $T_J = 25^\circ\text{C}$		2		V
R_O	Output resistance	$f = 1\text{ kHz}$		17		m Ω
I_{sc}	Short circuit current	$V_I = 35\text{ V}$, $T_J = 25^\circ\text{C}$		0.75		A
I_{scp}	Short circuit peak current	$T_J = 25^\circ\text{C}$		2.2		A

1. Load and line regulation are specified at constant junction temperature. Changes in V_O due to heating effects must be taken into account separately. Pulse testing with low duty cycle is used.

Table 14. Electrical characteristics of L7806C (refer to the test circuits, $T_J = 0$ to 150 °C, $V_I = 11$ V, $I_O = 500$ mA, $C_I = 0.33$ μ F, $C_O = 0.1$ μ F unless otherwise specified)

Symbol	Parameter	Test conditions	Min.	Typ.	Max.	Unit
V_O	Output voltage	$T_J = 25^\circ\text{C}$	5.75	6	6.25	V
V_O	Output voltage	$I_O = 5$ mA to 1 A, $P_O \leq 15$ W $V_I = 8$ to 21 V	5.7	6	6.3	V
$\Delta V_O^{(1)}$	Line regulation	$V_I = 8$ to 25 V, $T_J = 25^\circ\text{C}$			120	mV
		$V_I = 9$ to 13 V, $T_J = 25^\circ\text{C}$			60	
$\Delta V_O^{(1)}$	Load regulation	$I_O = 5$ mA to 1.5 A, $T_J = 25^\circ\text{C}$			120	mV
		$I_O = 250$ to 750 mA, $T_J = 25^\circ\text{C}$			60	
I_d	Quiescent current	$T_J = 25^\circ\text{C}$			8	mA
ΔI_d	Quiescent current change	$I_O = 5$ mA to 1 A			0.5	mA
		$V_I = 8$ to 25 V			1.3	
$\Delta V_O/\Delta T$	Output voltage drift	$I_O = 5$ mA		-0.8		mV/°C
eN	Output noise voltage	$B = 10$ Hz to 100 kHz, $T_J = 25^\circ\text{C}$		45		$\mu\text{V}/V_O$
SVR	Supply voltage rejection	$V_I = 9$ to 19 V, $f = 120$ Hz	59			dB
V_d	Dropout voltage	$I_O = 1$ A, $T_J = 25^\circ\text{C}$		2		V
R_O	Output resistance	$f = 1$ kHz		19		m Ω
I_{sc}	Short circuit current	$V_I = 35$ V, $T_J = 25^\circ\text{C}$		0.55		A
I_{scp}	Short circuit peak current	$T_J = 25^\circ\text{C}$		2.2		A

1. Load and line regulation are specified at constant junction temperature. Changes in V_O due to heating effects must be taken into account separately. Pulse testing with low duty cycle is used.

Table 15. Electrical characteristics of L7808C (refer to the test circuits, $T_J = 0$ to 150 °C, $V_I = 14$ V, $I_O = 500$ mA, $C_I = 0.33$ μ F, $C_O = 0.1$ μ F unless otherwise specified)

Symbol	Parameter	Test conditions	Min.	Typ.	Max.	Unit
V_O	Output voltage	$T_J = 25^\circ\text{C}$	7.7	8	8.3	V
V_O	Output voltage	$I_O = 5$ mA to 1 A, $P_O \leq 15$ W $V_I = 10.5$ to 25 V	7.6	8	8.4	V
$\Delta V_O^{(1)}$	Line regulation	$V_I = 10.5$ to 25 V, $T_J = 25^\circ\text{C}$			160	mV
		$V_I = 11$ to 17 V, $T_J = 25^\circ\text{C}$			80	
$\Delta V_O^{(1)}$	Load regulation	$I_O = 5$ mA to 1.5 A, $T_J = 25^\circ\text{C}$			160	mV
		$I_O = 250$ to 750 mA, $T_J = 25^\circ\text{C}$			80	
I_d	Quiescent current	$T_J = 25^\circ\text{C}$			8	mA
ΔI_d	Quiescent current change	$I_O = 5$ mA to 1 A			0.5	mA
		$V_I = 10.5$ to 25 V			1	
$\Delta V_O/\Delta T$	Output voltage drift	$I_O = 5$ mA		-0.8		mV/°C
eN	Output noise voltage	B = 10 Hz to 100 kHz, $T_J = 25^\circ\text{C}$		52		$\mu\text{V}/V_O$
SVR	Supply voltage rejection	$V_I = 11.5$ to 21.5 V, $f = 120$ Hz	56			dB
V_d	Dropout voltage	$I_O = 1$ A, $T_J = 25^\circ\text{C}$		2		V
R_O	Output resistance	$f = 1$ kHz		16		m Ω
I_{sc}	Short circuit current	$V_I = 35$ V, $T_J = 25^\circ\text{C}$		0.45		A
I_{scp}	Short circuit peak current	$T_J = 25^\circ\text{C}$		2.2		A

1. Load and line regulation are specified at constant junction temperature. Changes in V_O due to heating effects must be taken into account separately. Pulse testing with low duty cycle is used.

Table 16. Electrical characteristics of L7885C (refer to the test circuits, $T_J = 0$ to $150\text{ }^\circ\text{C}$, $V_I = 14.5\text{ V}$, $I_O = 500\text{ mA}$, $C_I = 0.33\text{ }\mu\text{F}$, $C_O = 0.1\text{ }\mu\text{F}$ unless otherwise specified)

Symbol	Parameter	Test conditions	Min.	Typ.	Max.	Unit
V_O	Output voltage	$T_J = 25^\circ\text{C}$	8.2	8.5	8.8	V
V_O	Output voltage	$I_O = 5\text{ mA to }1\text{ A}$, $P_O \leq 15\text{ W}$ $V_I = 11\text{ to }26\text{ V}$	8.1	8.5	8.9	V
$\Delta V_O^{(1)}$	Line regulation	$V_I = 11\text{ to }27\text{ V}$, $T_J = 25^\circ\text{C}$			160	mV
		$V_I = 11.5\text{ to }17.5\text{ V}$, $T_J = 25^\circ\text{C}$			80	
$\Delta V_O^{(1)}$	Load regulation	$I_O = 5\text{ mA to }1.5\text{ A}$, $T_J = 25^\circ\text{C}$			160	mV
		$I_O = 250\text{ to }750\text{ mA}$, $T_J = 25^\circ\text{C}$			80	
I_d	Quiescent current	$T_J = 25^\circ\text{C}$			8	mA
ΔI_d	Quiescent current change	$I_O = 5\text{ mA to }1\text{ A}$			0.5	mA
		$V_I = 11\text{ to }27\text{ V}$			1	
$\Delta V_O/\Delta T$	Output voltage drift	$I_O = 5\text{ mA}$		-0.8		mV/ $^\circ\text{C}$
eN	Output noise voltage	$B = 10\text{ Hz to }100\text{ kHz}$, $T_J = 25^\circ\text{C}$		55		$\mu\text{V}/V_O$
SVR	Supply voltage rejection	$V_I = 12\text{ to }22\text{ V}$, $f = 120\text{ Hz}$	56			dB
V_d	Dropout voltage	$I_O = 1\text{ A}$, $T_J = 25^\circ\text{C}$		2		V
R_O	Output resistance	$f = 1\text{ kHz}$		16		m Ω
I_{sc}	Short circuit current	$V_I = 35\text{ V}$, $T_J = 25^\circ\text{C}$		0.45		A
I_{scp}	Short circuit peak current	$T_J = 25^\circ\text{C}$		2.2		A

1. Load and line regulation are specified at constant junction temperature. Changes in V_O due to heating effects must be taken into account separately. Pulse testing with low duty cycle is used.

Table 17. Electrical characteristics of L7809C (refer to the test circuits, $T_J = 0$ to 150 °C, $V_I = 15$ V, $I_O = 500$ mA, $C_I = 0.33$ μ F, $C_O = 0.1$ μ F unless otherwise specified)

Symbol	Parameter	Test conditions	Min.	Typ.	Max.	Unit
V_O	Output voltage	$T_J = 25^\circ\text{C}$	8.64	9	9.36	V
V_O	Output voltage	$I_O = 5$ mA to 1 A, $P_O \leq 15$ W $V_I = 11.5$ to 26 V	8.55	9	9.45	V
$\Delta V_O^{(1)}$	Line regulation	$V_I = 11.5$ to 26 V, $T_J = 25^\circ\text{C}$			180	mV
		$V_I = 12$ to 18 V, $T_J = 25^\circ\text{C}$			90	
$\Delta V_O^{(1)}$	Load regulation	$I_O = 5$ mA to 1.5 A, $T_J = 25^\circ\text{C}$			180	mV
		$I_O = 250$ to 750 mA, $T_J = 25^\circ\text{C}$			90	
I_d	Quiescent current	$T_J = 25^\circ\text{C}$			8	mA
ΔI_d	Quiescent current change	$I_O = 5$ mA to 1 A			0.5	mA
		$V_I = 11.5$ to 26 V			1	
$\Delta V_O/\Delta T$	Output voltage drift	$I_O = 5$ mA		-1		mV/°C
eN	Output noise voltage	$B = 10$ Hz to 100 kHz, $T_J = 25^\circ\text{C}$		70		$\mu\text{V}/V_O$
SVR	Supply voltage rejection	$V_I = 12$ to 23 V, $f = 120$ Hz	55			dB
V_d	Dropout voltage	$I_O = 1$ A, $T_J = 25^\circ\text{C}$		2		V
R_O	Output resistance	$f = 1$ kHz		17		m Ω
I_{sc}	Short circuit current	$V_I = 35$ V, $T_J = 25^\circ\text{C}$		0.40		A
I_{scp}	Short circuit peak current	$T_J = 25^\circ\text{C}$		2.2		A

1. Load and line regulation are specified at constant junction temperature. Changes in V_O due to heating effects must be taken into account separately. Pulse testing with low duty cycle is used.

Table 18. Electrical characteristics of L7810C (refer to the test circuits, $T_J = 0$ to 150 °C, $V_I = 15$ V, $I_O = 500$ mA, $C_I = 0.33$ μ F, $C_O = 0.1$ μ F unless otherwise specified)

Symbol	Parameter	Test conditions	Min.	Typ.	Max.	Unit
V_O	Output voltage	$T_J = 25^\circ\text{C}$	9.6	10	10.4	V
V_O	Output voltage	$I_O = 5$ mA to 1 A, $P_O \leq 15$ W $V_I = 12.5$ to 26 V	9.5	10	10.5	V
$\Delta V_O^{(1)}$	Line regulation	$V_I = 12.5$ to 26 V, $T_J = 25^\circ\text{C}$			200	mV
		$V_I = 13.5$ to 19 V, $T_J = 25^\circ\text{C}$			100	
$\Delta V_O^{(1)}$	Load regulation	$I_O = 5$ mA to 1.5 A, $T_J = 25^\circ\text{C}$			200	mV
		$I_O = 250$ to 750 mA, $T_J = 25^\circ\text{C}$			100	
I_d	Quiescent current	$T_J = 25^\circ\text{C}$			8	mA
ΔI_d	Quiescent current change	$I_O = 5$ mA to 1 A			0.5	mA
		$V_I = 12.5$ to 26 V			1	
$\Delta V_O/\Delta T$	Output voltage drift	$I_O = 5$ mA		-1		mV/°C
eN	Output noise voltage	$B = 10$ Hz to 100 kHz, $T_J = 25^\circ\text{C}$		70		$\mu\text{V}/V_O$
SVR	Supply voltage rejection	$V_I = 13$ to 23 V, $f = 120$ Hz	55			dB
V_d	Dropout voltage	$I_O = 1$ A, $T_J = 25^\circ\text{C}$		2		V
R_O	Output resistance	$f = 1$ kHz		17		m Ω
I_{sc}	Short circuit current	$V_I = 35$ V, $T_J = 25^\circ\text{C}$		0.40		A
I_{scp}	Short circuit peak current	$T_J = 25^\circ\text{C}$		2.2		A

1. Load and line regulation are specified at constant junction temperature. Changes in V_O due to heating effects must be taken into account separately. Pulse testing with low duty cycle is used.

Table 19. Electrical characteristics of L7812C (refer to the test circuits, $T_J = 0$ to 150 °C, $V_I = 19$ V, $I_O = 500$ mA, $C_I = 0.33$ μ F, $C_O = 0.1$ μ F unless otherwise specified)

Symbol	Parameter	Test conditions	Min.	Typ.	Max.	Unit
V_O	Output voltage	$T_J = 25^\circ\text{C}$	11.5	12	12.5	V
V_O	Output voltage	$I_O = 5$ mA to 1 A, $P_O \leq 15$ W $V_I = 14.5$ to 27 V	11.4	12	12.6	V
$\Delta V_O^{(1)}$	Line regulation	$V_I = 14.5$ to 30 V, $T_J = 25^\circ\text{C}$			240	mV
		$V_I = 16$ to 22 V, $T_J = 25^\circ\text{C}$			120	
$\Delta V_O^{(1)}$	Load regulation	$I_O = 5$ mA to 1.5 A, $T_J = 25^\circ\text{C}$			240	mV
		$I_O = 250$ to 750 mA, $T_J = 25^\circ\text{C}$			120	
I_d	Quiescent current	$T_J = 25^\circ\text{C}$			8	mA
ΔI_d	Quiescent current change	$I_O = 5$ mA to 1 A			0.5	mA
		$V_I = 14.5$ to 30 V			1	
$\Delta V_O/\Delta T$	Output voltage drift	$I_O = 5$ mA		-1		mV/°C
eN	Output noise voltage	$B = 10$ Hz to 100 kHz, $T_J = 25^\circ\text{C}$		75		$\mu\text{V}/V_O$
SVR	Supply voltage rejection	$V_I = 15$ to 25 V, $f = 120$ Hz	55			dB
V_d	Dropout voltage	$I_O = 1$ A, $T_J = 25^\circ\text{C}$		2		V
R_O	Output resistance	$f = 1$ kHz		18		m Ω
I_{sc}	Short circuit current	$V_I = 35$ V, $T_J = 25^\circ\text{C}$		0.35		A
I_{scp}	Short circuit peak current	$T_J = 25^\circ\text{C}$		2.2		A

1. Load and line regulation are specified at constant junction temperature. Changes in V_O due to heating effects must be taken into account separately. Pulse testing with low duty cycle is used.

Table 20. Electrical characteristics of L7815C (refer to the test circuits, $T_J = 0$ to 150 °C, $V_I = 23$ V, $I_O = 500$ mA, $C_I = 0.33$ μ F, $C_O = 0.1$ μ F unless otherwise specified)

Symbol	Parameter	Test conditions	Min.	Typ.	Max.	Unit
V_O	Output voltage	$T_J = 25^\circ\text{C}$	14.5	15	15.6	V
V_O	Output voltage	$I_O = 5$ mA to 1 A, $P_O \leq 15$ W $V_I = 17.5$ to 30 V	14.25	15	15.75	V
$\Delta V_O^{(1)}$	Line regulation	$V_I = 17.5$ to 30 V, $T_J = 25^\circ\text{C}$			300	mV
		$V_I = 20$ to 26 V, $T_J = 25^\circ\text{C}$			150	
$\Delta V_O^{(1)}$	Load regulation	$I_O = 5$ mA to 1.5 A, $T_J = 25^\circ\text{C}$			300	mV
		$I_O = 250$ to 750 mA, $T_J = 25^\circ\text{C}$			150	
I_d	Quiescent current	$T_J = 25^\circ\text{C}$			8	mA
ΔI_d	Quiescent current change	$I_O = 5$ mA to 1 A			0.5	mA
		$V_I = 17.5$ to 30 V			1	
$\Delta V_O/\Delta T$	Output voltage drift	$I_O = 5$ mA		-1		mV/°C
eN	Output noise voltage	B = 10 Hz to 100kHz, $T_J = 25^\circ\text{C}$		90		$\mu\text{V}/V_O$
SVR	Supply voltage rejection	$V_I = 18.5$ to 28.5 V, $f = 120$ Hz	54			dB
V_d	Dropout voltage	$I_O = 1$ A, $T_J = 25^\circ\text{C}$		2		V
R_O	Output resistance	$f = 1$ kHz		19		m Ω
I_{sc}	Short circuit current	$V_I = 35$ V, $T_J = 25^\circ\text{C}$		0.23		A
I_{scp}	Short circuit peak current	$T_J = 25^\circ\text{C}$		2.2		A

1. Load and line regulation are specified at constant junction temperature. Changes in V_O due to heating effects must be taken into account separately. Pulse testing with low duty cycle is used.

Table 21. Electrical characteristics of L7818C (refer to the test circuits, $T_J = 0$ to 150 °C, $V_I = 26$ V, $I_O = 500$ mA, $C_I = 0.33$ μ F, $C_O = 0.1$ μ F unless otherwise specified)

Symbol	Parameter	Test conditions	Min.	Typ.	Max.	Unit
V_O	Output voltage	$T_J = 25^\circ\text{C}$	17.3	18	18.7	V
V_O	Output voltage	$I_O = 5$ mA to 1 A, $P_O \leq 15$ W $V_I = 21$ to 33 V	17.1	18	18.9	V
$\Delta V_O^{(1)}$	Line regulation	$V_I = 21$ to 33 V, $T_J = 25^\circ\text{C}$			360	mV
		$V_I = 24$ to 30 V, $T_J = 25^\circ\text{C}$			180	
$\Delta V_O^{(1)}$	Load regulation	$I_O = 5$ mA to 1.5 A, $T_J = 25^\circ\text{C}$			360	mV
		$I_O = 250$ to 750 mA, $T_J = 25^\circ\text{C}$			180	
I_d	Quiescent current	$T_J = 25^\circ\text{C}$			8	mA
ΔI_d	Quiescent current change	$I_O = 5$ mA to 1 A			0.5	mA
		$V_I = 21$ to 33 V			1	
$\Delta V_O/\Delta T$	Output voltage drift	$I_O = 5$ mA		-1		mV/°C
eN	Output noise voltage	$B = 10$ Hz to 100 kHz, $T_J = 25^\circ\text{C}$		110		$\mu\text{V}/V_O$
SVR	Supply voltage rejection	$V_I = 22$ to 32 V, $f = 120$ Hz	53			dB
V_d	Dropout voltage	$I_O = 1$ A, $T_J = 25^\circ\text{C}$		2		V
R_O	Output resistance	$f = 1$ kHz		22		m Ω
I_{sc}	Short circuit current	$V_I = 35$ V, $T_J = 25^\circ\text{C}$		0.20		A
I_{scp}	Short circuit peak current	$T_J = 25^\circ\text{C}$		2.1		A

1. Load and line regulation are specified at constant junction temperature. Changes in V_O due to heating effects must be taken into account separately. Pulse testing with low duty cycle is used.

Table 22. Electrical characteristics of L7820C (refer to the test circuits, $T_J = 0$ to 150 °C, $V_I = 28$ V, $I_O = 500$ mA, $C_I = 0.33$ μ F, $C_O = 0.1$ μ F unless otherwise specified)

Symbol	Parameter	Test conditions	Min.	Typ.	Max.	Unit
V_O	Output voltage	$T_J = 25^\circ\text{C}$	19.2	20	20.8	V
V_O	Output voltage	$I_O = 5$ mA to 1 A, $P_O \leq 15$ W $V_I = 23$ to 35 V	19	20	21	V
$\Delta V_O^{(1)}$	Line regulation	$V_I = 22.5$ to 35 V, $T_J = 25^\circ\text{C}$			400	mV
		$V_I = 26$ to 32 V, $T_J = 25^\circ\text{C}$			200	
$\Delta V_O^{(1)}$	Load regulation	$I_O = 5$ mA to 1.5 A, $T_J = 25^\circ\text{C}$			400	mV
		$I_O = 250$ to 750 mA, $T_J = 25^\circ\text{C}$			200	
I_d	Quiescent current	$T_J = 25^\circ\text{C}$			8	mA
ΔI_d	Quiescent current change	$I_O = 5$ mA to 1 A			0.5	mA
		$V_I = 23$ to 35 V			1	
$\Delta V_O/\Delta T$	Output voltage drift	$I_O = 5$ mA		-1		mV/°C
eN	Output noise voltage	$B = 10$ Hz to 100 kHz, $T_J = 25^\circ\text{C}$		150		$\mu\text{V}/V_O$
SVR	Supply voltage rejection	$V_I = 24$ to 35 V, $f = 120$ Hz	52			dB
V_d	Dropout voltage	$I_O = 1$ A, $T_J = 25^\circ\text{C}$		2		V
R_O	Output resistance	$f = 1$ kHz		24		m Ω
I_{sc}	Short circuit current	$V_I = 35$ V, $T_J = 25^\circ\text{C}$		0.18		A
I_{scp}	Short circuit peak current	$T_J = 25^\circ\text{C}$		2.1		A

1. Load and line regulation are specified at constant junction temperature. Changes in V_O due to heating effects must be taken into account separately. Pulse testing with low duty cycle is used.

Table 23. Electrical characteristics of L7824C (refer to the test circuits, $T_J = 0$ to 150 °C, $V_I = 33$ V, $I_O = 500$ mA, $C_I = 0.33$ μ F, $C_O = 0.1$ μ F unless otherwise specified)

Symbol	Parameter	Test conditions	Min.	Typ.	Max.	Unit
V_O	Output voltage	$T_J = 25^\circ\text{C}$	23	24	25	V
V_O	Output voltage	$I_O = 5$ mA to 1 A, $P_O \leq 15$ W $V_I = 27$ to 38 V	22.8	24	25.2	V
$\Delta V_O^{(1)}$	Line regulation	$V_I = 27$ to 38 V, $T_J = 25^\circ\text{C}$			480	mV
		$V_I = 30$ to 36 V, $T_J = 25^\circ\text{C}$			240	
$\Delta V_O^{(1)}$	Load regulation	$I_O = 5$ mA to 1.5 A, $T_J = 25^\circ\text{C}$			480	mV
		$I_O = 250$ to 750 mA, $T_J = 25^\circ\text{C}$			240	
I_d	Quiescent current	$T_J = 25^\circ\text{C}$			8	mA
ΔI_d	Quiescent current change	$I_O = 5$ mA to 1 A			0.5	mA
		$V_I = 27$ to 38 V			1	
$\Delta V_O/\Delta T$	Output voltage drift	$I_O = 5$ mA		-1.5		mV/°C
eN	Output noise voltage	$B = 10$ Hz to 100 kHz, $T_J = 25^\circ\text{C}$		170		$\mu\text{V}/V_O$
SVR	Supply voltage rejection	$V_I = 28$ to 38 V, $f = 120$ Hz	50			dB
V_d	Dropout voltage	$I_O = 1$ A, $T_J = 25^\circ\text{C}$		2		V
R_O	Output resistance	$f = 1$ kHz		28		m Ω
I_{sc}	Short circuit current	$V_I = 35$ V, $T_J = 25^\circ\text{C}$		0.15		A
I_{scp}	Short circuit peak current	$T_J = 25^\circ\text{C}$		2.1		A

1. Load and line regulation are specified at constant junction temperature. Changes in V_O due to heating effects must be taken into account separately. Pulse testing with low duty cycle is used.

6 Typical performance

Figure 8. Dropout voltage vs junction temperature

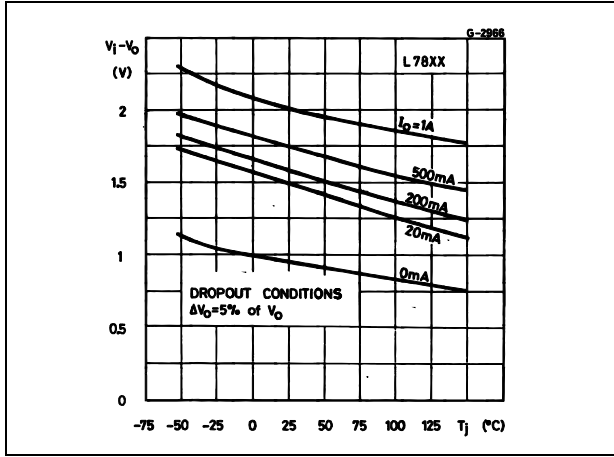

Figure 9. Peak output current vs input/output differential voltage

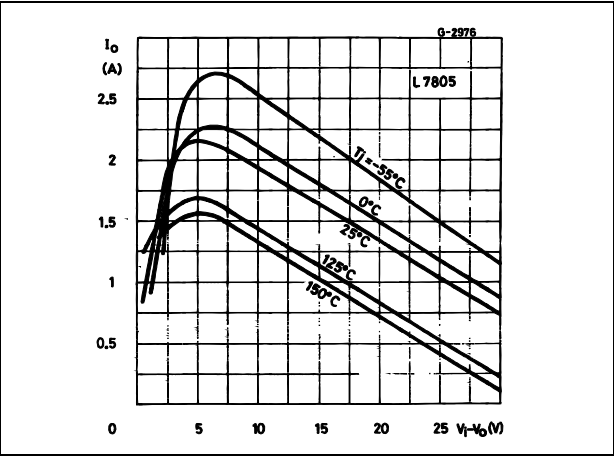

Figure 10. Supply voltage rejection vs frequency

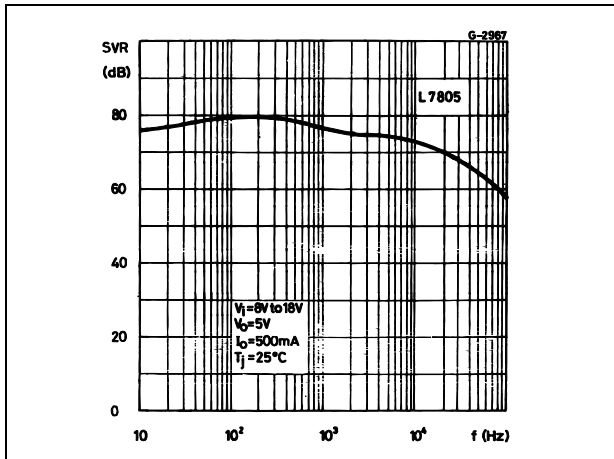

Figure 11. Output voltage vs junction temperature

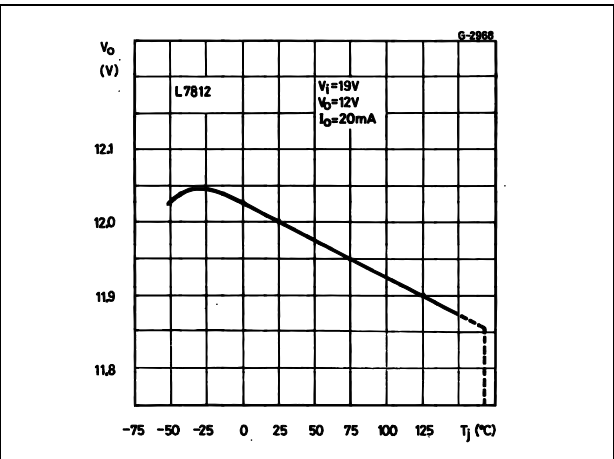

Figure 12. Output impedance vs frequency

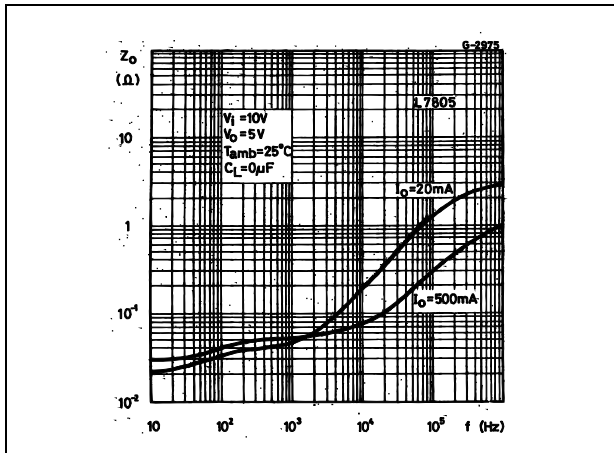

Figure 13. Quiescent current vs junction temp.

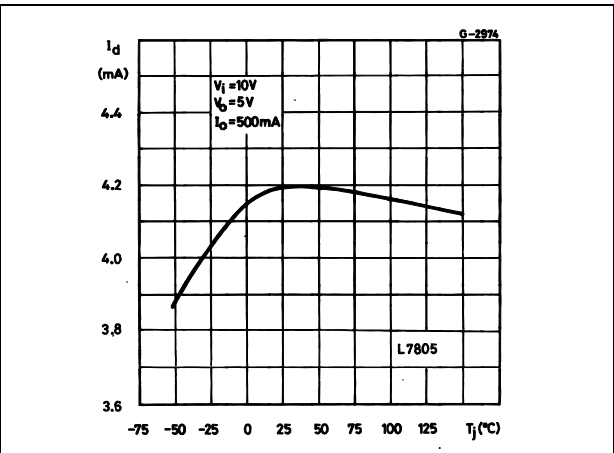

Figure 14. Load transient response

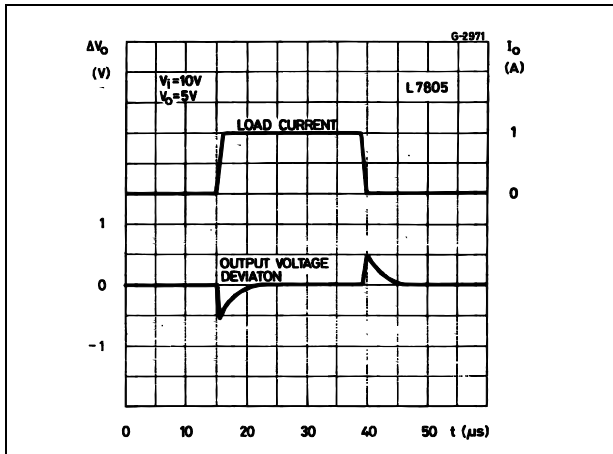

Figure 15. Line transient response

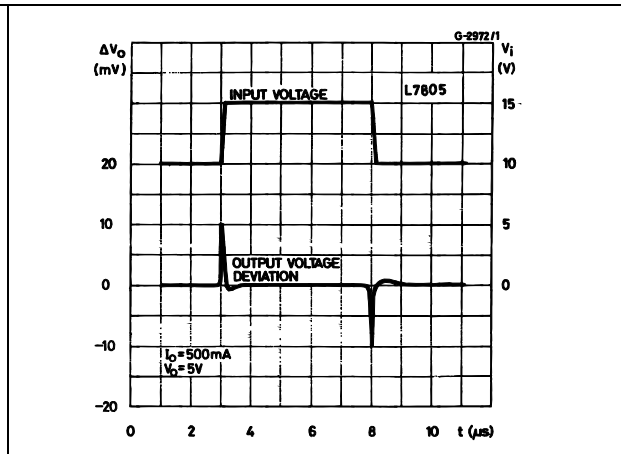

Figure 16. Quiescent current vs input voltage

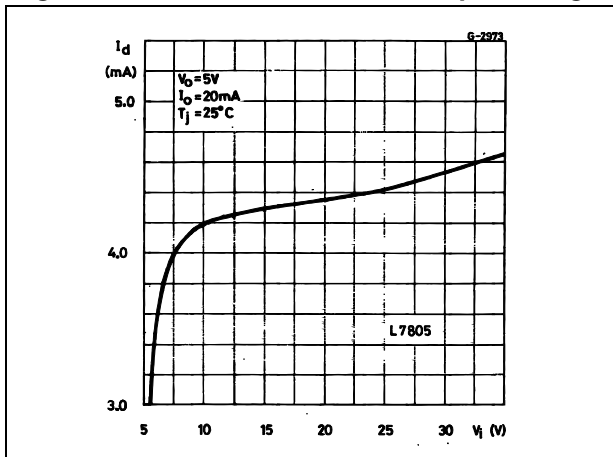
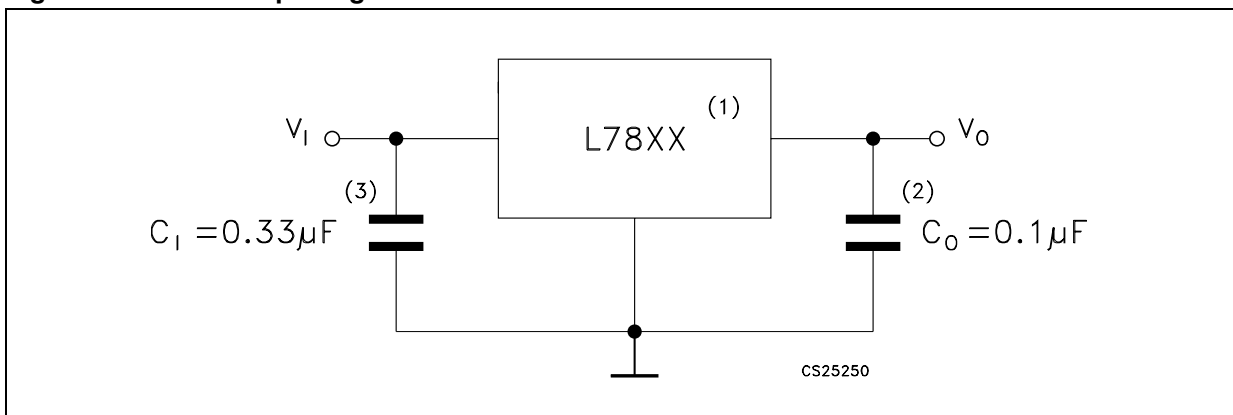

Figure 17. Fixed output regulator



1. To specify an output voltage, substitute voltage value for "XX".
2. Although no output capacitor is need for stability, it does improve transient response.
3. Required if regulator is locate an appreciable distance from power supply filter.

Figure 18. Current regulator

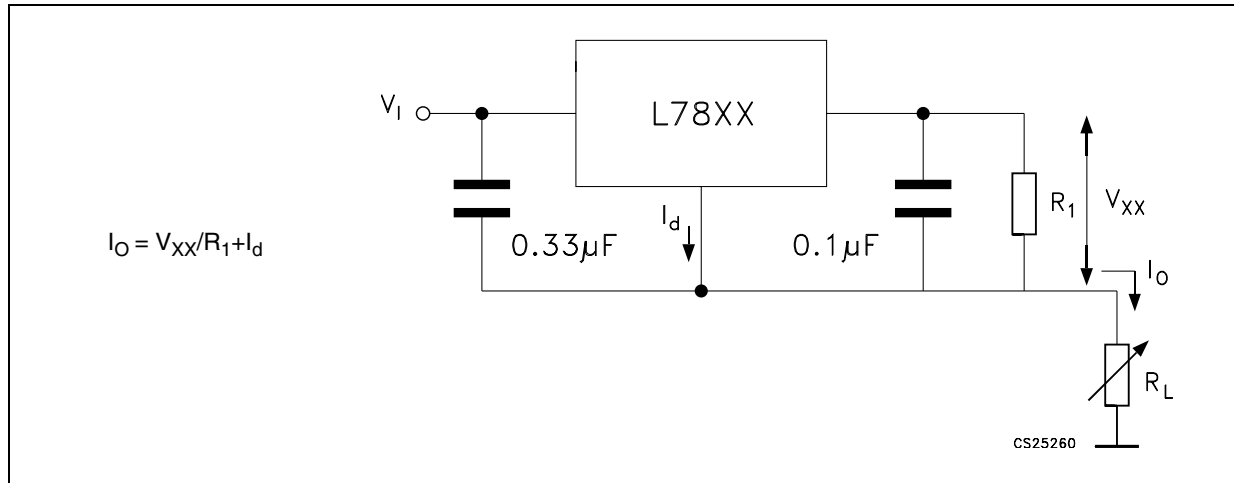

Figure 19. Circuit for increasing output voltage

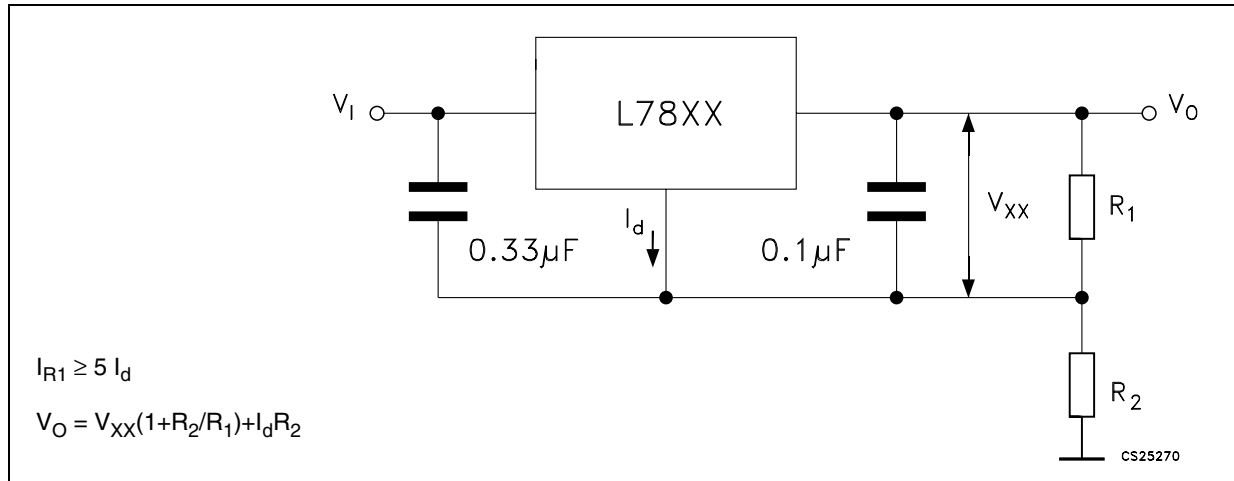

Figure 20. Adjustable output regulator (7 to 30 V)

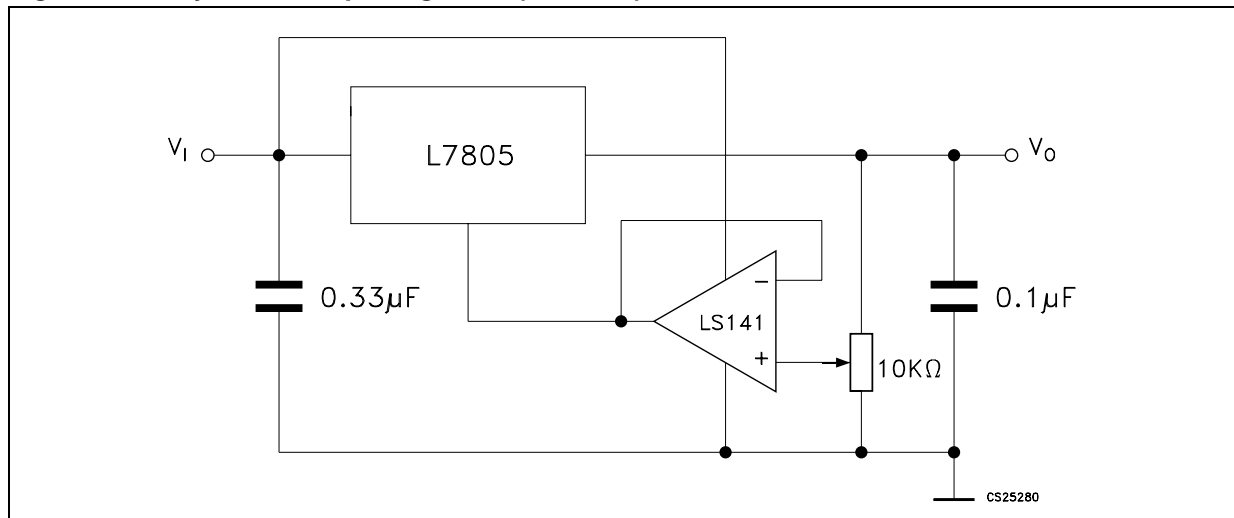

Figure 21. 0.5 to 10 V regulator

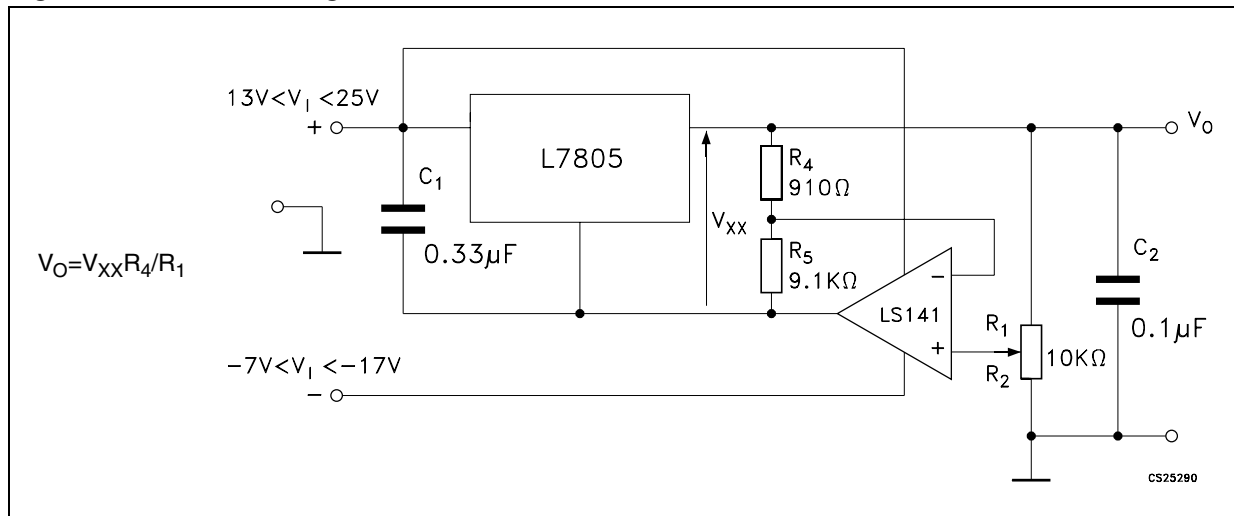

Figure 22. High current voltage regulator

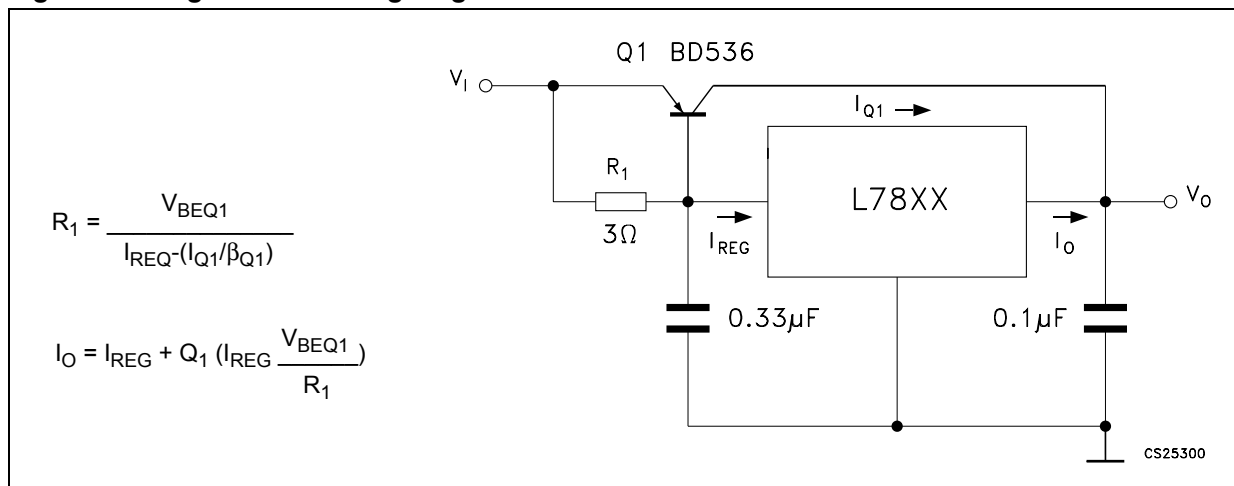

Figure 23. High output current with short circuit protection

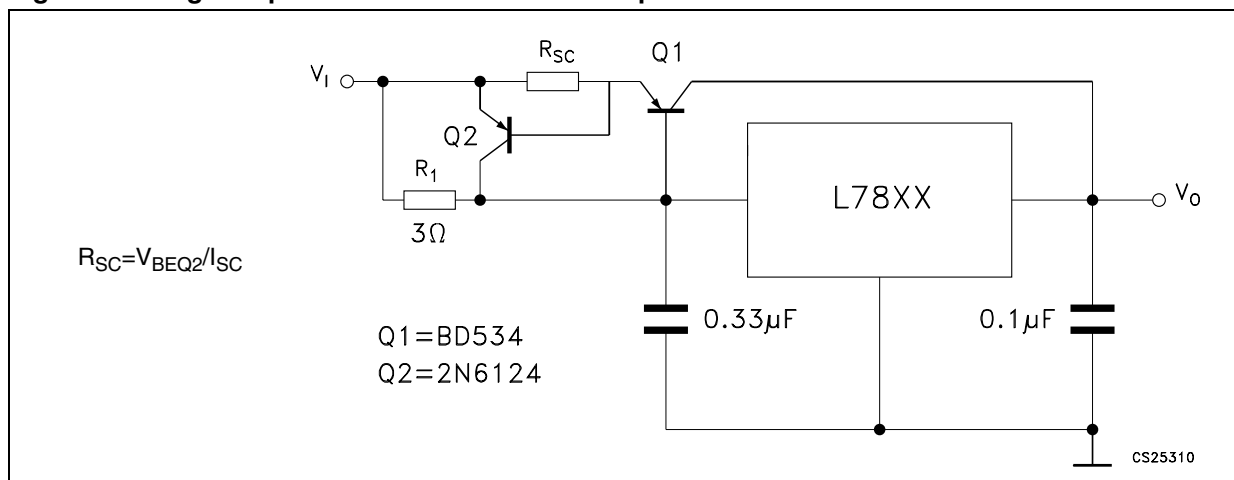

Figure 24. Tracking voltage regulator

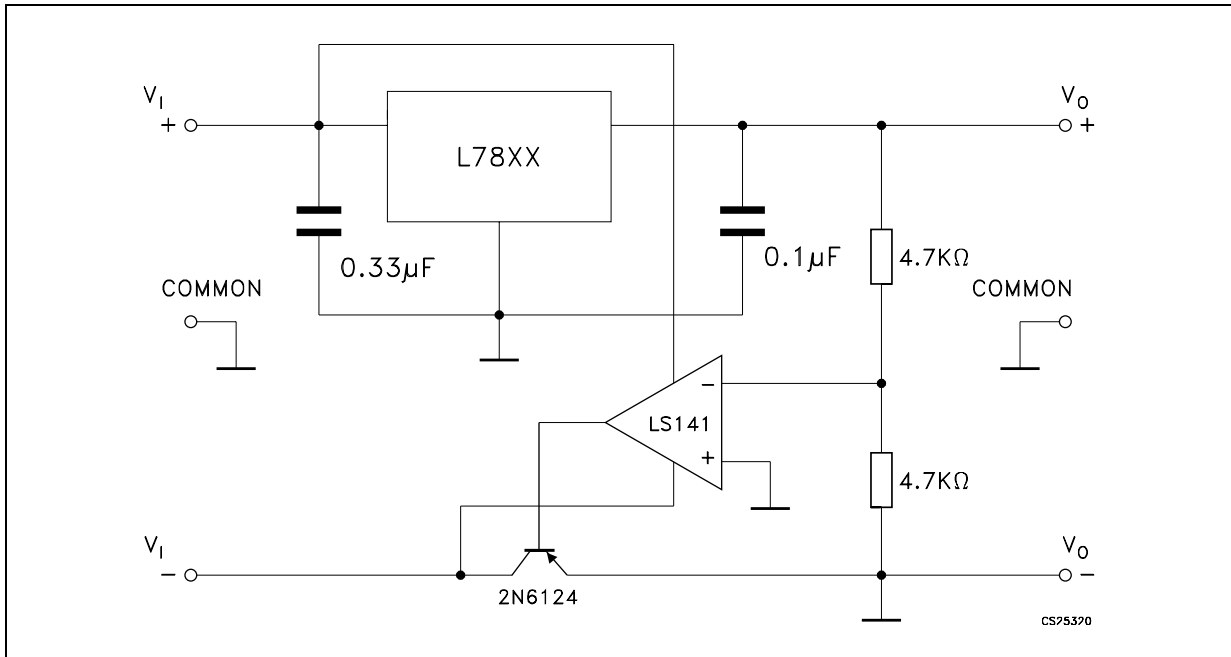
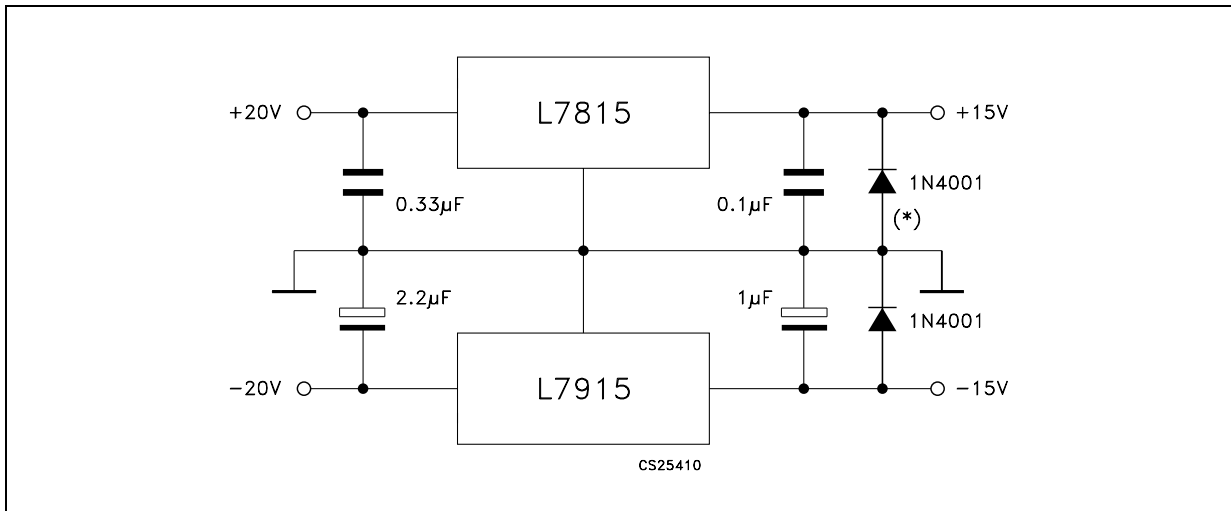

Figure 25. Split power supply ($\pm 15\text{ V} - 1\text{ A}$)



* Against potential latch-up problems.

Figure 26. Negative output voltage circuit

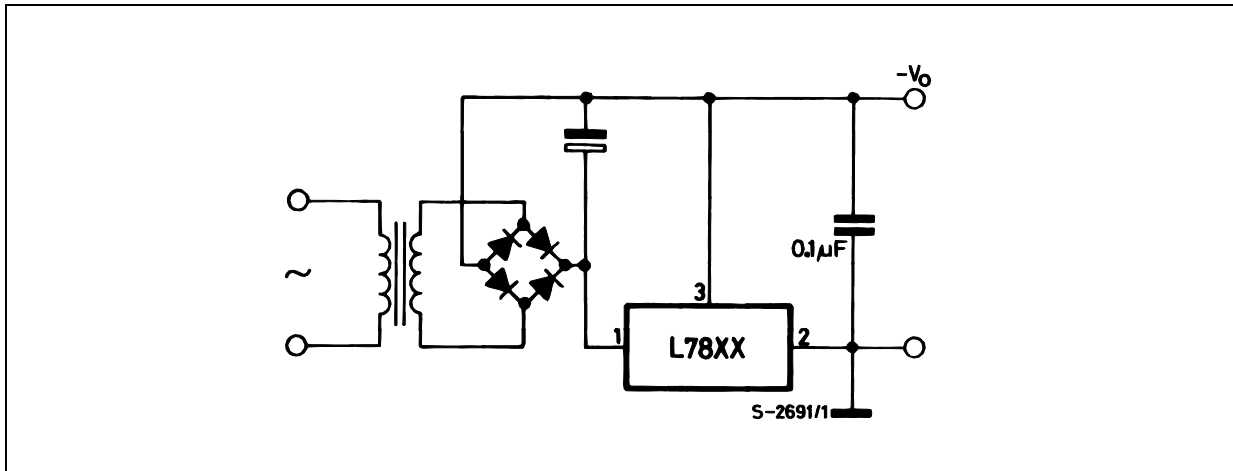

Figure 27. Switching regulator

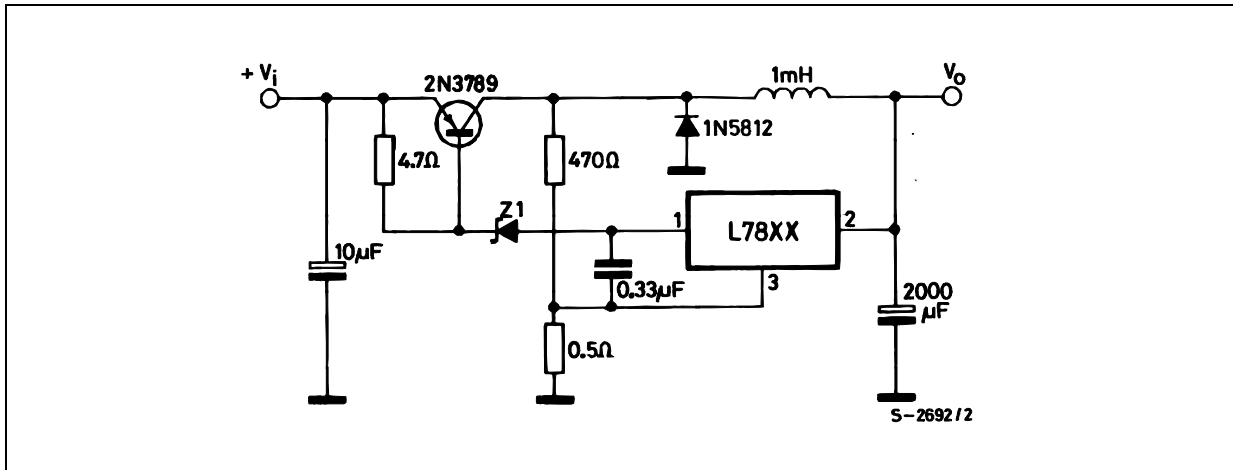

Figure 28. High input voltage circuit

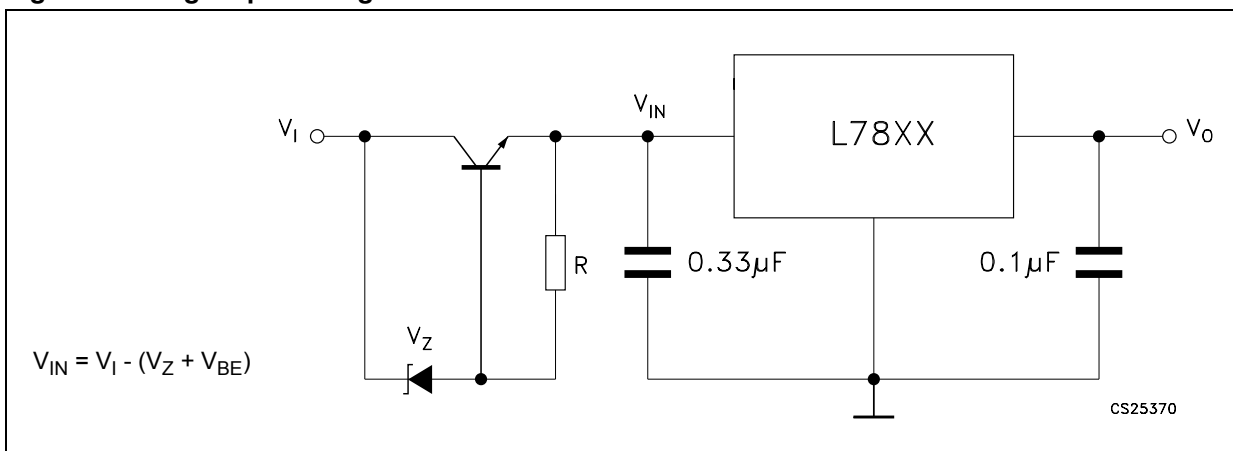

Figure 29. High input voltage circuit

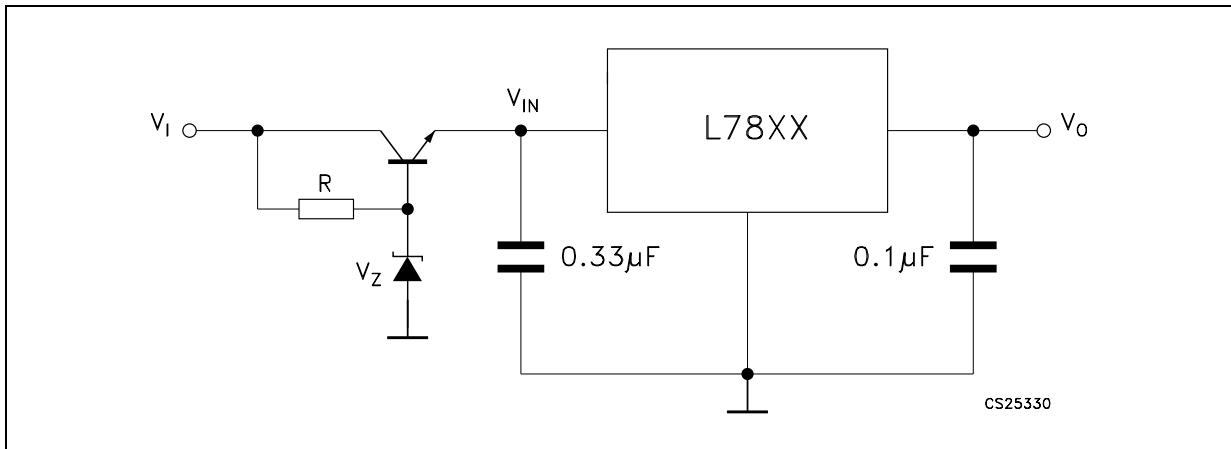

Figure 30. High output voltage regulator

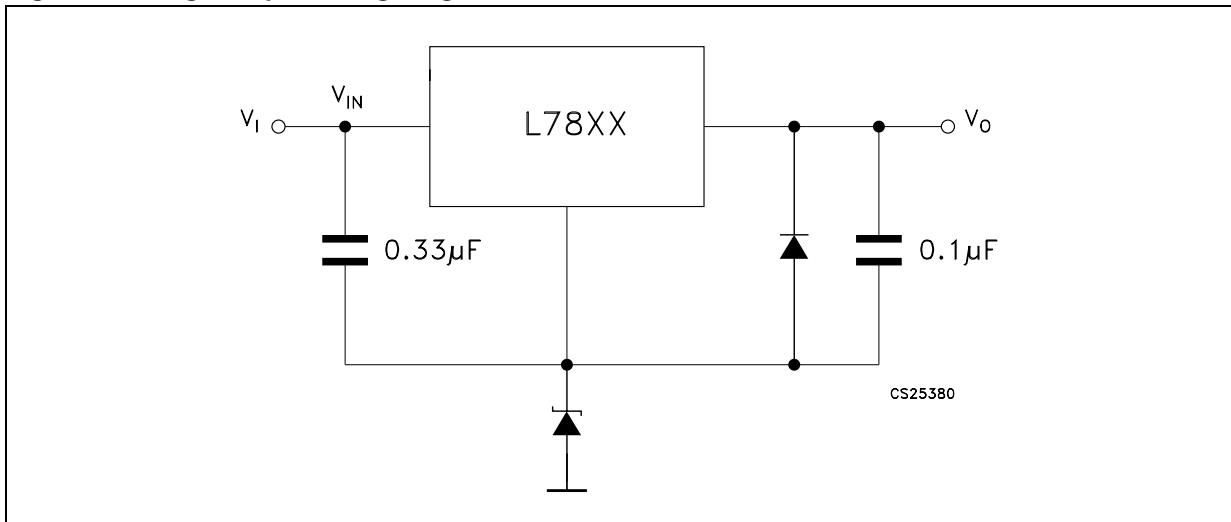

Figure 31. High input and output voltage

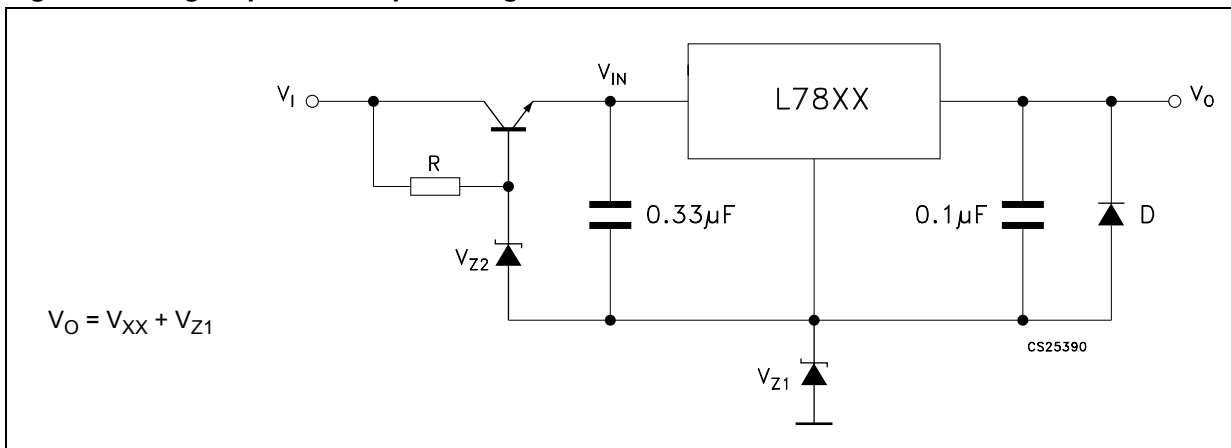

Figure 32. Reducing power dissipation with dropping resistor

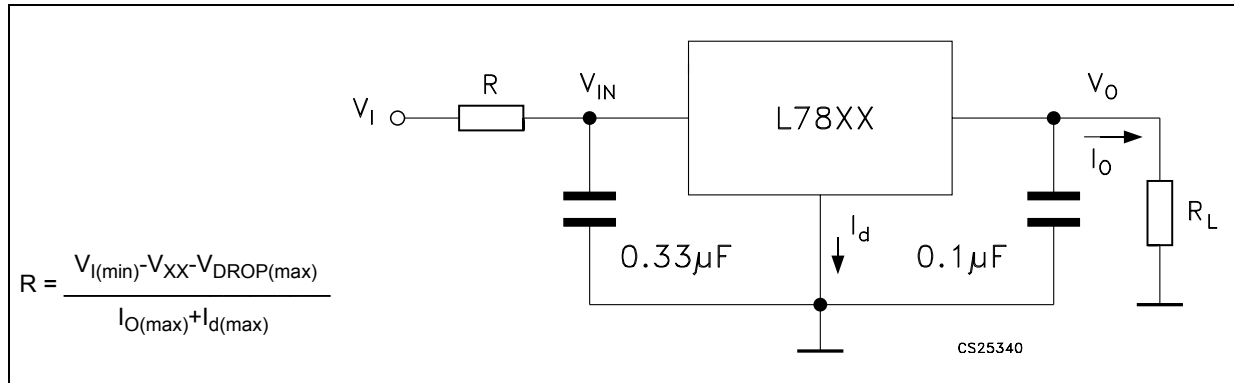

Figure 33. Remote shutdown

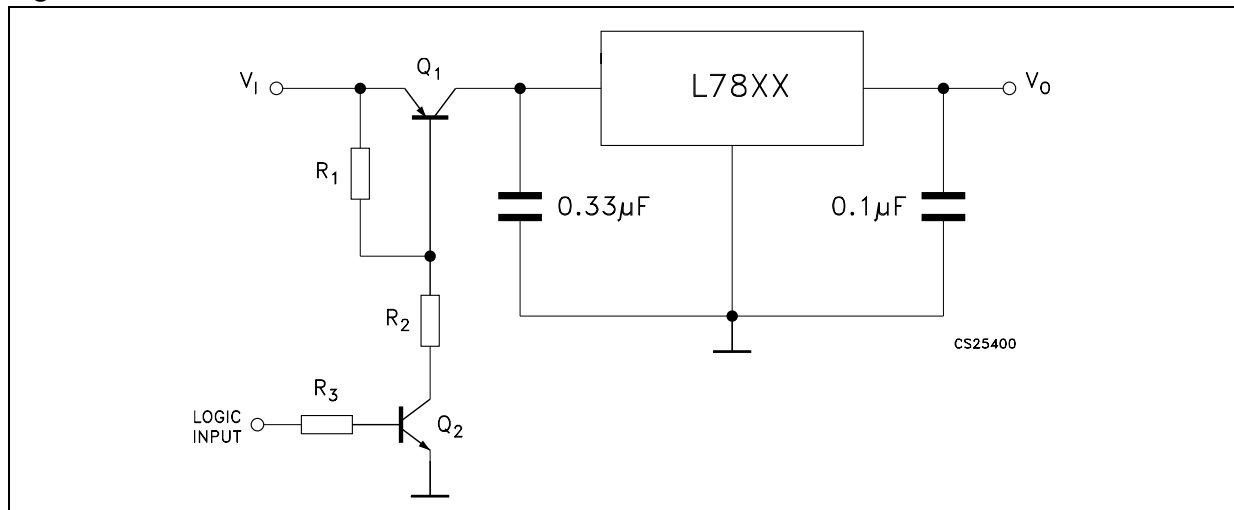
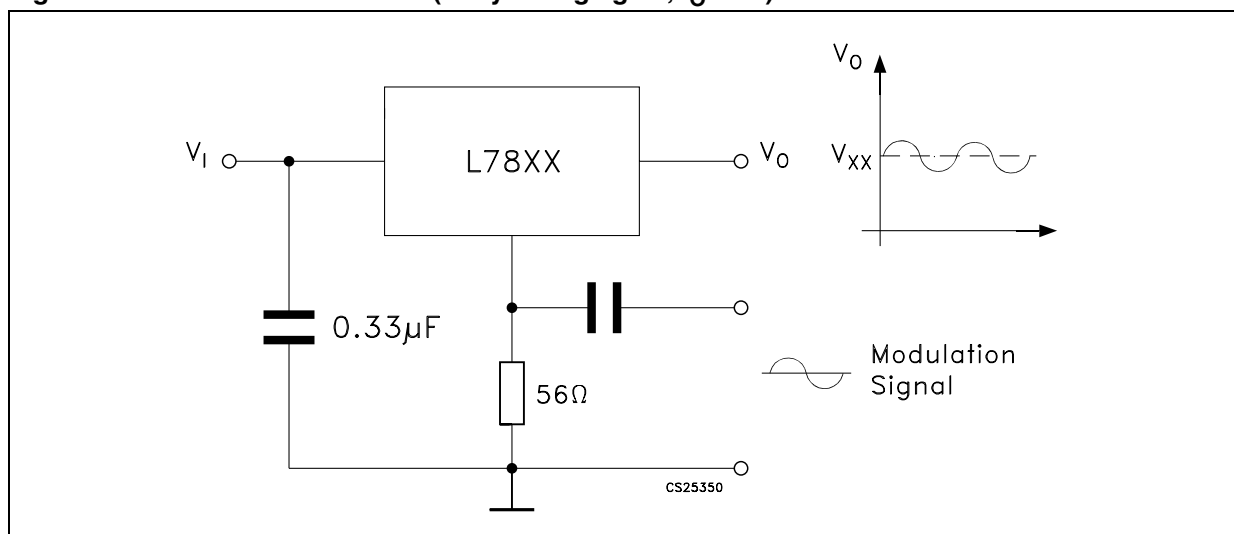
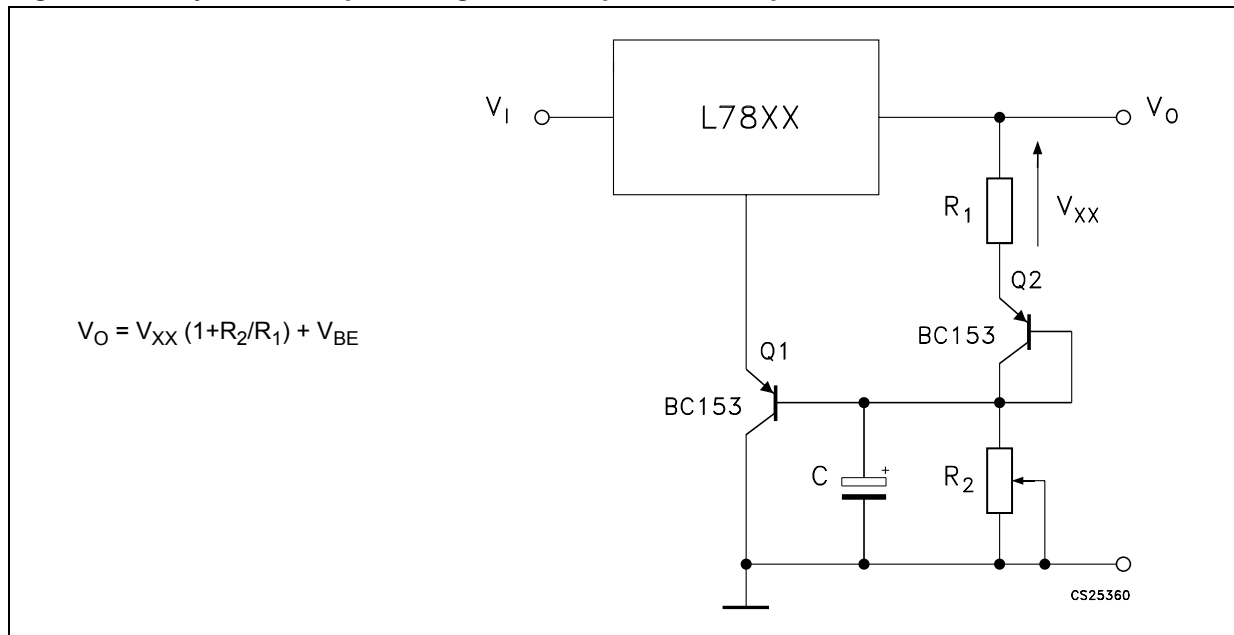

Figure 34. Power AM modulator (unity voltage gain, $I_O \leq 0.5$)



Note: The circuit performs well up to 100 kHz.

Figure 35. Adjustable output voltage with temperature compensation



Note: Q_2 is connected as a diode in order to compensate the variation of the $Q_1 V_{BE}$ with the temperature. C allows a slow rise time of the V_o .

Figure 36. Light controllers ($V_{Omin} = V_{XX} + V_{BE}$)

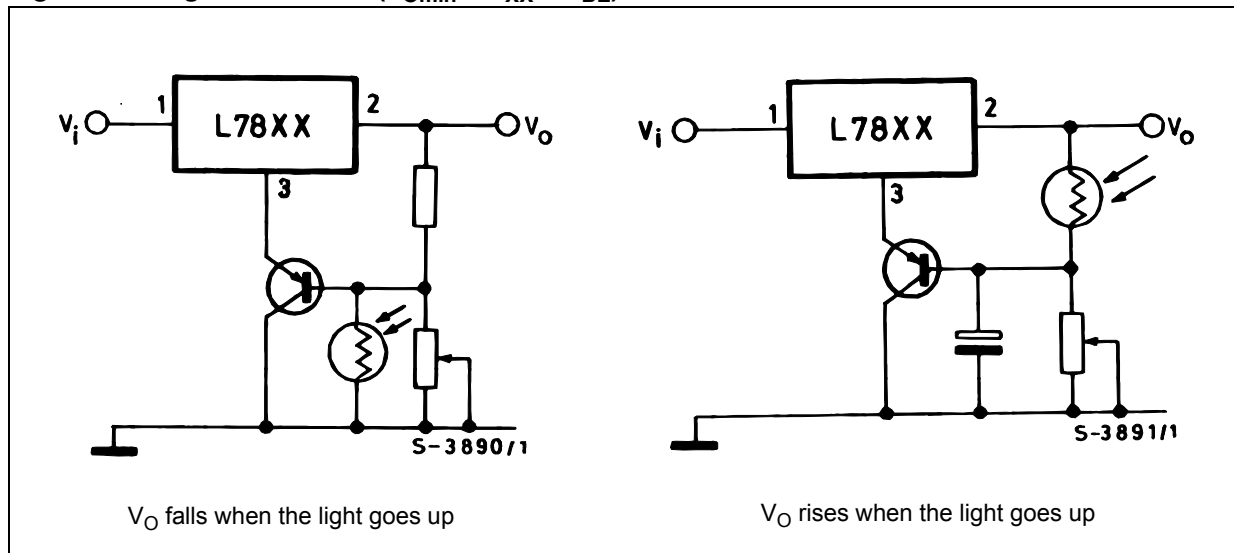
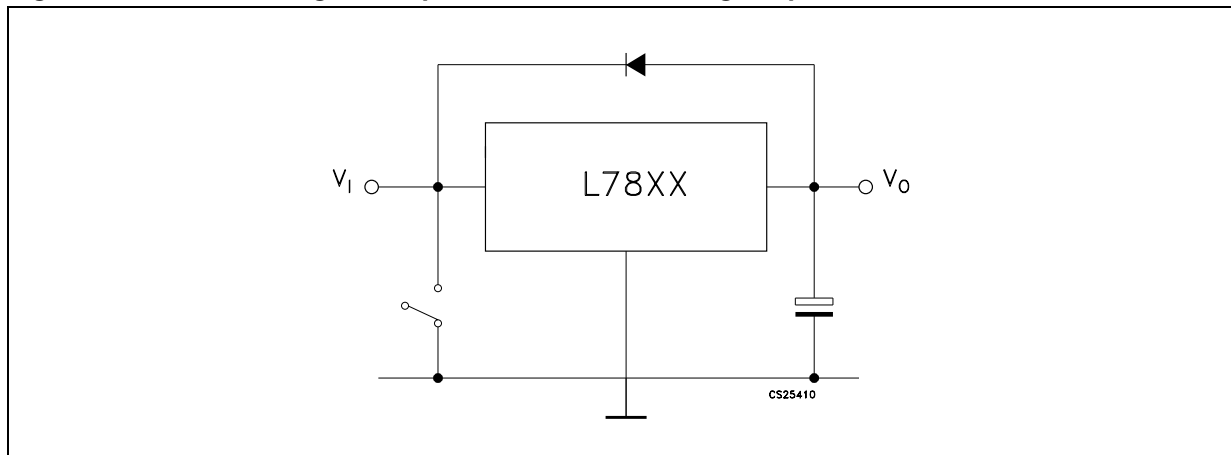

Figure 37. Protection against input short-circuit with high capacitance loads

1. Application with high capacitance loads and an output voltage greater than 6 volts need an external diode (see [Figure 32 on page 36](#)) to protect the device against input short circuit. In this case the input voltage falls rapidly while the output voltage decrease slowly. The capacitance discharges by means of the Base-Emitter junction of the series pass transistor in the regulator. If the energy is sufficiently high, the transistor may be destroyed. The external diode by-passes the current from the IC to ground.

7 Package mechanical data

In order to meet environmental requirements, ST offers these devices in ECOPACK[®] packages. These packages have a lead-free second level interconnect. The category of second Level Interconnect is marked on the package and on the inner box label, in compliance with JEDEC Standard JESD97. The maximum ratings related to soldering conditions are also marked on the inner box label. ECOPACK is an ST trademark. ECOPACK specifications are available at: www.st.com.

Figure 38. Drawing dimension TO-220 (type SMIC-subcon.)

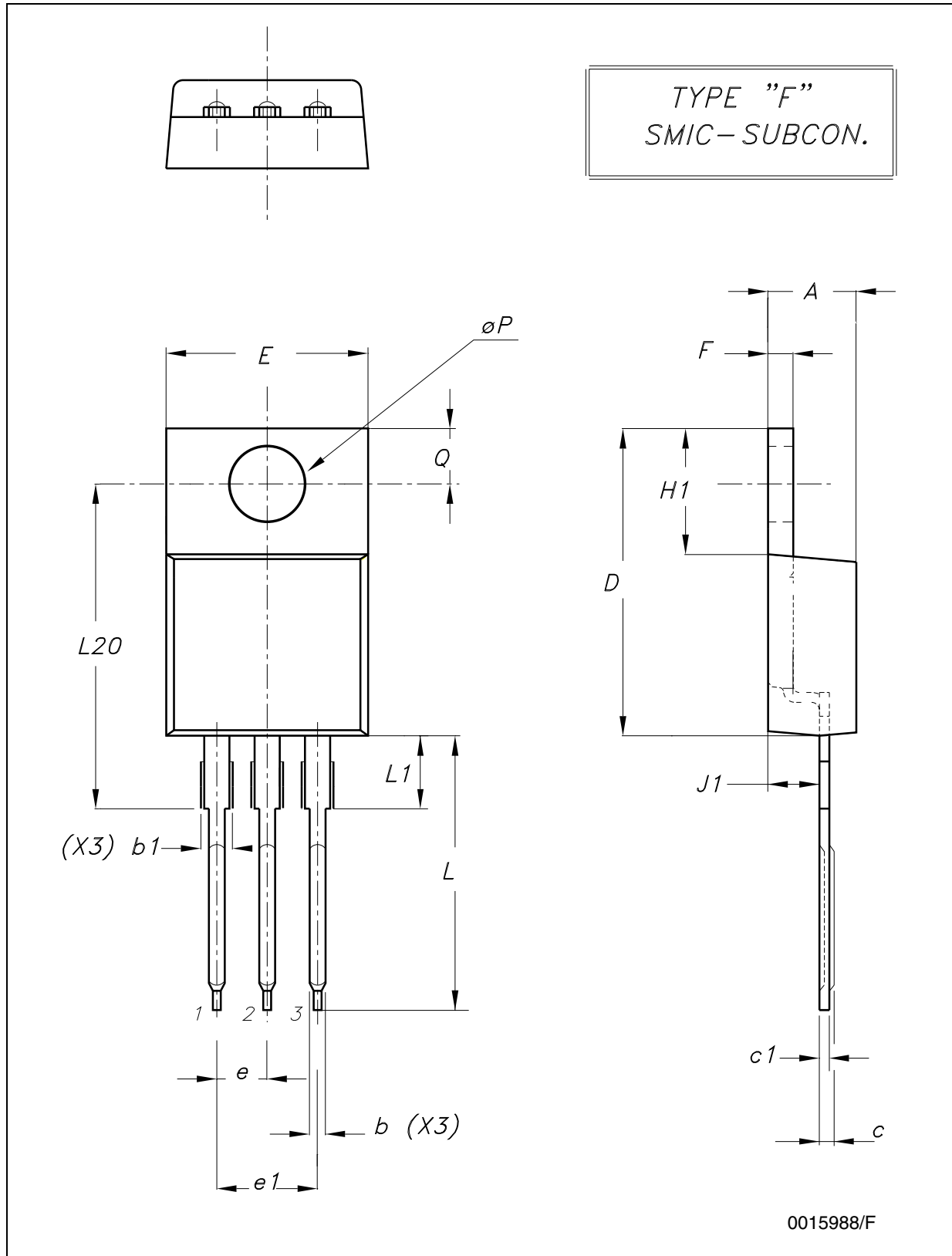

Figure 39. Drawing dimension TO-220 (type STD-ST)

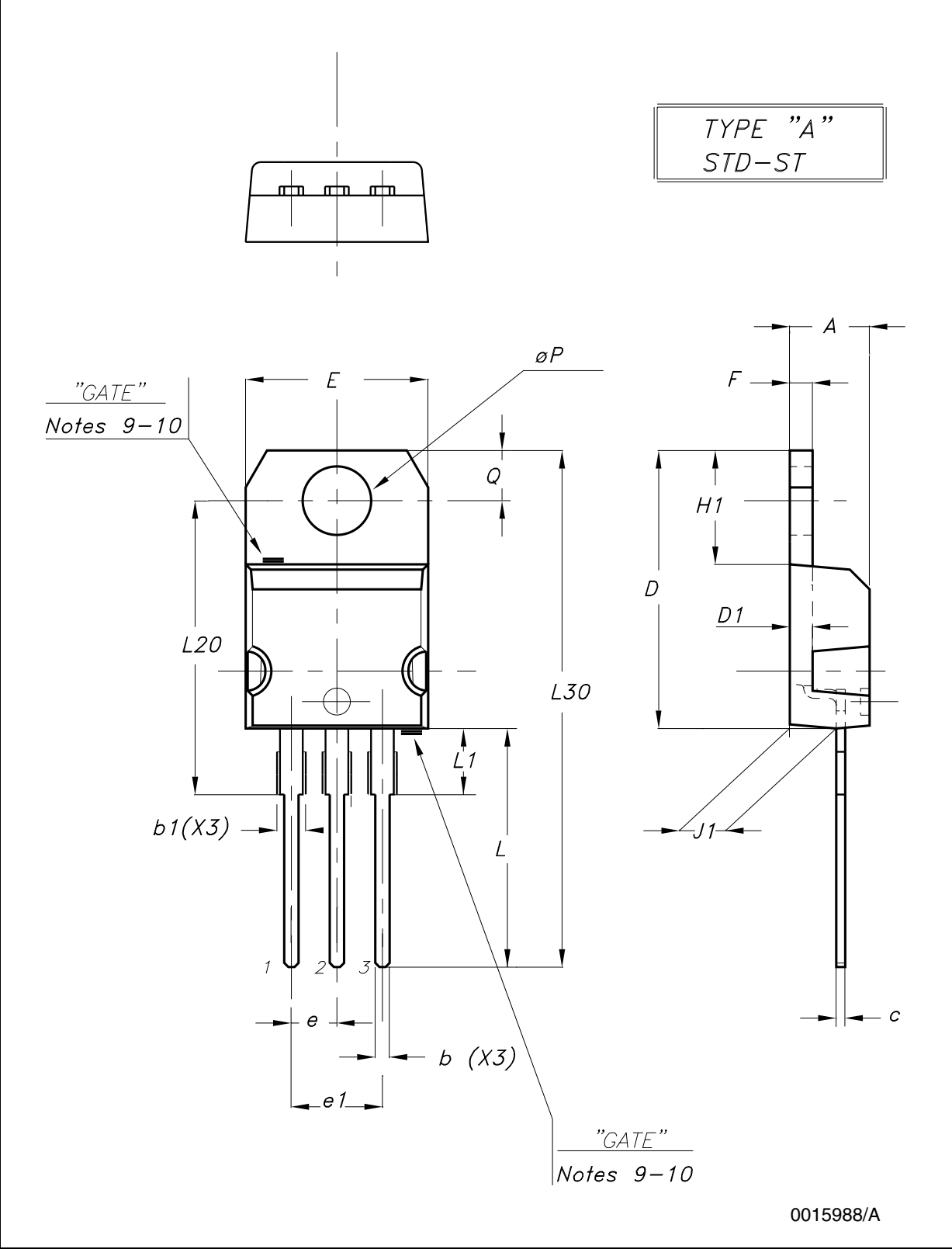

Table 24. TO-220 mechanical data

Dim.	Type STD-ST			Type SMIC-Subcon.		
	mm.			mm.		
	Min.	Typ.	Max.	Min.	Typ.	Max.
A	4.40		4.60	4.47	4.57	4.67
A1	0.61		0.88	0.80	0.81	0.86
b1	1.14		1.70	1.15		1.44
c	0.49		0.70		0.56	
c1					0.38	
D	15.25		15.75	15.07	15.24	15.45
D1		1.27				
E	10.00		10.40	10	10.15	10.30
e	2.40		2.70	2.29	2.54	2.79
e1	4.95		5.15	4.83	5.08	5.33
F	1.23		1.32		1.27	
H1	6.20		6.60		6.24	
J1	2.40		2.72	2.04	2.67	2.92
L	13.00		14.00	13.35	13.50	13.65
L1	3.50		3.93		3.90	
L20		16.40		16.25	16.40	16.55
L30		28.90			28.74	
ØP	3.75		3.85		3.83	
Q	2.65		2.95	2.72	2.74	2.80

Note: In spite of some difference in tolerances, the packages are compatible.

Figure 40. Drawing dimension TO-220FP

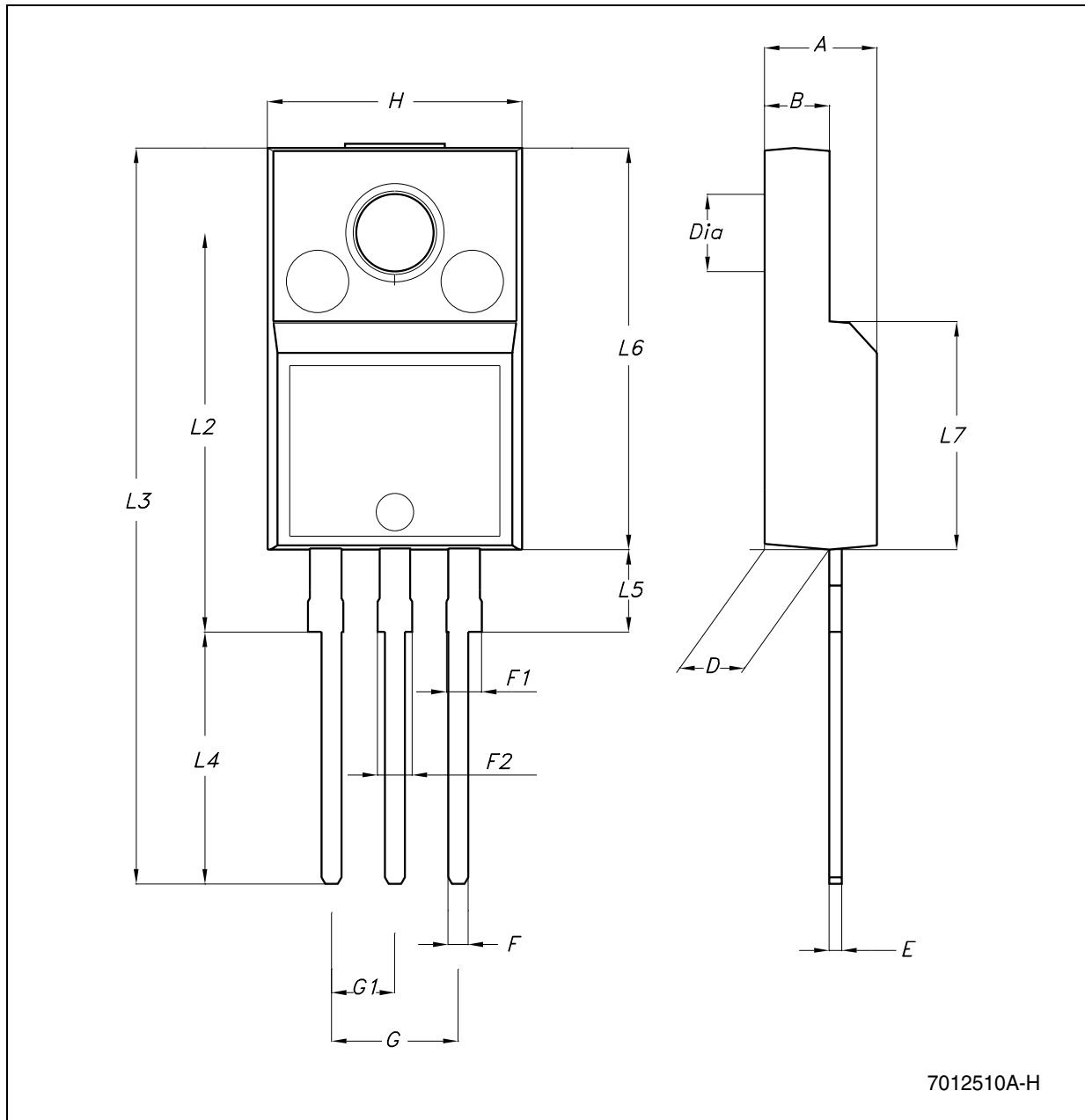

Table 25. TO-220FP mechanical data

Dim.	mm.			inch.		
	Min.	Typ.	Max.	Min.	Typ.	Max.
A	4.40		4.60	0.173		0.181
B	2.5		2.7	0.098		0.106
D	2.5		2.75	0.098		0.108
E	0.45		0.70	0.017		0.027
F	0.75		1	0.030		0.039
F1	1.15		1.50	0.045		0.059
F2	1.15		1.50	0.045		0.059
G	4.95		5.2	0.194		0.204
G1	2.4		2.7	0.094		0.106
H	10.0		10.40	0.393		0.409
L2		16			0.630	
L3	28.6		30.6	1.126		1.204
L4	9.8		10.6	0.385		0.417
L5	2.9		3.6	0.114		0.142
L6	15.9		16.4	0.626		0.645
L7	9		9.3	0.354		0.366
DIA.	3		3.2	0.118		0.126

Figure 41. Drawing dimension TO-3

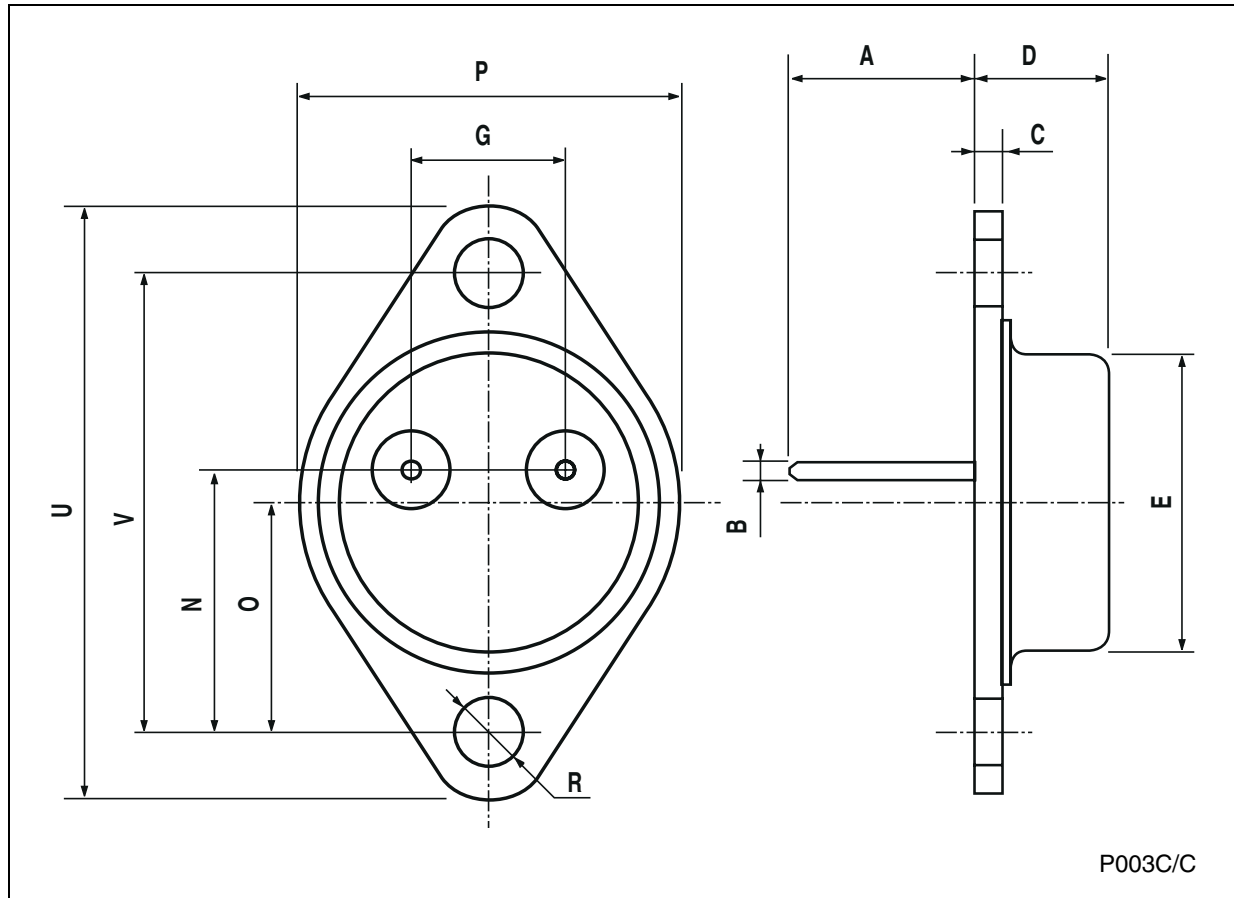
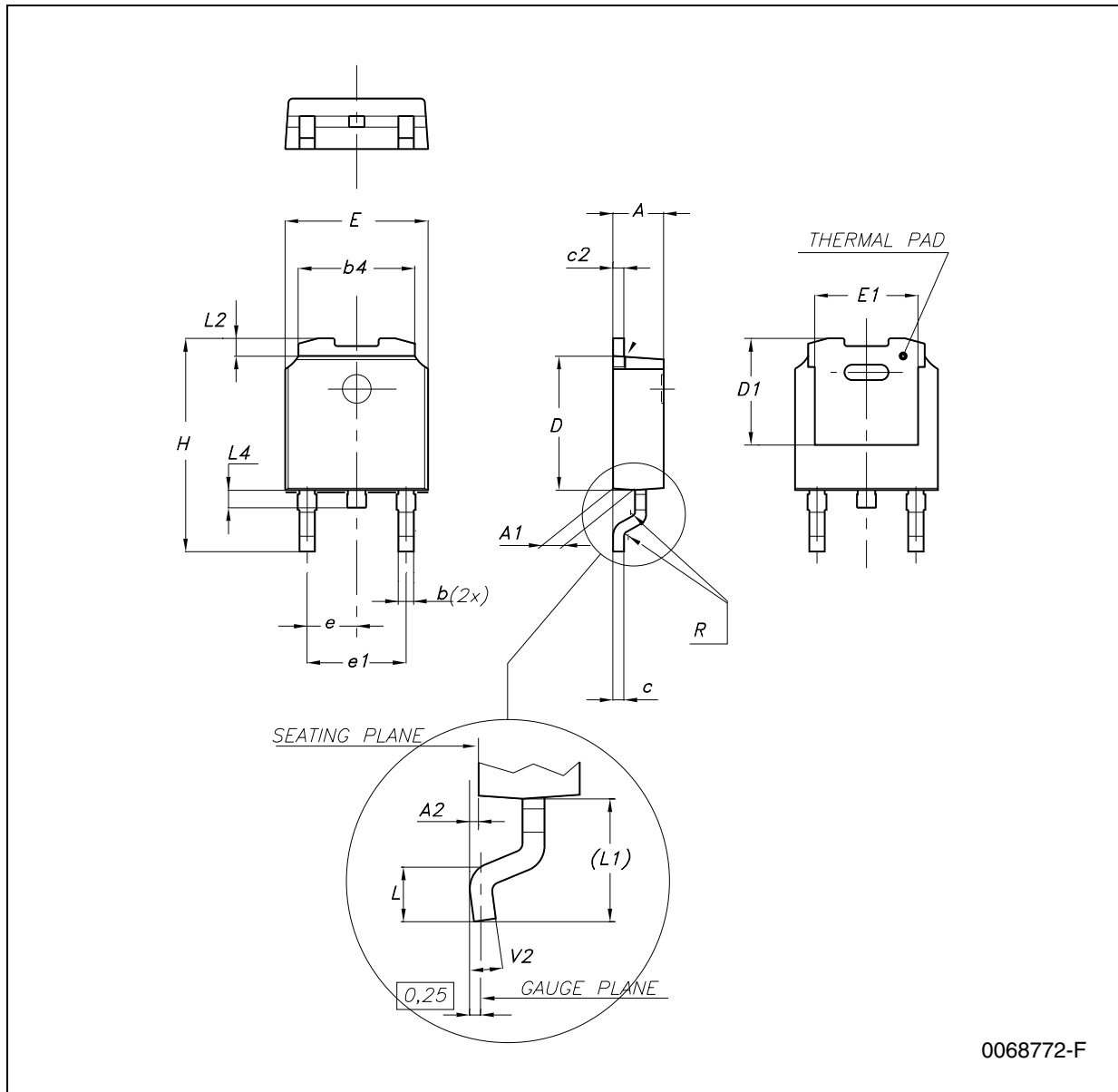

Table 26. TO-3 mechanical data

Dim.	mm.			inch.		
	Min.	Typ.	Max.	Min.	Typ.	Max.
A		11.85			0.466	
B	0.96	1.05	1.10	0.037	0.041	0.043
C			1.70			0.066
D			8.7			0.342
E			20.0			0.787
G		10.9			0.429	
N		16.9			0.665	
P			26.2			1.031
R	3.88		4.09	0.152		0.161
U			39.5			1.555
V		30.10			1.185	

Figure 42. Drawing dimension DPAK



0068772-F

Table 27. DPAK mechanical data

Dim.	mm.			inch.		
	Min.	Typ.	Max.	Min.	Typ.	Max.
A	2.2		2.4	0.086		0.094
A1	0.9		1.1	0.035		0.043
A2	0.03		0.23	0.001		0.009
B	0.64		0.9	0.025		0.035
b4	5.2		5.4	0.204		0.212
C	0.45		0.6	0.017		0.023
C2	0.48		0.6	0.019		0.023
D	6		6.2	0.236		0.244
D1		5.1			0.200	
E	6.4		6.6	0.252		0.260
E1		4.7			0.185	
e		2.28			0.090	
e1	4.4		4.6	0.173		0.181
H	9.35		10.1	0.368		0.397
L	1			0.039		
(L1)		2.8			0.110	
L2		0.8			0.031	
L4	0.6		1	0.023		0.039
R		0.2			0.008	
V2	0°		8°	0°		8°

Figure 43. Drawing dimension tape and reel for DPAK

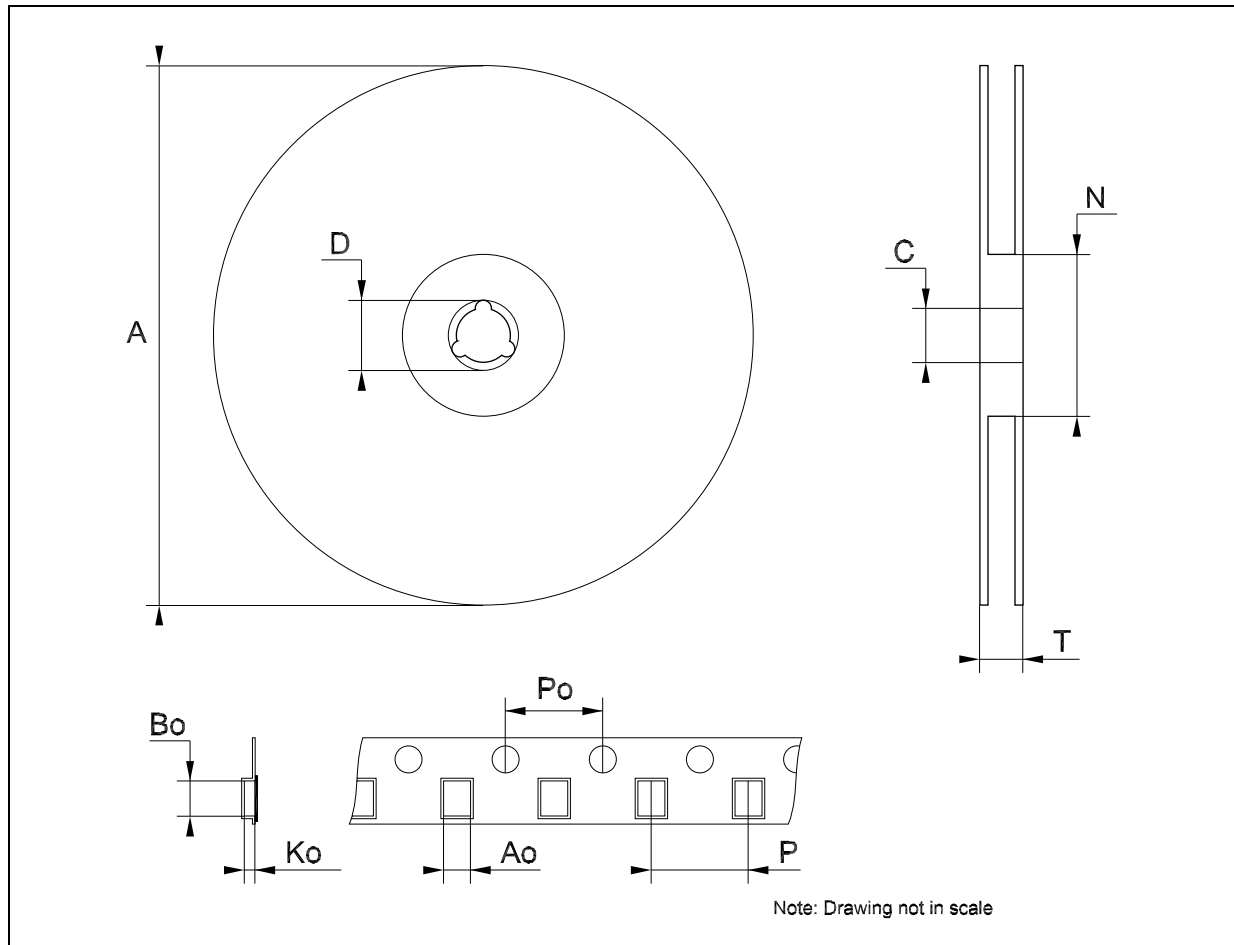

Table 28. Tape and reel DPAK mechanical data

Dim.	mm.			inch.		
	Min.	Typ.	Max.	Min.	Typ.	Max.
A			330			12.992
C	12.8	13.0	13.2	0.504	0.512	0.519
D	20.2			0.795		
N	60			2.362		
T			22.4			0.882
Ao	6.80	6.90	7.00	0.268	0.272	0.276
Bo	10.40	10.50	10.60	0.409	0.413	0.417
Ko	2.55	2.65	2.75	0.100	0.104	0.105
Po	3.9	4.0	4.1	0.153	0.157	0.161
P	7.9	8.0	8.1	0.311	0.315	0.319

Figure 44. Drawing dimension D²PAK (type STD-ST)

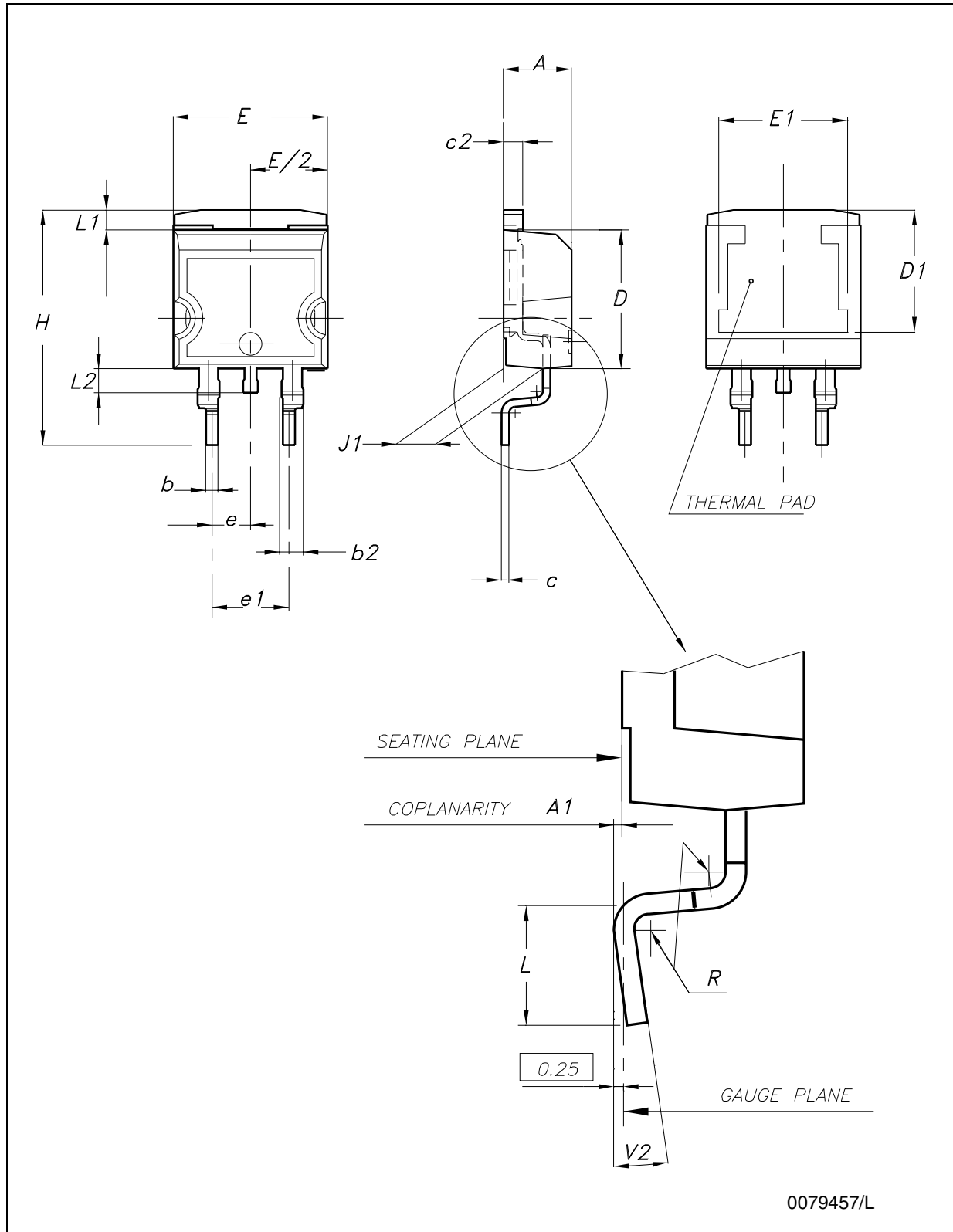

Figure 45. Drawing dimension D²PAK (type WOOSEOK-Subcon.)

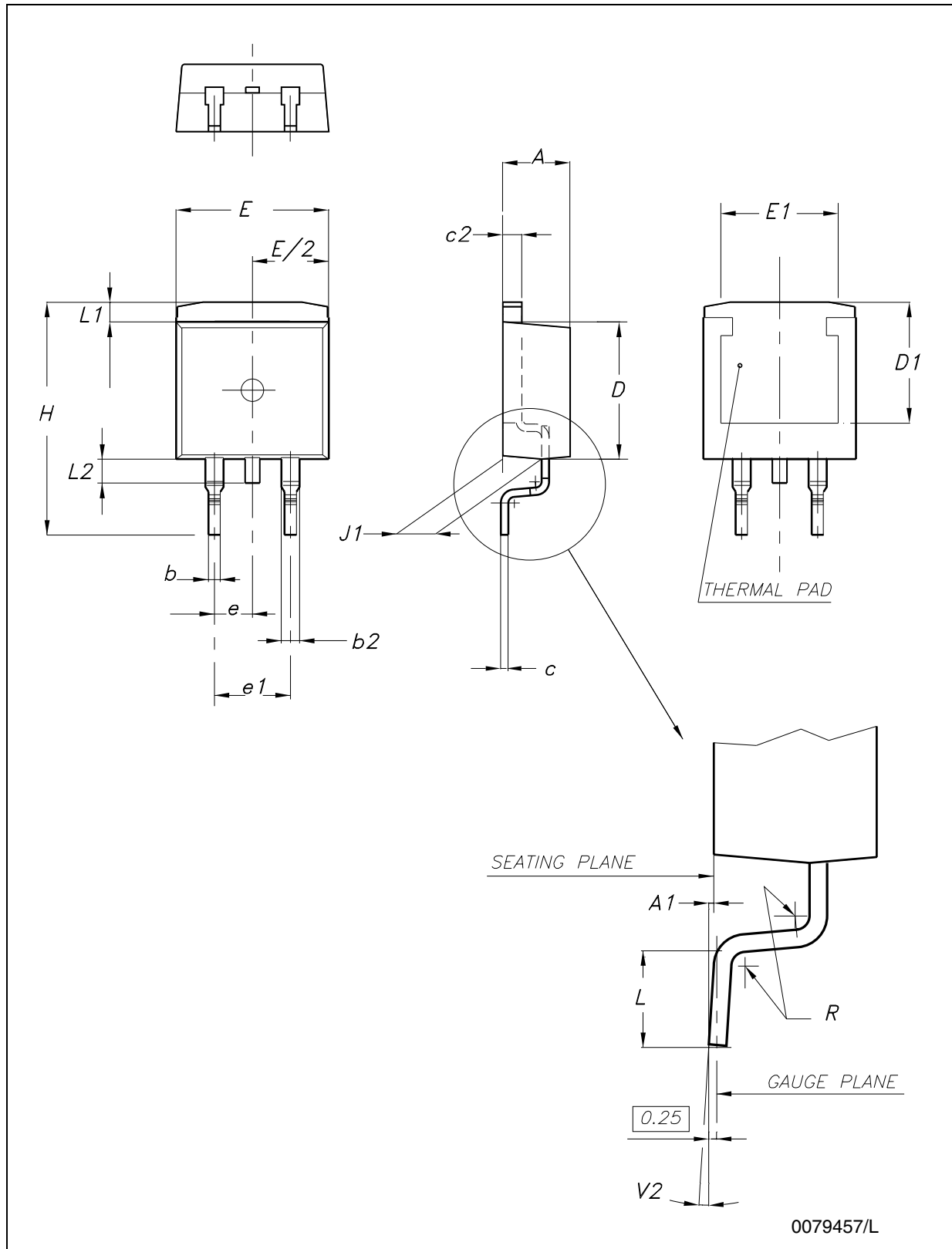

Table 29. D²PAK mechanical data

Dim.	TYPE STD-ST			TYPE WOOSEOK-Subcon.		
	mm.			mm.		
	Min.	Typ.	Max.	Min.	Typ.	Max.
A	4.40		4.60	4.30		4.70
A1	0.03		0.23	0		0.20
b	0.70		0.93	0.70		0.90
b2	1.14		1.70	1.17		1.37
c	0.45		0.60	0.45	0.50	0.60
c2	1.23		1.36	1.25	1.30	1.40
D	8.95		9.35	9	9.20	9.40
D1	7.50			7.50		
E	10		10.40	9.80		10.20
E1	8.50			7.50		
e		2.54			2.54	
e1	4.88		5.28		5.08	
H	15		15.85	15	15.30	15.60
J1	2.49		2.69	2.20		2.60
L	2.29		2.79	1.79		2.79
L1	1.27		1.40	1		1.40
L2	1.30		1.75	1.20		1.60
R		0.4			0.30	
V2	0°		8°	0°		3°

Note: The D²PAK package coming from the subcontractor Wooseok is fully compatible with the ST's package suggested footprint.

Figure 46. D²PAK footprint recommended data

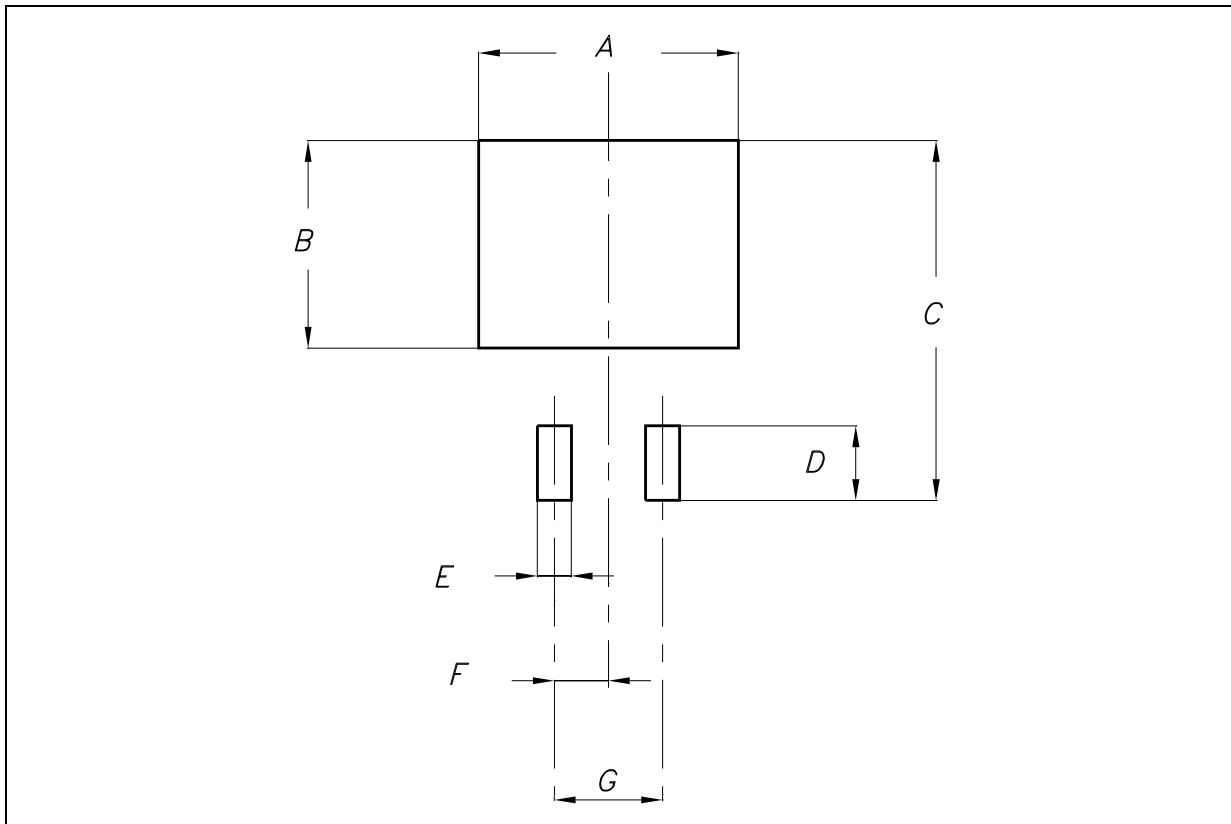

Table 30. D²PAK footprint data

Dim.	Values	
	mm.	inch.
A	12.20	0.480
B	9.75	0.384
C	16.90	0.665
D	3.50	0.138
E	1.60	0.063
F	2.54	0.100
G	5.08	0.200

Table 31. Tape and reel D²PAK mechanical data

Dim.	mm.			inch.		
	Min.	Typ.	Max.	Min.	Typ.	Max.
A			180			7.086
C	12.8	13.0	13.2	0.504	0.512	0.519
D	20.2			0.795		
N	60			2.362		
T			14.4			0.567
Ao	10.50	10.6	10.70	0.413	0.417	0.421
Bo	15.70	15.80	15.90	0.618	0.622	0.626
Ko	4.80	4.90	5.00	0.189	0.193	0.197
Po	3.9	4.0	4.1	0.153	0.157	0.161
P	11.9	12.0	12.1	0.468	0.472	0.476

Figure 47. Drawing dimension tape and reel for D²PAK

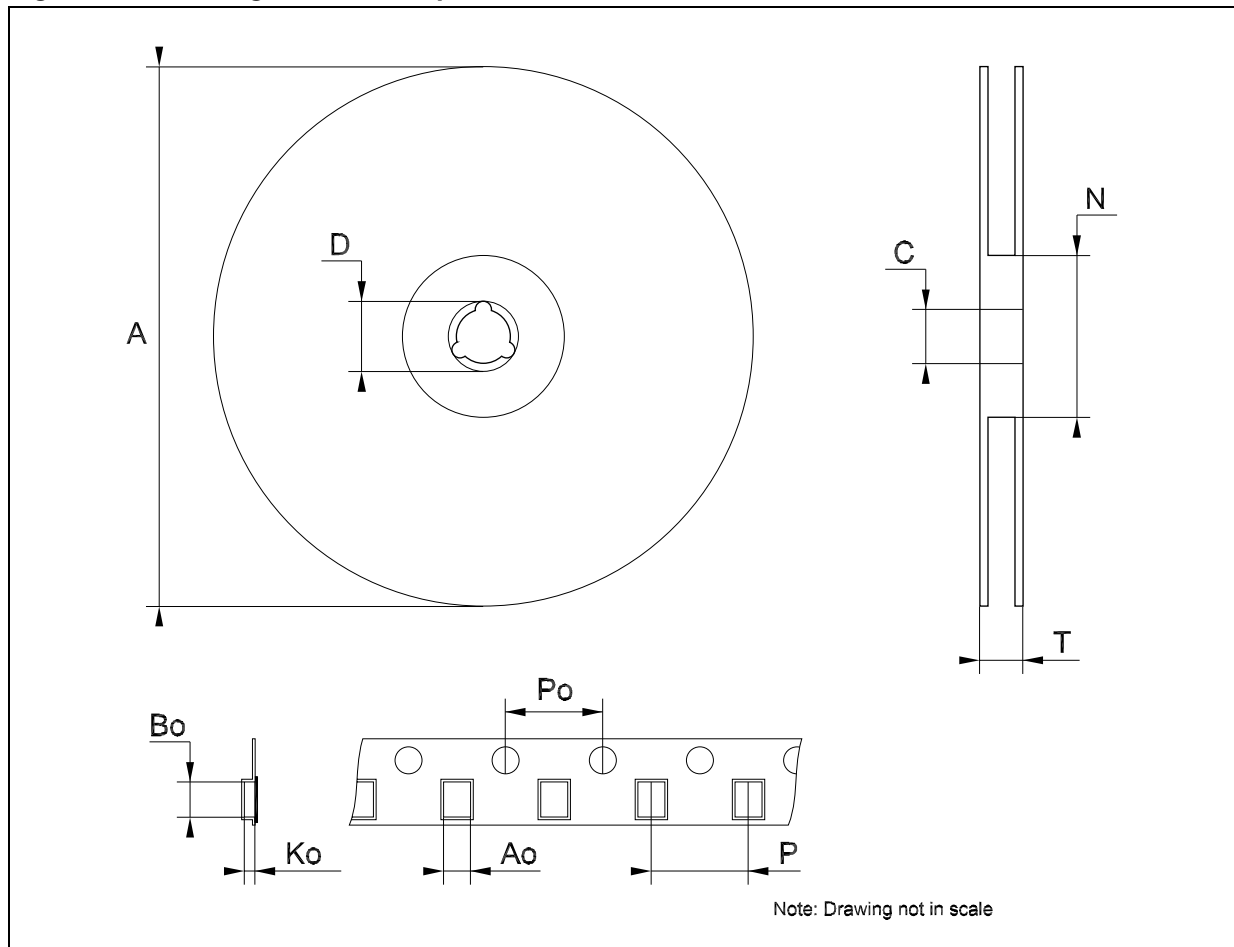

8 Order codes

Table 32. Order codes

Part numbers	Order codes				
	TO-220	DPAK	D ² PAK	TO-220FP	TO-3
L7805					L7805T
L7805C	L7805CV	L7805CDT-TR	L7805CD2T-TR	L7805CP	L7805CT
L7806C	L7806CV		L7806CD2T-TR		L7806CT
L7808C	L7808CV		L7808CD2T-TR	L7808CP	
L7885C	L7885CV		L7885CD2T-TR ⁽¹⁾	L7885CP ⁽¹⁾	L7885CT ⁽¹⁾
L7809C	L7809CV		L7809CD2T-TR	L7809CP	
L7812C	L7812CV		L7812CD2T-TR	L7812CP	L7812CT
L7815C	L7815CV		L7815CD2T-TR	L7815CP	L7815CT
L7818C	L7818CV		L7818CD2T-TR ⁽¹⁾		L7818CT
L7824C	L7824CV		L7824CD2T-TR	L7824CP	L7824CT

1. Available on request.

9 Revision history

Table 33. Document revision history

Date	Revision	Changes
21-Jun-2004	12	Document updating.
03-Aug-2006	13	Order codes has been updated and new template.
19-Jan-2007	14	D ² PAK mechanical data has been updated and add footprint data.
31-May-2007	15	Order codes has been updated.
29-Aug-2007	16	Added Table 1 in cover page.
11-Dec-2007	17	Modified: Table 32 .
06-Feb-2008	18	Added: TO-220 mechanical data Figure 38 on page 40 , Figure 39 on page 41 and Table 24 on page 42 . Modified: Table 32 on page 54 .
18-Mar-2008	19	Added: Table 27: DPAK mechanical data on page 47. , Table 28: Tape and reel DPAK mechanical data on page 48 . Modified: Table 32 on page 54 .

Please Read Carefully:

Information in this document is provided solely in connection with ST products. STMicroelectronics NV and its subsidiaries ("ST") reserve the right to make changes, corrections, modifications or improvements, to this document, and the products and services described herein at any time, without notice.

All ST products are sold pursuant to ST's terms and conditions of sale.

Purchasers are solely responsible for the choice, selection and use of the ST products and services described herein, and ST assumes no liability whatsoever relating to the choice, selection or use of the ST products and services described herein.

No license, express or implied, by estoppel or otherwise, to any intellectual property rights is granted under this document. If any part of this document refers to any third party products or services it shall not be deemed a license grant by ST for the use of such third party products or services, or any intellectual property contained therein or considered as a warranty covering the use in any manner whatsoever of such third party products or services or any intellectual property contained therein.

UNLESS OTHERWISE SET FORTH IN ST'S TERMS AND CONDITIONS OF SALE ST DISCLAIMS ANY EXPRESS OR IMPLIED WARRANTY WITH RESPECT TO THE USE AND/OR SALE OF ST PRODUCTS INCLUDING WITHOUT LIMITATION IMPLIED WARRANTIES OF MERCHANTABILITY, FITNESS FOR A PARTICULAR PURPOSE (AND THEIR EQUIVALENTS UNDER THE LAWS OF ANY JURISDICTION), OR INFRINGEMENT OF ANY PATENT, COPYRIGHT OR OTHER INTELLECTUAL PROPERTY RIGHT.

UNLESS EXPRESSLY APPROVED IN WRITING BY AN AUTHORIZED ST REPRESENTATIVE, ST PRODUCTS ARE NOT RECOMMENDED, AUTHORIZED OR WARRANTED FOR USE IN MILITARY, AIR CRAFT, SPACE, LIFE SAVING, OR LIFE SUSTAINING APPLICATIONS, NOR IN PRODUCTS OR SYSTEMS WHERE FAILURE OR MALFUNCTION MAY RESULT IN PERSONAL INJURY, DEATH, OR SEVERE PROPERTY OR ENVIRONMENTAL DAMAGE. ST PRODUCTS WHICH ARE NOT SPECIFIED AS "AUTOMOTIVE GRADE" MAY ONLY BE USED IN AUTOMOTIVE APPLICATIONS AT USER'S OWN RISK.

Resale of ST products with provisions different from the statements and/or technical features set forth in this document shall immediately void any warranty granted by ST for the ST product or service described herein and shall not create or extend in any manner whatsoever, any liability of ST.

ST and the ST logo are trademarks or registered trademarks of ST in various countries.

Information in this document supersedes and replaces all information previously supplied.

The ST logo is a registered trademark of STMicroelectronics. All other names are the property of their respective owners.

© 2008 STMicroelectronics - All rights reserved

STMicroelectronics group of companies

Australia - Belgium - Brazil - Canada - China - Czech Republic - Finland - France - Germany - Hong Kong - India - Israel - Italy - Japan - Malaysia - Malta - Morocco - Singapore - Spain - Sweden - Switzerland - United Kingdom - United States of America

www.st.com