Features

- Direct Supply from the Mains
- Current Consumption ≤ 0.5 mA
- Very Few External Components
- Full-wave Drive – No DC Current Component in the Load Circuit
- Negative Output Current Pulse Typically 100 mA – Short-circuit Protected
- Simple Power Control
- Ramp Generator
- Reference Voltage

Applications

- Full-wave Power Control
- Temperature Regulation
- Power Blinking Switch

1. Description

The integrated circuit, T2117, is designed as a zero-voltage switch in bipolar technology. It is used to control resistive loads at mains by a triac in zero-crossing mode. A ramp generator allows power control function by period group control, whereas full-wave logic guarantees that full mains cycles are used for load switching.



Zero-voltage Switch with Adjustable Ramp

T2117

Rev. 4768B-INDCO-10/05



Figure 1-1. Block Diagram with Typical Circuit, Period Group Control 0 to 100%

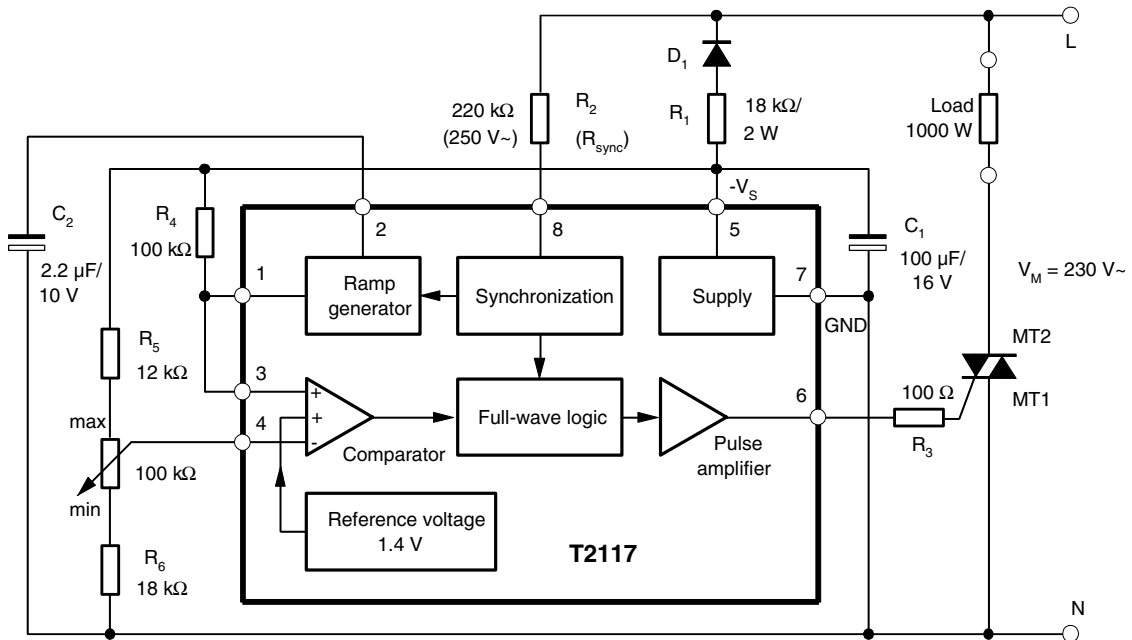

2. Pin Configuration

Figure 2-1. Pinning DIP8/SO8

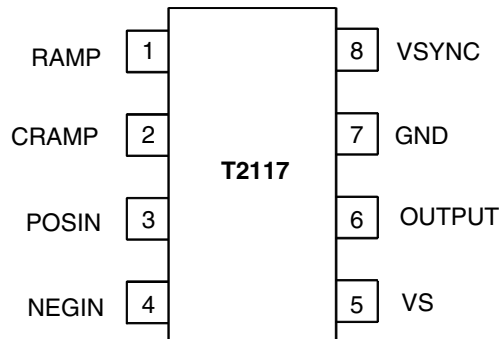

Table 2-1. Pin Description

Pin	Symbol	Function
1	RAMP	Ramp output
2	CRAMP	Ramp capacitor
3	POSIN	Non-inverting comparator input
4	NEGIN	Inverting comparator input
5	VS	Supply voltage
6	OUTPUT	Trigger pulse output
7	GND	Ground
8	VSYNC	Voltage synchronization

3. General Description

The integrated circuit T2117 is a triac controller for zero-crossing mode. It is designed to control power in switching resistive loads of mains supplies.

Information regarding synchronous supply is provided at pin 8 via resistor R_{Sync} . To avoid a DC load on the mains, the full-wave logic guarantees that complete mains cycles are used for load switching.

A fire pulse is released when the inverting input of the comparator is negative (pin 4) with respect to the non-inverting input (pin 3) and internal reference voltage. A ramp generator with freely selectable duration can be performed by capacitor C_2 at pin 2. The ramp function is used for open-loop control (Figure 3-2), but also for applications with proportional band regulation (Figure 10-3 on page 10). Ramp voltage available at capacitor C_2 is decoupled across the emitter follower at pin 1. To maintain the lamp flicker specification, the ramp duration is adjusted according to the controlling load. One can use internal reference voltage for simple applications. In that case, pin 3 is inactive and connected to pin 7 (GND), see Figure 10-5 on page 12.

Figure 3-1. Pin 1 Internal Network

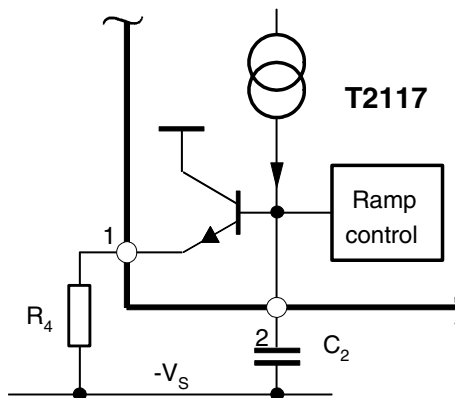
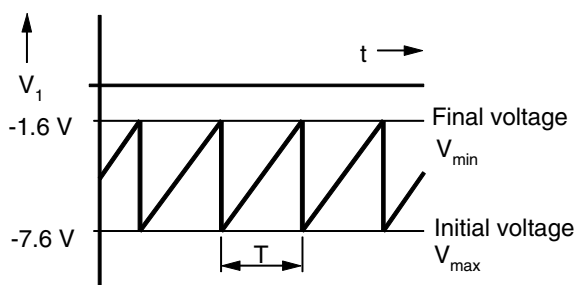

Figure 3-2. Threshold Voltage of the Ramp at $V_S = -8.8\text{ V}$



4. Triac Firing Current (Pulse)

This depends on the triac requirement. It can be limited by the gate series resistance which is calculated as follows:

$$R_{Gmax} \approx \frac{7.5 \text{ V} - V_{Gmax}}{I_{Gmax}} - 36 \Omega$$

$$I_P = \frac{I_{Gmax}}{T} \times t_p$$

where:

V_G = Gate voltage

I_{Gmax} = Maximum gate current

I_p = Average gate current

t_p = Firing pulse width

T = Mains period duration

5. Firing Pulse Width t_p

This depends on the latching current of the triac and its load current. The firing pulse width is determined by the zero-crossing detection which can be influenced by the synchronous resistance, R_{sync} , (see [Figure 5-2 on page 5](#)).

$$t_p = \frac{2}{\omega} \arcsin\left(\frac{I_L \times V_M}{P \sqrt{2}}\right)$$

where

I_L = Latching current of the triac

V_M = Mains supply, effective

P = Load power

The total current consumption is influenced by the firing pulse width which can be calculated as follows:

$$R_{sync} = \frac{V_M \sqrt{2} \sin\left(\omega \times \frac{t_p}{2}\right) - 0.6 \text{ V}}{3.5 \times 10^{-5} \text{ A}} - 49 \text{ k}\Omega$$

Figure 5-1. Output Pulse Width

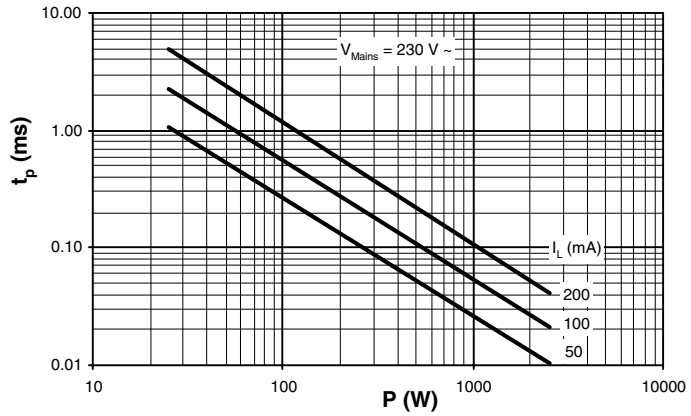
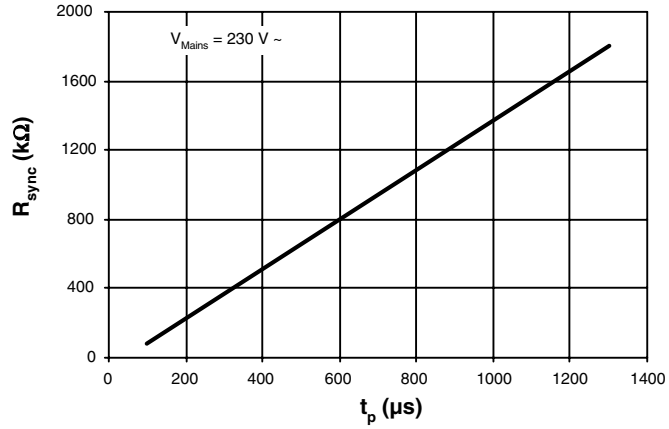

Figure 5-2. Synchronization Resistance



6. Supply Voltage

The T2117 contains a voltage limiting function and can be connected with the mains supply via the diode D_1 and the resistor R_1 . The supply voltage between pin 5 and 7 is limited to a typical value of 9.5 V.

The series resistance R_1 can be calculated as follows (Figure 6-1 on page 6 and Figure 6-2 on page 7):

$$R_{1\max} = 0.85 \frac{V_{M\min} - V_{S\max}}{2 I_{\text{tot}}}; P_{(R1)} = \frac{(V_M - V_S)^2}{2 R_1}$$

$$I_{\text{tot}} = I_S + I_P + I_x$$

where

V_M = Mains voltage

V_S = Limiting voltage of the IC

I_{tot} = Total current consumption

I_S = Current requirement of the IC (without load)

I_x = Current requirement of other peripheral components

$P_{(R1)}$ = Power dissipation at R_1

Figure 6-1. Maximum Resistance of R_1

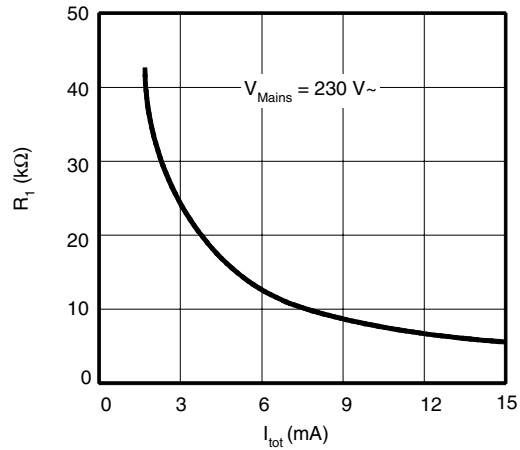
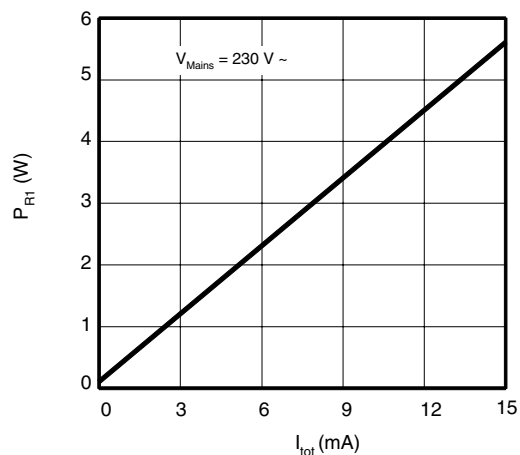

Figure 6-2. Power Dissipation of R₁ According to Current Consumption

7. Absolute Maximum Ratings

Stresses beyond those listed under “Absolute Maximum Ratings” may cause permanent damage to the device. This is a stress rating only and functional operation of the device at these or any other conditions beyond those indicated in the operational sections of this specification is not implied. Exposure to absolute maximum rating conditions for extended periods may affect device reliability.

Parameters	Pin	Symbol	Value	Unit
Supply current	5	$-I_S$	30	mA
Synchronous current	8	I_{sync}	5	mA
Output current ramp generator	1	I_O	3	mA
Input voltages	1, 3, 4, 6	$-V_I$	$\frac{2}{3}V_S$	V
	2	$-V_I$	2 to V_S	V
	8	$\pm V_I$	± 3	V
Power dissipation		P_{tot}	400	mW
		P_{tot}	125	mW
Junction temperature		T_j	125	°C
Operating ambient temperature range		T_{amb}	0 to 100	°C
Storage temperature range		T_{stg}	-40 to +125	°C

8. Thermal Resistance

Parameters	Symbol	Value	Unit
Junction ambient SO8	R_{thJA}	200	K/W
Junction ambient DIP8	R_{thJA}	110	K/W

9. Electrical Characteristics

$-V_S = 8.8\text{ V}$, $T_{\text{amb}} = 25^\circ\text{C}$, reference point pin 7, unless otherwise specified

Parameters	Test Conditions	Pin	Symbol	Min.	Typ.	Max.	Unit
Supply-voltage limitation	$-I_S = 1\text{ mA}$	5	$-V_S$	9.0	9.5	10.0	V
	$-I_S = 10\text{ mA}$		$-V_S$	9.1	9.6	10.1	V
Supply current		5	$-I_S$			500	μA
Voltage limitation	$I_B = \pm 1\text{ mA}$	8	$\pm V_I$	7.7	8.2	8.7	V
Synchronization current		8	$\pm I_{\text{sync}}$	0.12			mA
Zero detector		8	$\pm I_{\text{sync}}$		35		μA
Output pulse width	$V_M = 230\text{ V} \sim$ $R_{\text{sync}} = 220\text{ k}\Omega$ $R_{\text{sync}} = 470\text{ k}\Omega$	6	t_P		260		μs
		6	t_P		460		μs
Output pulse current	$V_6 = 0\text{ V}$	6	$-I_O$	100			mA
Comparator							
Input offset voltage		3, 4	$\pm V_{I0}$			15	mV
Input bias current		4	I_{IB}			1	μA
Common-mode input voltage		3, 4	$-V_{IC}$	1		$(V_S - 1)$	V
Threshold internal reference	$V_3 = 0\text{ V}$	4	$-V_{\text{Ref}}$		1.4		V
Ramp Generator, Figure 1-1 on page 2							
Period	$-I_S = 1\text{ mA}$ $I_{\text{sync}} = 1\text{ mA}$ $C_1 = 100\text{ }\mu\text{F}$ $C_2 = 2.2\text{ }\mu\text{F}$ $R_4 = 100\text{ k}\Omega$	1	T		1.5		s
Final voltage		1	$-V_1$	1.2	1.6	2.0	V
Initial voltage		1	$-V_1$	7.2	7.6	8.0	V
Charge current	$V_2 = -V_S$, $I_B = -1\text{ mA}$	2	$-I_2$	14	20	26	μA

10. Applications

Figure 10-1. Power Blinking Switch with $f \approx 2.7$ Hz, Duty Cycle 1:1, Power Range 0.5 to 2.2 kW

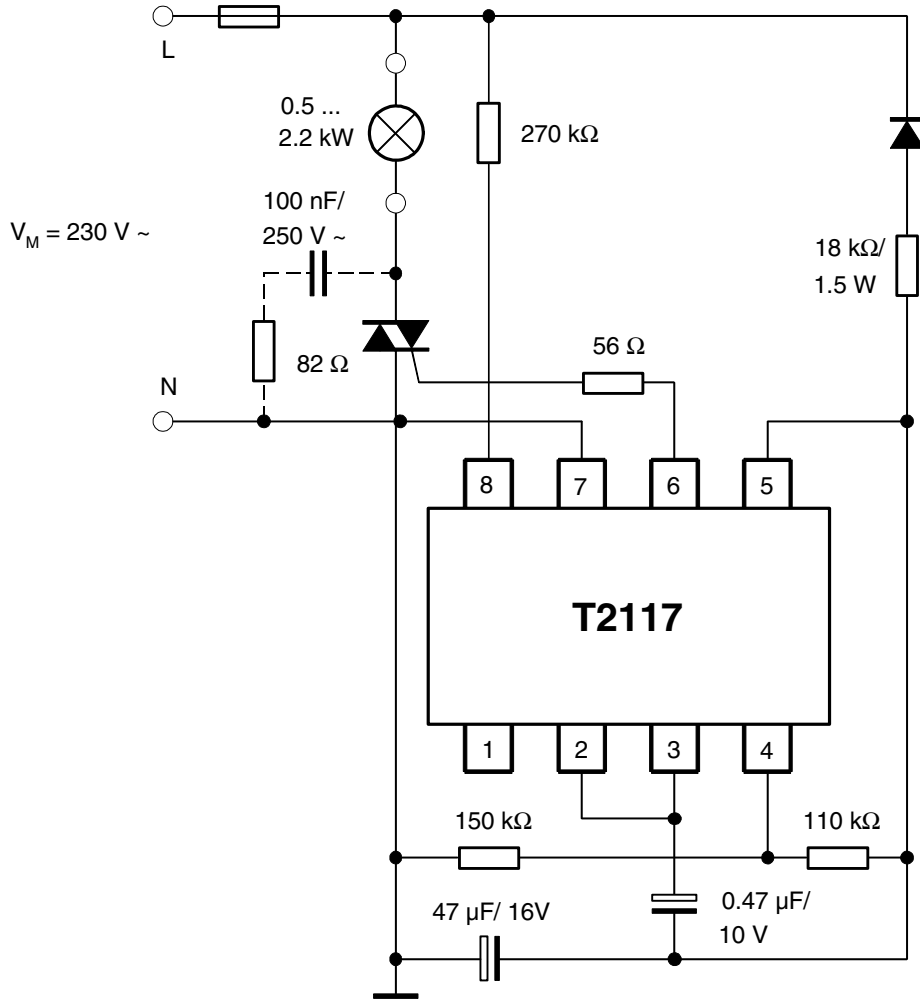

Figure 10-2. Power Switch

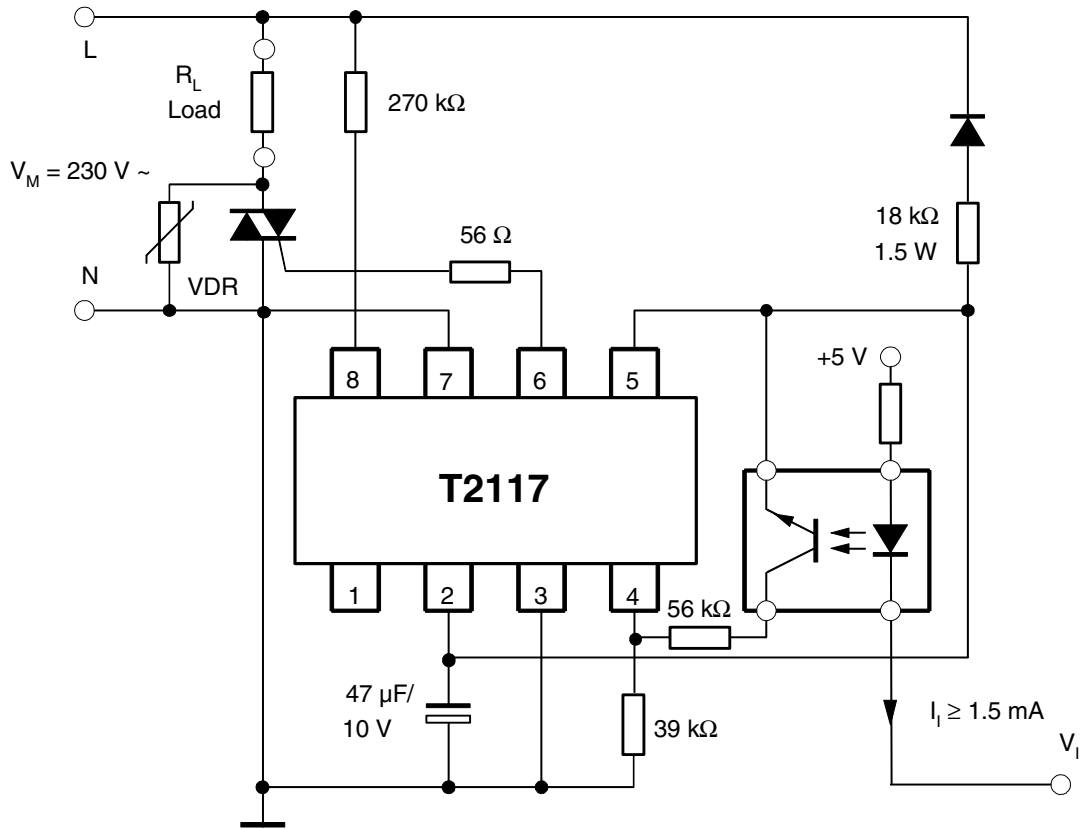
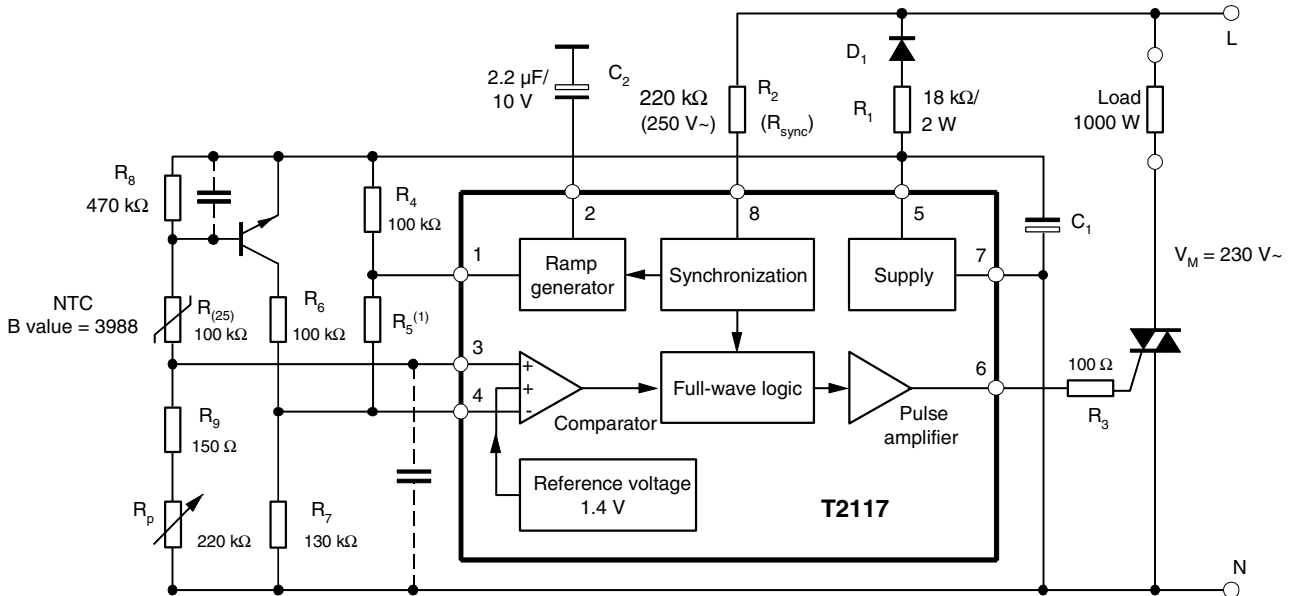

Figure 10-3. Temperature Control 15°C to 35°C with Sensor Monitoring



$R_{(25)} = 100 \text{ k}\Omega / B = 3988 \rightarrow R_{(15)} = 159 \text{ k}\Omega, R_{(35)} = 64.5 \text{ k}\Omega, R_{5(1)}$ determines the proportional range.

Figure 10-4. Room Temperature Control with Definite Reduction (Remote Control) for a Temperature Range of 5 to 30°C

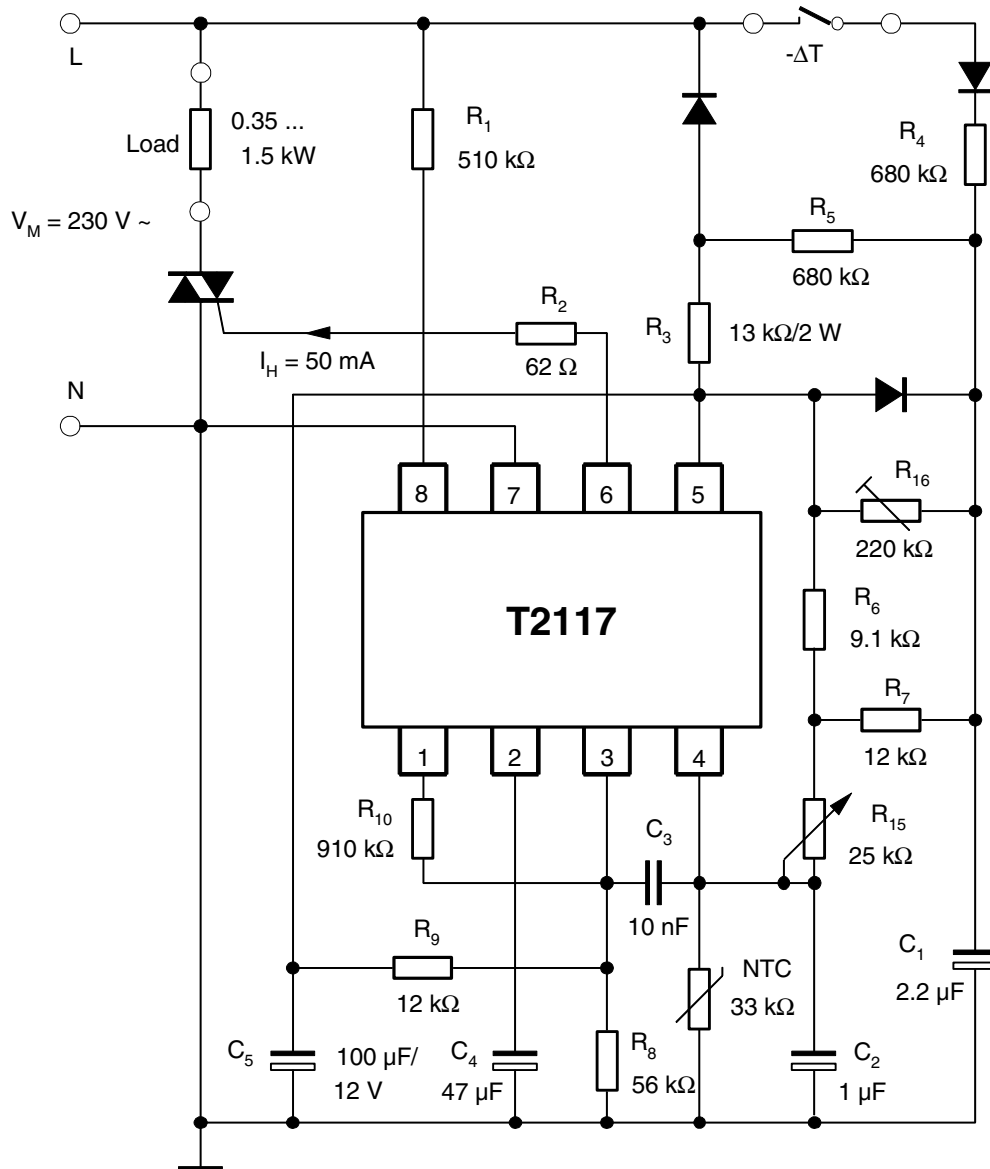

Figure 10-5. Two-point Temperature Control for a Temperature Range of 15°C to 30°C

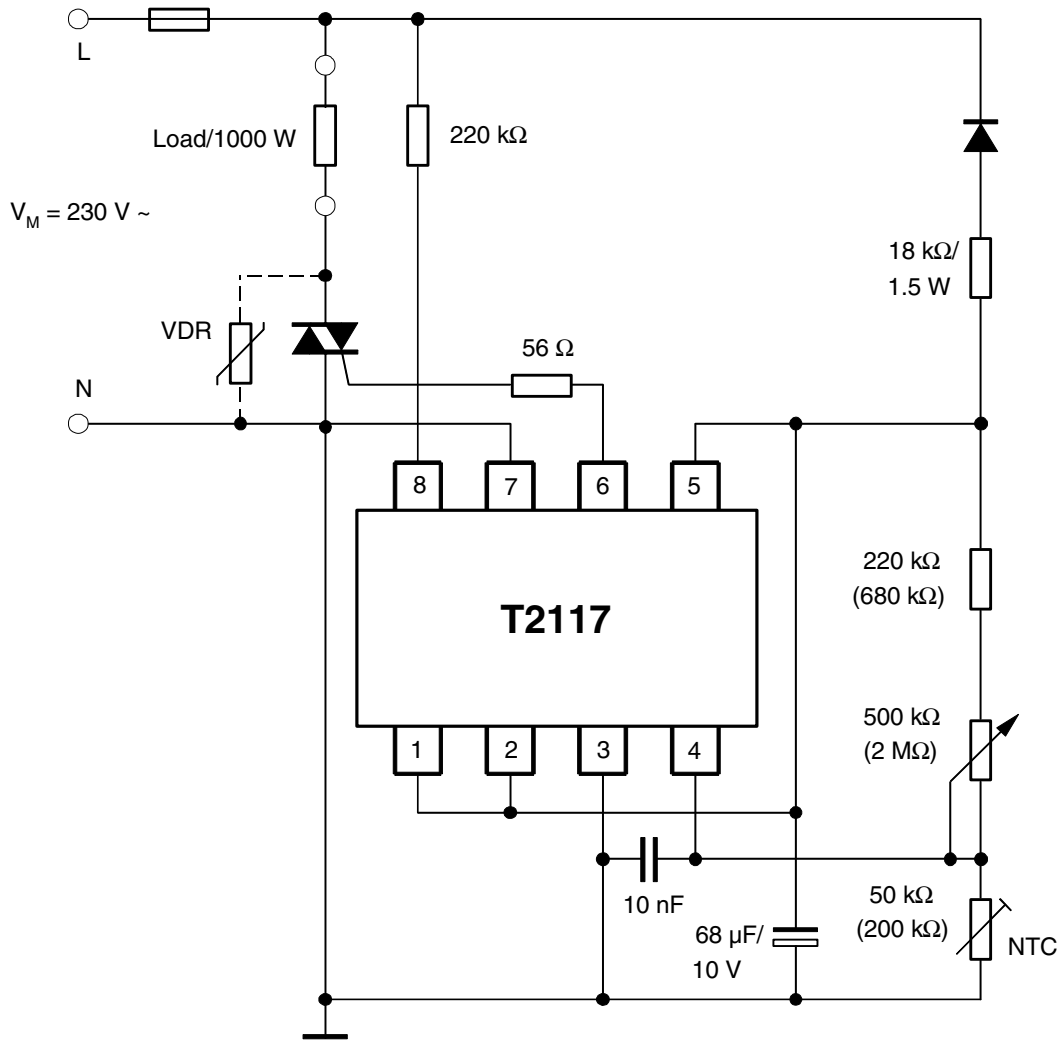
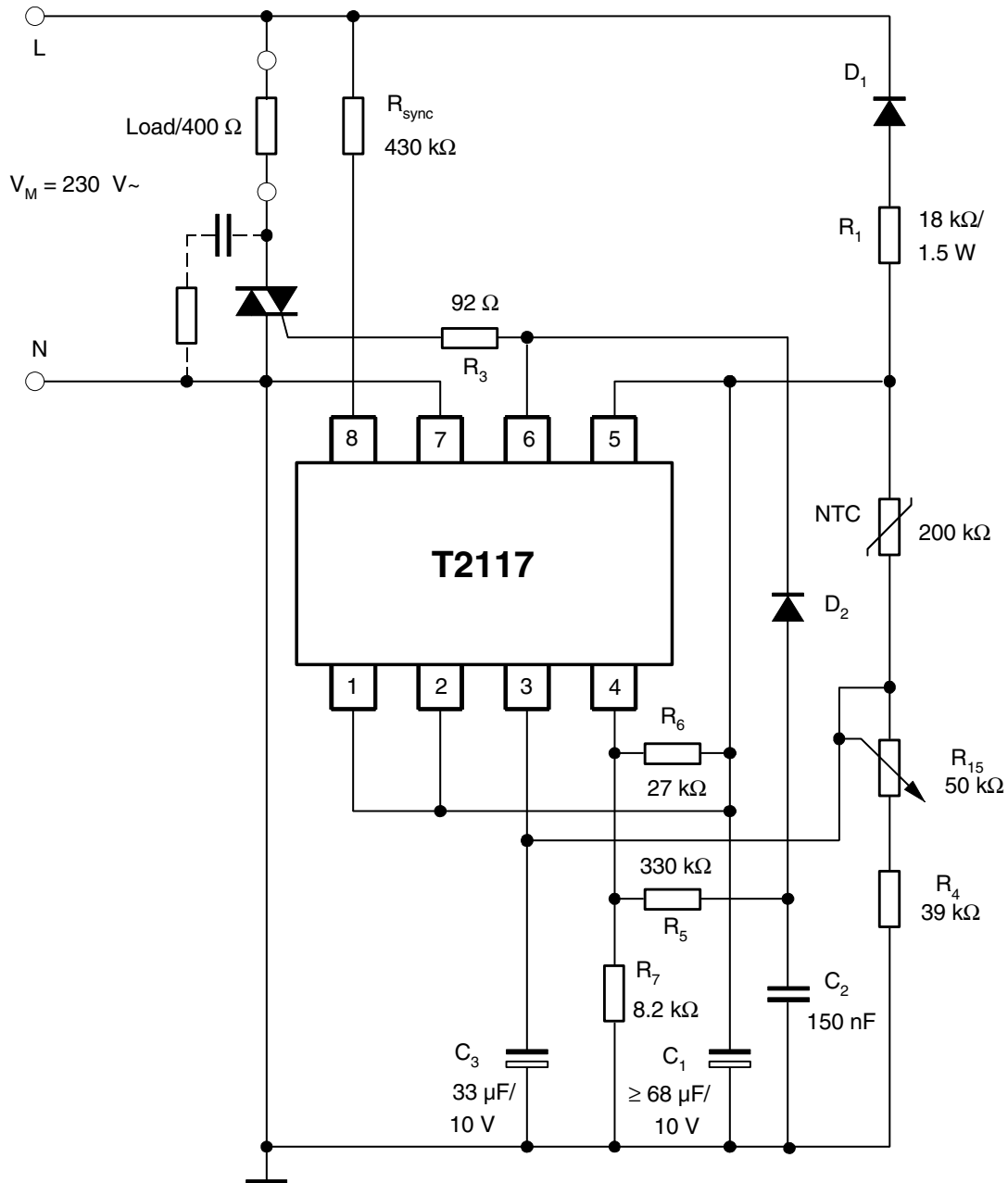

Figure 10-6. Two-point Temperature Control for a Temperature of 18° C to 32° C and a Hysteresis of ±0.5° C at 25° C



11. Ordering Information

Extended Type Number	Package	Remarks
T2117-3ASY	DIP8	Tube, Pb-free
T2117-TASY	SO8	Tube, Pb-free
T2117-TAQY	SO8	Taped and reeled, Pb-free

12. Package Information

Package DIP8
Dimensions in mm

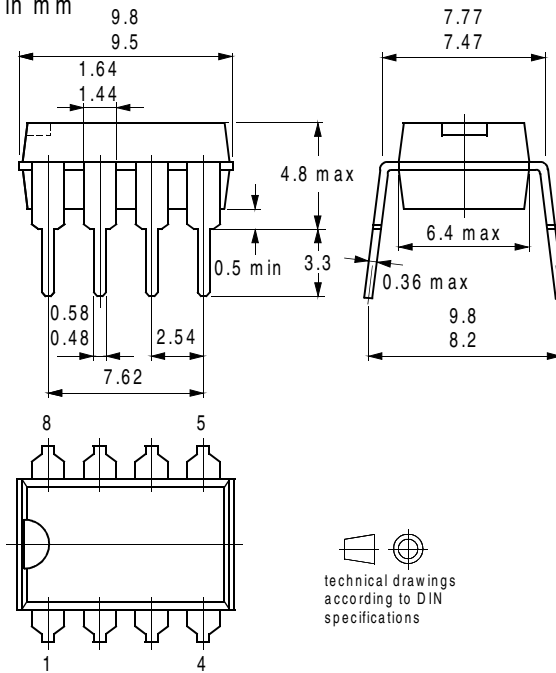

Package SO8
Dimensions in mm

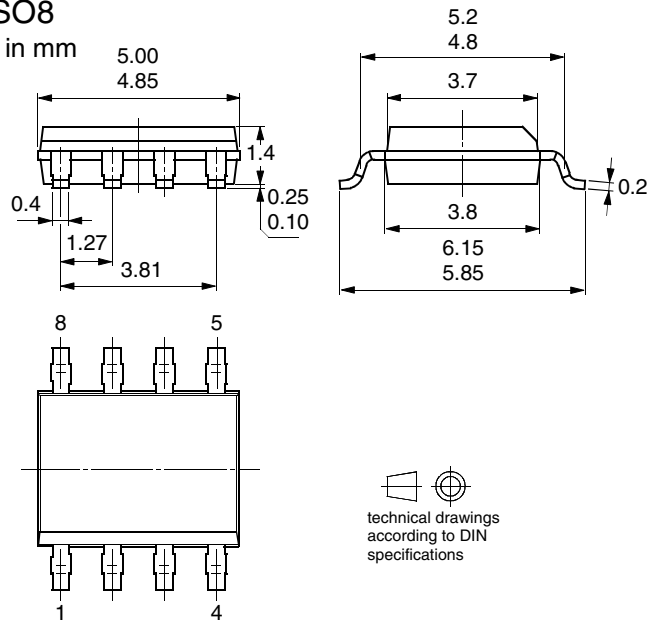

13. Revision History

Please note that the following page numbers referred to in this section refer to the specific revision mentioned, not to this document.

Revision No.	History
4768B-INDCO-08/05	<ul style="list-style-type: none">• Put datasheet in a new template• First page: Pb-free logo added• Page 13: Ordering Information changed



Atmel Corporation

2325 Orchard Parkway
San Jose, CA 95131, USA
Tel: 1(408) 441-0311
Fax: 1(408) 487-2600

Regional Headquarters

Europe

Atmel Sarl
Route des Arsenaux 41
Case Postale 80
CH-1705 Fribourg
Switzerland
Tel: (41) 26-426-5555
Fax: (41) 26-426-5500

Asia

Room 1219
Chinachem Golden Plaza
77 Mody Road Tsimshatsui
East Kowloon
Hong Kong
Tel: (852) 2721-9778
Fax: (852) 2722-1369

Japan

9F, Tonetsu Shinkawa Bldg.
1-24-8 Shinkawa
Chuo-ku, Tokyo 104-0033
Japan
Tel: (81) 3-3523-3551
Fax: (81) 3-3523-7581

Atmel Operations

Memory

2325 Orchard Parkway
San Jose, CA 95131, USA
Tel: 1(408) 441-0311
Fax: 1(408) 436-4314

Microcontrollers

2325 Orchard Parkway
San Jose, CA 95131, USA
Tel: 1(408) 441-0311
Fax: 1(408) 436-4314

La Chantrerie
BP 70602
44306 Nantes Cedex 3, France
Tel: (33) 2-40-18-18-18
Fax: (33) 2-40-18-19-60

ASIC/ASSP/Smart Cards

Zone Industrielle
13106 Rousset Cedex, France
Tel: (33) 4-42-53-60-00
Fax: (33) 4-42-53-60-01

1150 East Cheyenne Mtn. Blvd.
Colorado Springs, CO 80906, USA
Tel: 1(719) 576-3300
Fax: 1(719) 540-1759

Scottish Enterprise Technology Park
Maxwell Building
East Kilbride G75 0QR, Scotland
Tel: (44) 1355-803-000
Fax: (44) 1355-242-743

RF/Automotive

Theresienstrasse 2
Postfach 3535
74025 Heilbronn, Germany
Tel: (49) 71-31-67-0
Fax: (49) 71-31-67-2340

1150 East Cheyenne Mtn. Blvd.
Colorado Springs, CO 80906, USA
Tel: 1(719) 576-3300
Fax: 1(719) 540-1759

Biometrics/Imaging/Hi-Rel MPU/ High Speed Converters/RF Datacom

Avenue de Rochepleine
BP 123
38521 Saint-Egreve Cedex, France
Tel: (33) 4-76-58-30-00
Fax: (33) 4-76-58-34-80

Literature Requests

www.atmel.com/literature

Disclaimer: The information in this document is provided in connection with Atmel products. No license, express or implied, by estoppel or otherwise, to any intellectual property right is granted by this document or in connection with the sale of Atmel products. **EXCEPT AS SET FORTH IN ATMEL'S TERMS AND CONDITIONS OF SALE LOCATED ON ATMEL'S WEB SITE, ATMEL ASSUMES NO LIABILITY WHATSOEVER AND DISCLAIMS ANY EXPRESS, IMPLIED OR STATUTORY WARRANTY RELATING TO ITS PRODUCTS INCLUDING, BUT NOT LIMITED TO, THE IMPLIED WARRANTY OF MERCHANTABILITY, FITNESS FOR A PARTICULAR PURPOSE, OR NON-INFRINGEMENT. IN NO EVENT SHALL ATMEL BE LIABLE FOR ANY DIRECT, INDIRECT, CONSEQUENTIAL, PUNITIVE, SPECIAL OR INCIDENTAL DAMAGES (INCLUDING, WITHOUT LIMITATION, DAMAGES FOR LOSS OF PROFITS, BUSINESS INTERRUPTION, OR LOSS OF INFORMATION) ARISING OUT OF THE USE OR INABILITY TO USE THIS DOCUMENT, EVEN IF ATMEL HAS BEEN ADVISED OF THE POSSIBILITY OF SUCH DAMAGES.** Atmel makes no representations or warranties with respect to the accuracy or completeness of the contents of this document and reserves the right to make changes to specifications and product descriptions at any time without notice. Atmel does not make any commitment to update the information contained herein. Unless specifically provided otherwise, Atmel products are not suitable for, and shall not be used in, automotive applications. Atmel's products are not intended, authorized, or warranted for use as components in applications intended to support or sustain life.

© Atmel Corporation 2005. All rights reserved. Atmel®, logo and combinations thereof, Everywhere You Are® and others, are registered trademarks or trademarks of Atmel Corporation or its subsidiaries. Other terms and product names may be trademarks of others.



Printed on recycled paper.

4768B-INDCO-10/05