

## 18W CAR RADIO POWER AMPLIFIER—YD1028

### DESCRIPTION

The YD1028 is an integrated class-B dual output amplifier in a 9-lead single in-line (TO220Z9) plastic power package. The device is primarily developed for car radio applications.

### FEATURES

- \*Requires very few external components for Bridge Tied Load (BTL),Stereo or BTL application;
- \*High output power, Fixed gain, Good ripple rejection;
- \* Identical inputs (inverting and non-inverting),Low offset voltage at output (important for BTL);
- \*Mute/stand-by switch, No switch-on/switch-off plop;
- \*Load dump protection, AC and DC short-circuit-safe to ground and Vcc, Thermally protected;
- \*Reverse polarity safe;
- \*Capability to handle high energy on outputs (Vcc=0V);
- \*Protected against electrostatic discharge.

### BLOCK DIAGRAM

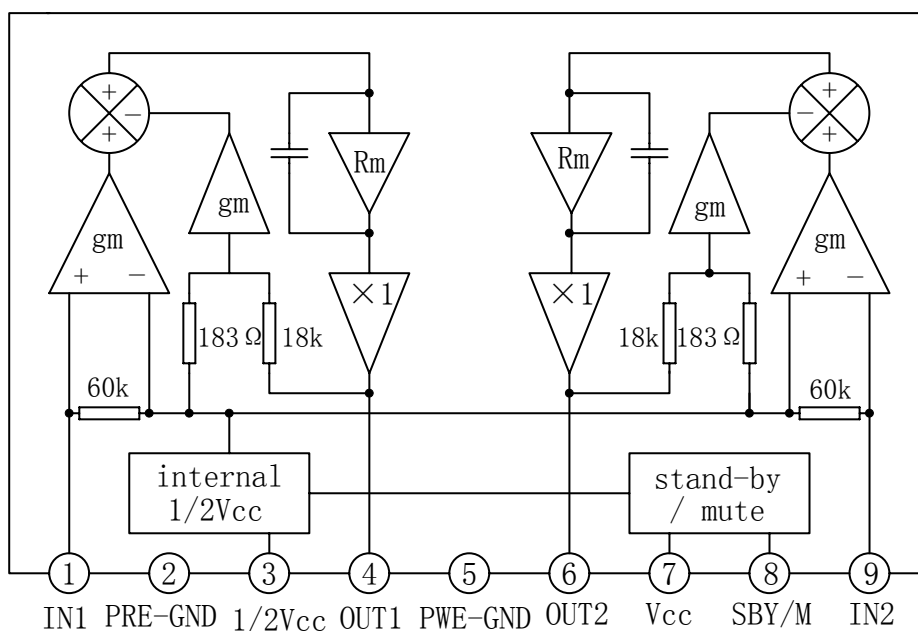

### WuXi YouDa Electronics Co., Ltd

Add: No.5 Xijin Road, National Hi-Tech Industrial Development Zone, Wuxi Jiangsu China

Tel: 86-510-85205117 86-510-85205106 Fax: 86-510-85205110 Website: www.e-youda.com

SHENZHEN OFFICE Tel: 86-755-83740369 Fax: 86-755-83741418

**ABSOLUTE MAXIMUM RATINGS** (Tamb=25°C)

PARAMETER	SYMBOL	TEST CONDITIONS	VALUE	UNIT
Supply Voltage Operating	Vcc		18	V
Non-operating	Vcc		20	V
AC And DC Shot-circuit-safe Voltage	Vccsc		18	V
Reverse Polarity	Vccr		6	V
Non-repetitive Peak Output Current	I <sub>OSM</sub>		4	A
Repetitive Peak Output Current	I <sub>ORM</sub>		2.5	A
Total Power Dissipation	P <sub>D</sub>	Infinite Heat Sink	20	W
		No Heat Sink	4.0	
Operating Temperature	Topr		-20~+75	°C
Storage Temperature	Tstg		-55~+150	°C

**ELECTRICAL CHARACTERISTICS**

**DC CHARACTERISTICS**

(Vcc=13.2V, Tamb=25°C, BTL, unless otherwise specified)

PARAMETER	SYMBOL	TEST CONDITIONS	MIN	TYP	MAX	UNIT
Supply Voltage Range	Vcc		6.0	13.2	18.0	V
Total Quiescent Current	Iccq			40	60	mA
DC Output Voltage	V <sub>o</sub>			6.2		V
DC Output Offset Voltage	ΔV <sub>4-6</sub>	Operating/Mute			250	mV
Switch-on Voltage Level	V <sub>ON</sub>	Operating	8.5			V
Mute Condition	V <sub>mute</sub>	Mute	3.3		6.4	V
Stand-by Condition	V <sub>st-by</sub>	Stand-by			2.0	V
DC Current in Stand-by	Iccsb	V <sub>8</sub> ≤ 2.0V			100	μ A
Control Current in Stand-by	I <sub>8sb</sub>	V <sub>8</sub> ≤ 2.0V		12	40	μ A

**AC CHARACTERISTICS**

(V<sub>cc</sub>=13.2V, R<sub>L</sub>=4 Ω, f=1KHz, T<sub>amb</sub>=25°C; BTL, unless otherwise specified)

PARAMETER	SYMBOL	TEST CONDITIONS	MIN	TYP	MAX	UNIT
Output Power	P <sub>o</sub>	THD=1.0%	12	13		W
		THD=10%	16	18		W
Closed Loop Voltage Gain	G <sub>v</sub>		45	46	47	dB
Total Harmonic Distortion	THD	P <sub>o</sub> =1W		0.1		%
Output Signal In Mute Position	V <sub>o</sub>	V <sub>in</sub> =1V(max.); f=20 Hz to 15 kHz			40	mV
Low Frequency Roll-off	f <sub>L</sub>	-3dB		45		Hz
High Frequency Roll-off	f <sub>H</sub>	-3dB	20			kHz
Supply Voltage Ripple Rejection	RR	ON, V <sub>r</sub> =2Vp-p, R <sub>g</sub> =0, f <sub>r</sub> =100Hz	34			dB
		ON, V <sub>r</sub> =2Vp-p, R <sub>g</sub> =0, f <sub>r</sub> =1kHz~10kHz	48			dB
		Mute V <sub>r</sub> =2Vp-p, R <sub>g</sub> =0, f <sub>r</sub> =100Hz,	48			dB
		Stand-by 1kHz~10kHz	80			dB
Input Impedance	Z <sub>i</sub>		25	30	38	k Ω
Noise Output Voltage (RMS value)	V <sub>no</sub>	ON, R <sub>g</sub> =0 Ω, BPF=20Hz~20kHz		200		μ V
		ON, R <sub>s</sub> =10k Ω BPF=20Hz~20kHz		350	700	μ V
		Mute, BPF=20Hz~20kHz		180		μ V

AC CHARACTERISTICS

V<sub>cc</sub>=13.2V, R<sub>L</sub>=2 Ω, f=1KHz; Tamb=25°C, stereo, unless otherwise specified

PARAMETER	SYMBOL	TEST CONDITIONS	MIN	TYP	MAX	UNIT
Output Power	P <sub>o</sub>	THD=1.0%		8.0		W
		THD=10%		9.0		W
Output Power (V <sub>cc</sub> =14.4V)	P <sub>o</sub>	R <sub>L</sub> =4 Ω, THD=1.0%	4.8	5.0		W
		R <sub>L</sub> =4 Ω, THD=10%	5.8	6.2		W
Closed Loop Voltage Gain	G <sub>v</sub>		39	40	41	dB
Total Harmonic Distortion	THD	P <sub>o</sub> =1W		0.1		%
Output Signal In Mute Position	V <sub>o</sub>	V <sub>in</sub> =1V(max.); f=20 Hz to 15 kHz			20	mV
Low Frequency Roll-off	f <sub>L</sub>	-3dB		45		Hz
High Frequency Roll-off	f <sub>H</sub>	-3dB	20			kHz
Supply Voltage Ripple Rejection	RR	ON, V <sub>r</sub> =2Vp-p, R <sub>g</sub> =0, f <sub>r</sub> =100Hz	40			dB
		ON, V <sub>r</sub> =2Vp-p, R <sub>g</sub> =0, f <sub>r</sub> =1kHz~10kHz	45			dB
		Mute V <sub>r</sub> =2Vp-p, R <sub>g</sub> =0, f <sub>r</sub> =100Hz,	45			dB
		Stand-by 1kHz~10kHz	80			dB
Input Impedance	Z <sub>i</sub>		50	60	75	k Ω
Noise Output Voltage (RMS value)	V <sub>no</sub>	ON, R <sub>g</sub> =0 Ω, BPF=20Hz~20kHz		150	500	μ V
		ON, R <sub>s</sub> =10k Ω BPF=20Hz~20kHz		250		μ V
		Mute, BPF=20Hz~20kHz		120		μ V
Channel Separation	α	R <sub>s</sub> =10k Ω	40			dB
Channel Unbalance	ΔG <sub>v</sub>			0.1	1	dB

APPLICATION CIRCUIT

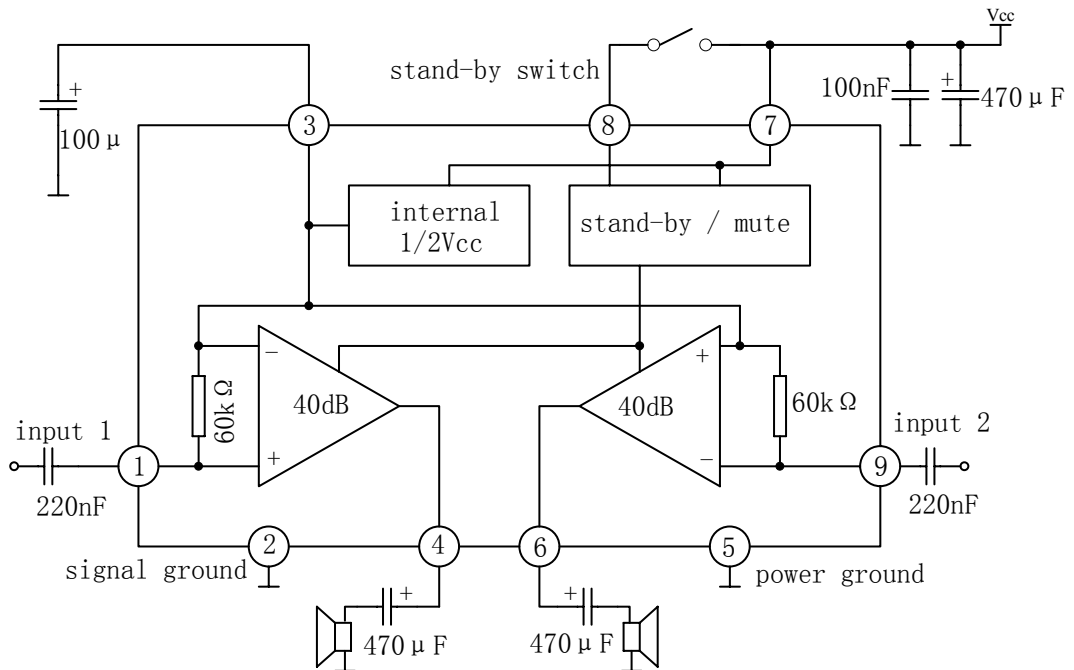

Stereo application circuit diagram

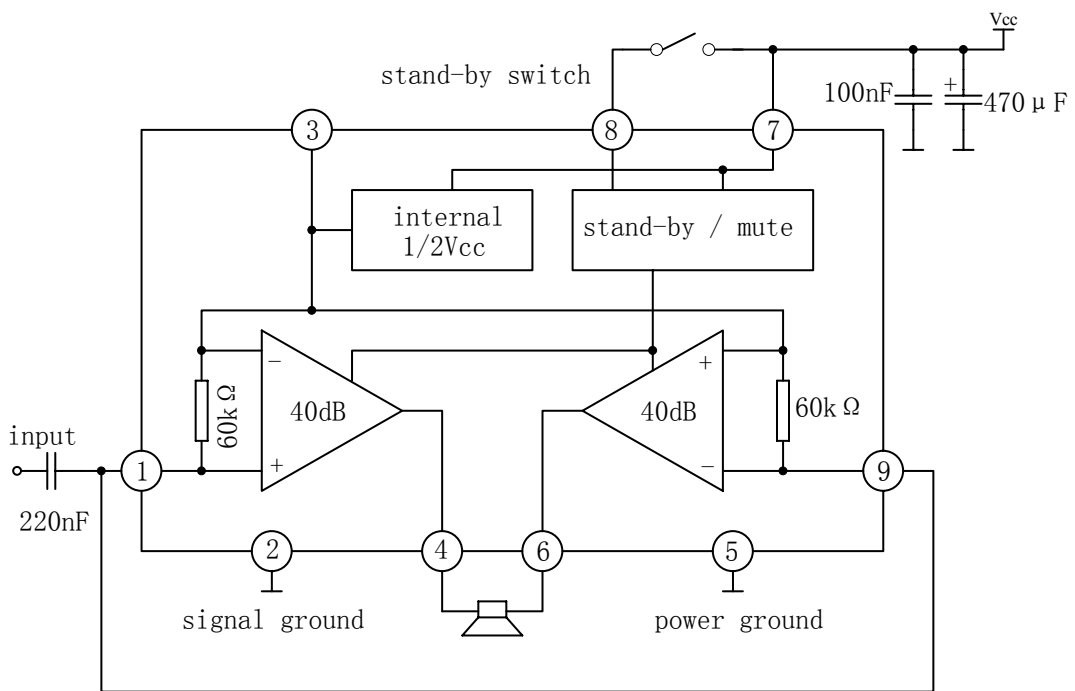

BTL application circuit diagram

