

BIPOLAR ANALOG INTEGRATED CIRCUIT

μ PC1350C

450mW AF POWER AMPLIFIER WITH PRE AMPLIFIER AND ALC CIRCUIT SILICON BIPOLAR MONOLITHIC INTEGRATED CIRCUIT

DESCRIPTION

The μ PC1350C is a silicon monolithic integrated circuit designed for an audio power amplifier application at 6 volts power supply.

The device contains a high gain low noise preamplifier, an automatic level control (ALC) and a high gain low distortion power amplifier.

The perfect audio circuit of a cassette tape recorder is obtained with the device.

FEATURES

- All functions of a preamplifier, an ALC circuit and a power amplifier are encapsulated in a 14-pins dual in-line package with heat sink TAB.
- Low noise, especially low pulsive noise.
- Power amplifier stage has high gain, high output power and low distortion characteristics.
- Preamplifier stage has high gain and low distortion characteristics.
- Wide ALC range: output voltage change 1.8 V TYP., ALC range 60 dB TYP.
- Wide supply operating voltage range: $V_{CC} = 3.5$ to 10 V
- Low spurious radiation when driven to output clipping level.

BLOCK DIAGRAM

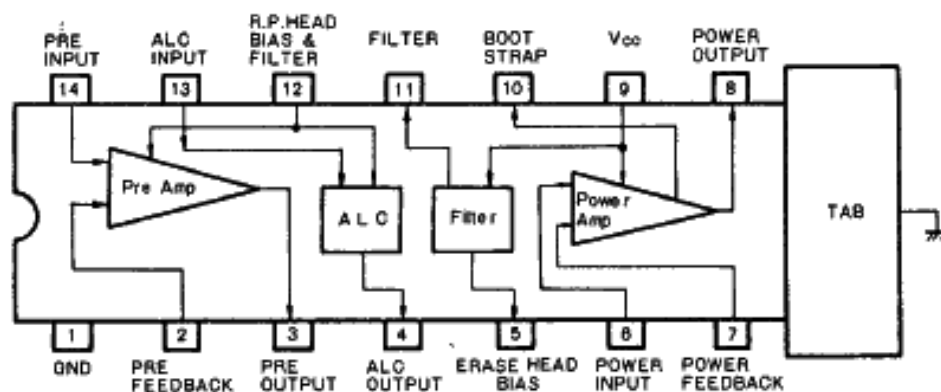

PACKAGE DIMENSIONS AND CONNECTION DIAGRAM (Top View)

in millimeters (inches)

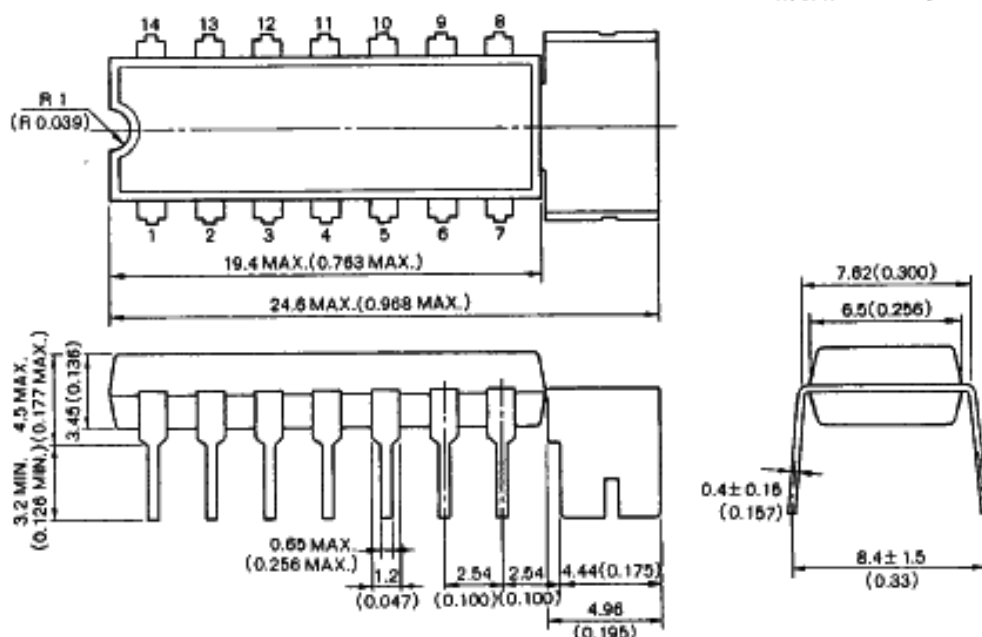

Pin No.	Electrical Connections	Pin No.	Electrical Connections
1	GND	8	Power; Output
2	Pre.; Feedback	9	Power Supply VCC
3	Pre.; Output	10	Boot Strap
4	ALC Output	11	Filter
5	Erase; Head Bias	12	R.P. Head Bias & Filter
6	Power; Input	13	ALC Input
7	Power; Feedback	14	Pre.; Input

ABSOLUTE MAXIMUM RATINGS (Ta = 25 °C)

Supply Voltage (DC)	VCC1	12	V
Supply Voltage (AC)	VCC2	10	V
Circuit Current	ICC(peak)	500	mA
Package Dissipation	PD	2.4*	W
Operating Temperature	Topt	-20 to +75	°C
Storage Temperature	Tstg	-40 to +125	°C

* Mounted and soldered on a 50 mm x 50 mm copper foil of a printed circuit board (XXX3 grade).

RECOMMENDED CONDITIONS ($T_a = 25^\circ\text{C}$)

Operating Supply Voltage	6 V
Supply Voltage Range	3.5 to 10 V

ELECTRICAL CHARACTERISTICS ($T_a = 25^\circ\text{C}$, $V_{CC} = 6\text{ V}$, $f = 1\text{ kHz}$, NAB , $R_L(\text{pre}) = 10\text{ k}\Omega$, $R_L(\text{power}) = 8\ \Omega$)

CHARACTERISTIC	SYMBOL	MIN.	TYP.	MAX.	UNIT	TEST CONDITIONS
[OVER ALL CHARACTERISTIC]						
Circuit Current	I_{CC}	10	20	33	mA	NO SIGNAL
Output Power	P_o	400	450	—	mW	$V_R \rightarrow \text{MAX.}$ T.H.D. = 10 %
Total Harmonic Distortion	T.H.D.	—	0.8	2.0	%	$V_R \rightarrow \text{MAX.}$ $P_o = 50\text{ mW}$
Output Noise Level	NL1	—	10	23	$\text{mV}_{r.m.s.}$	Using P. head as an R_G . $V_R \rightarrow \text{MAX.}$
ALC Characteristic	ALC1	—	1.8	9	dB	$V_i = -70 \text{ --- } -40\text{ dBm}$ $R_L' = 56\ \Omega$
ALC Range	ALC2		60		dB	T.H.D. $\leq 3\%$ $R_L' = 56\ \Omega$
[PRE AMPLIFIER STAGE]						
Open Loop Voltage Gain	A_{v01}	55	65	—	dB	$R_L(\text{pre}) = 10\text{ k}\Omega$ $V_o = 0.3\text{ V}_{r.m.s.}$
Voltage Gain	A_{v2}		30.8		dB	NAB $V_o = 0.3\text{ V}_{r.m.s.}$
Maximum Output Voltage	VOM		0.8	—	$\text{V}_{r.m.s.}$	$R_L(\text{pre}) = 10\text{ k}\Omega$ T.H.D. = 1 %
Input Impedance	R_{i1}	20			$\text{k}\Omega$	
[POWER AMPLIFIER STAGE]						
Open Loop Voltage Gain	A_{v02}	70	81	—	dB	$P_o = 50\text{ mW}$
Voltage Gain	A_{v2}		46.8		dB	$P_o = 50\text{ mW}$
Output Noise Level	NL2	—	0.4	2.0	$\text{mV}_{r.m.s.}$	$V_R \rightarrow \text{MIN.}$ ($R_G = 0$)
Input Impedance	R_{i2}	20	28		$\text{k}\Omega$	

TYPICAL CHARACTERISTICS ($T_a = 25^\circ\text{C}$, TEST CIRCUIT)

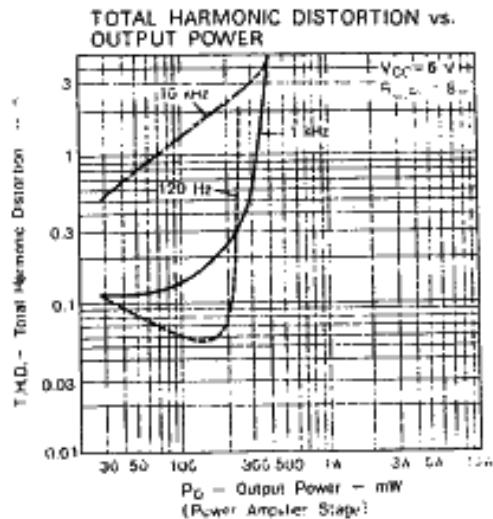
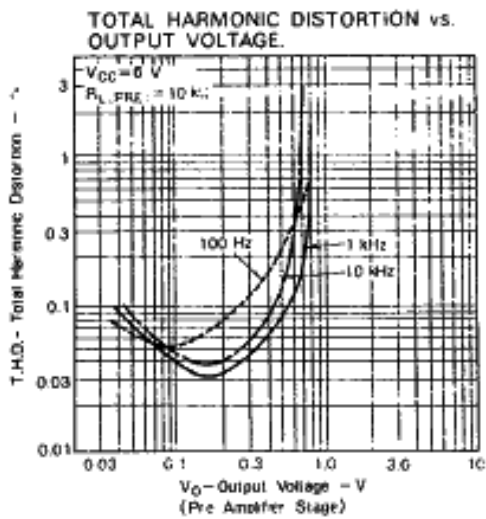

CIRCUIT CURRENT, OUTPUT POWER, MAXIMUM OUTPUT VOLTAGE GAIN vs. AMBIENT TEMPERATURE (PRE AMP. - POWER AMP.)

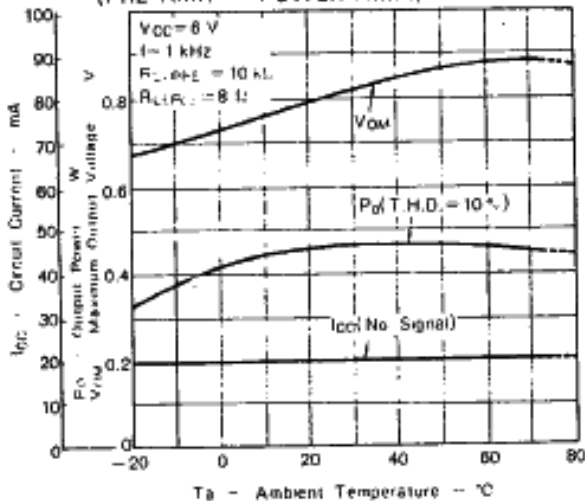

CIRCUIT CURRENT, OVER ALL VOLTAGE GAIN, OUTPUT POWER, MAXIMUM OUTPUT VOLTAGE vs. SUPPLY VOLTAGE

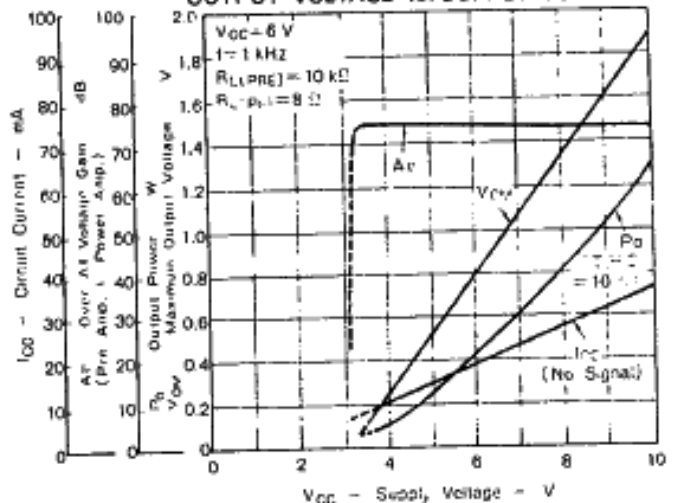

VOLTAGE GAIN vs. FREQUENCY

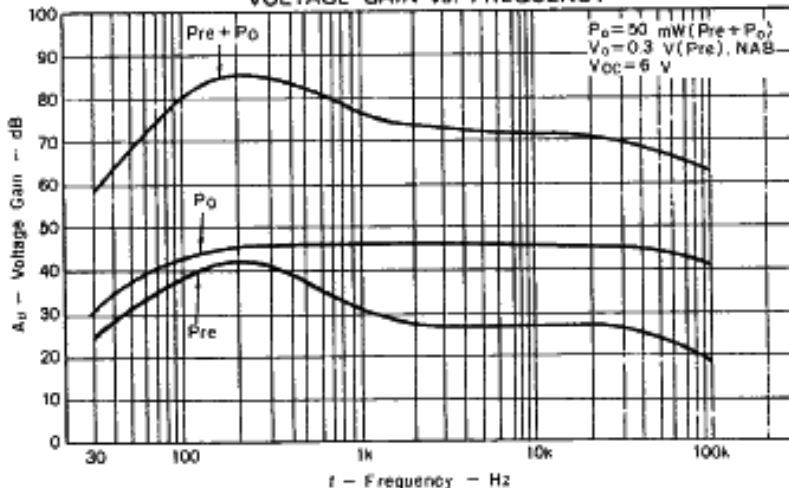

TYPICAL APPLICATION

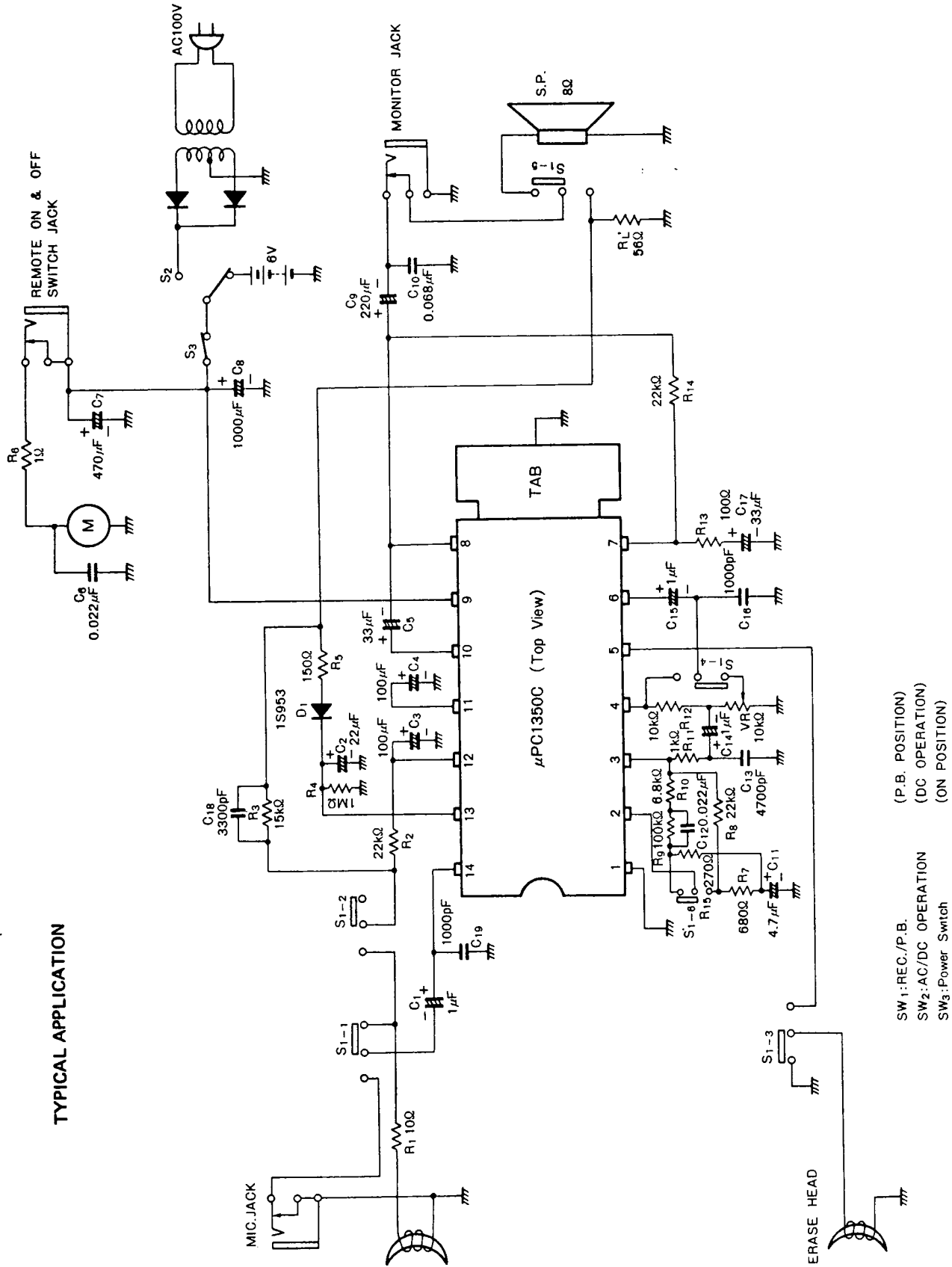

- SW₁: REC./P.B. (P.B. POSITION)
- SW₂: AC/DC OPERATION (DC OPERATION)
- SW₃: Power Switch (ON POSITION)

μPC1350C

6427525 N E C ELECTRONICS INC

72C 08677 DT-74-05-01

TYPICAL CHARACTERISTICS (Ta = 25 °C, TYPICAL APPLICATION CIRCUIT)

RECORDING CHARACTERISTICS

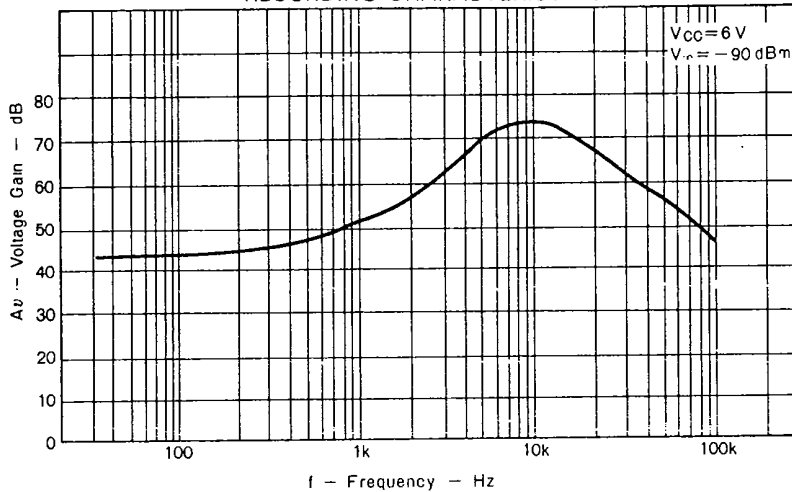

ALC OUTPUT VOLTAGE CHANGE vs. INPUT LEVEL

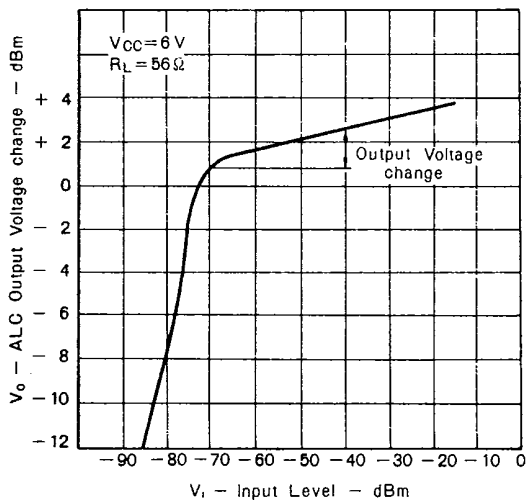

T.H.D. AT ALC OUTPUT vs. INPUT LEVEL

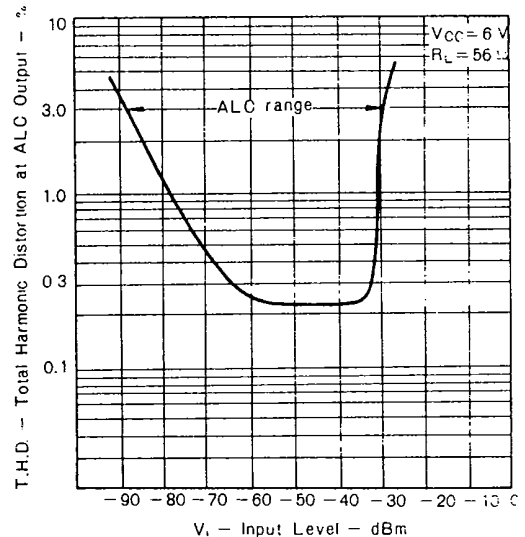

NOTES FOR USE

1. About capacitor C10
 To avoid parasitic oscillation at power amplifier stage, apply the suitable capacitor as C10 as follows.
 For a cassette tape recorder, a ceramic capacitor or a Mylar capacitor can be used equally.
 For a cassette tape recorder with radio, use a Mylar capacitor. If a ceramic capacitor is used, a parasitic oscillation may occur caused by feed back as radiation from the capacitor to an RF stage.
2. About recovery time at recording
 A recovery time depends on a time constant of a capacity value of C2 and a pallel value of R4 and an input impedance of IC at pin 13.
 The recovery time can be adjusted by R4 value.

PRINTED CIRCUIT BOARD DESIGN CONSIDERATION

1. Use the widest possible printed foil for a power supply and a ground.
2. The earthing point of C8, C10 and an output terminal should be located as close as possible to the earthing (ground) pins (pin 1 and TAB).
3. One-point earthing is ideal, but if this is impossible, keep the input loop out of the output loop.

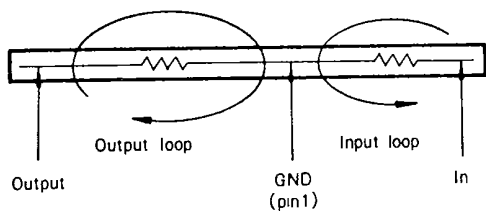

(good example)

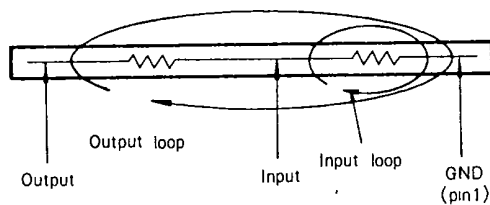

(bad example)