

BIPOLAR ANALOG INTEGRATED CIRCUIT

μ PC1316

DUAL AUDIO POWER AMPLIFIER

DESCRIPTION

The μ PC1316 is a dual audio power amplifier designed for portable audio sets.

FEATURES

- Wide operating voltage range. $V_{CC} = 3$ to 16 V
- High output power. $P_O = 2$ W TYP. @ 12 V / 8Ω / 10 %
 $P_O = 1.6$ W TYP. @ 9 V / 4Ω / 10 %
 $P_O = 1.2$ W TYP. @ 9 V / 8Ω / 10 %
 $P_O = 0.7$ W TYP. @ 6 V / 4Ω / 10 %
 $P_O = 0.5$ W TYP. @ 6 V / 8Ω / 10 %
 $P_O = 80$ mW @ 4.5 V / 32Ω / 10 %
 ($V_{CC} / R_L / THD$)
- High supply voltage rejection. SVR = 45 dB
- Low quiescent current. $I_{CC} = 12$ mA
- Low pop noise at power switch on and off.

BLOCK DIAGRAM

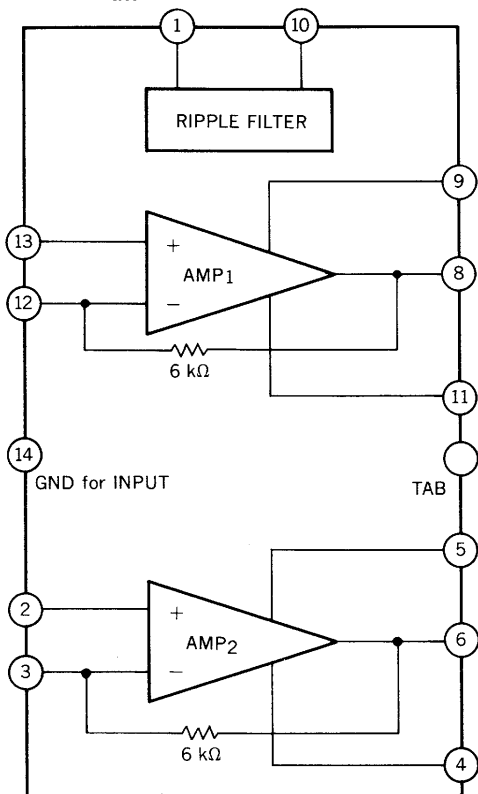

CONNECTION DIAGRAM

PIN NO	CONNECTION
1	Filter
2	Input 2
3	NFB 2
4	Compensation 2
5	Bootstrap 2
6	Output 2
7	NC
TAB	GND
8	Output 1
9	Bootstrap 1
10	V_{CC}
11	Compensation 1
12	NFB 1
13	Input 1
14	GND

ORDERING INFORMATION

PART NUMBER	PACKAGE	QUALITY GRADE
μPC1316C	14 PIN PLASTIC DIP WITH TAB (300 mil)	Standard

Please refer to "Quality grade on NEC Semiconductor Devices" (Document number IEI-1209) published by NEC Corporation to know the specification of quality grade on the devices and its recommended applications.

ABSOLUTE MAXIMUM RATINGS (T_a = 25 °C)

Supply Voltage (No Signal)	V _{CC1}	18	V
Supply Voltage (Operating)	V _{CC2}	16	V
Power Dissipation	P _D	2.4 *	W
Operating Temperature	T _{opt}	-20 to +70	°C
Storage Temperature	T _{stg}	-40 to +150	°C

* 50 x 50 x 0.035 mm Copper heat sink on PCB

RECOMMENDED OPERATING CONDITIONS (T_a = 25 °C)

CHARACTERISTIC	SYMBOL	MIN.	TYP.	MAX.	UNIT
Supply Voltage (R _L =16 Ω)	V _{CC} (16)	3		16	V
Supply Voltage (R _L =8 Ω)	V _{CC} (8)	3		13	V
Supply Voltage (R _L =4 Ω)	V _{CC} (4)	3		9	V
Load Impedance	R _L	4	8		Ω
Voltage Gain	A _v	34	44		dB

ELECTRICAL CHARACTERISTICS (T_a = 25 °C)

(V_{CC}=9 V, R_f=33 Ω, f=1 kHz, R_L=8 Ω)

CHARACTERISTIC	SYMBOL	MIN.	TYP.	MAX.	UNIT	CONDITION
Circuit Current	I _{CC}		12	25	mA	No Signal
Voltage Gain	A _{v1}	41	44	47	dB	P _O =0.25 W, R _f =33 Ω
	A _{v2}		34		dB	P _O =0.25 W, R _f =120 Ω
Output Power	P _{O1}		2		W	V _{CC} =12 V, R _L =8 Ω, THD = 10 %
	P _{O2}		1.6		W	V _{CC} =9 V, R _L =4 Ω, THD = 10 %
	P _{O3}	0.9	1.2		W	V _{CC} =9 V, R _L =8 Ω, THD = 10 %
	P _{O4}		0.7		W	V _{CC} =6 V, R _L =4 Ω, THD = 10 %
	P _{O5}		0.5		W	V _{CC} =6 V, R _L =8 Ω, THD = 10 %
	P _{O6}			80		mW
Total Harmonic Distortion	THD1		0.4	1.6	%	P _O =0.5 W, R _f =33 Ω
	THD2		0.3		%	P _O =0.5 W, R _f =120 Ω
Output Noise Voltage	NL		0.9	1.5	mV _{r.m.s.}	R _G =10 kΩ
Supply Voltage Rejection	SVR	36	45		dB	R _G =0, f(ripple)=100 Hz, V(ripple)=0.3 V _{r.m.s.}
Cross Talk	CT	40	55		dB	R _G =0, P _O =0.25 W
Channel Balance	ChB	-2	0	2	dB	P _O =0.25 W
Input Impedance	Z _{in}		5		MΩ	

TEST CIRCUIT

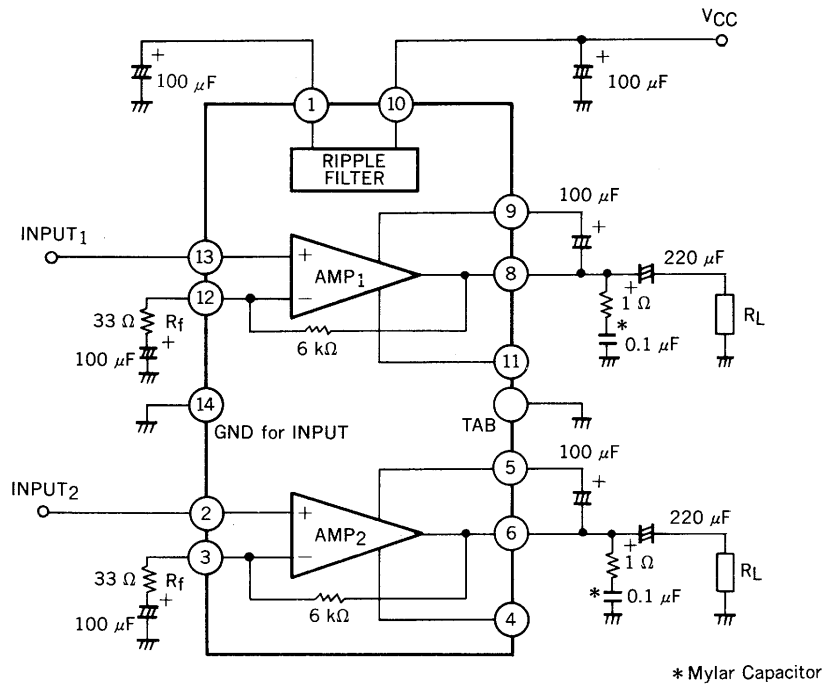

TYPICAL APPLICATION

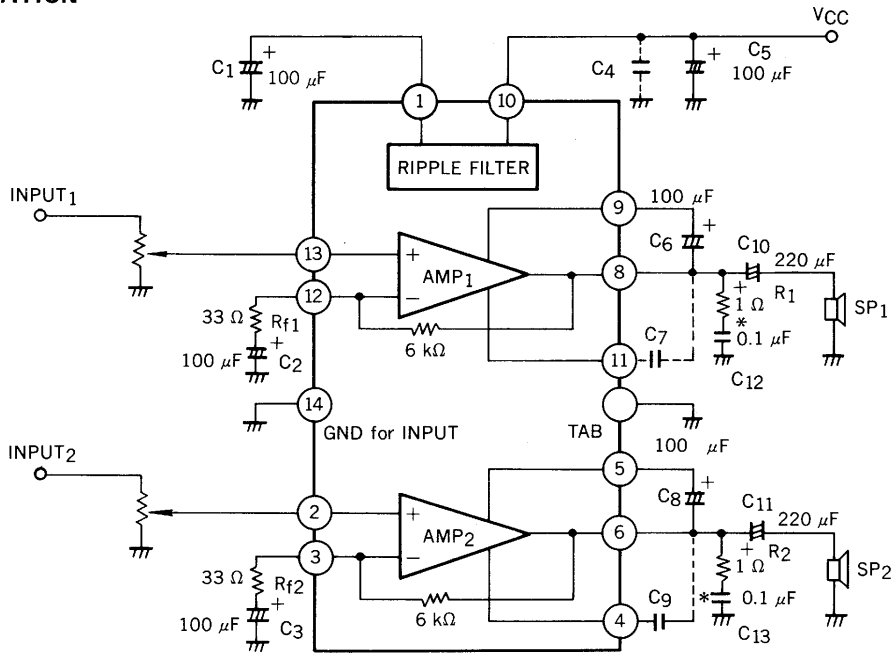

* Mylar Capacitor

NOTE FOR USE

- (1) Mylar capacitor is recommended as C₁₂, C₁₃.
- (2) Add C₇, C₉, in the case of reducing voltage gain at high frequency.
- (3) Add C₄ or increase capacitance of C₁₂, C₁₃ when a oscillation may occur due to the pattern layout on PCB.
- (4) Voltage gain can be changed by value of R_{f1}, R_{f2}. The voltage gain should be set more than 34 dB.
- (5) When a input capacitor is connected the input terminal, a bias resistor should be connected between its terminal and GND.

EXAMPLE FOR PRINTED CIRCUIT BOARD (Copper foil side)

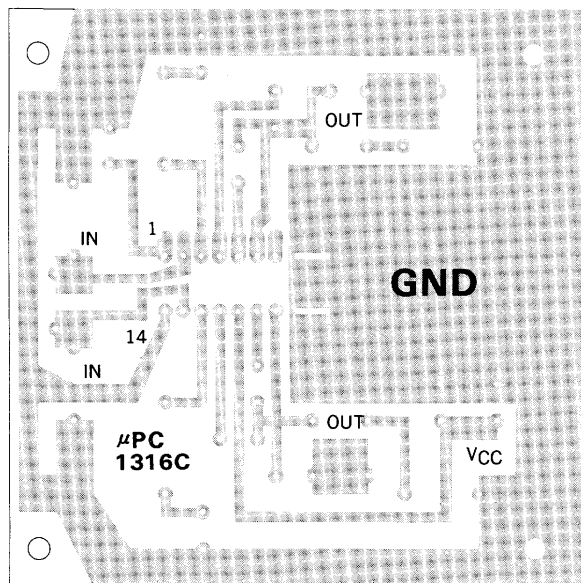

TYPICAL CHARACTERISTICS (T_a = 25 °C)

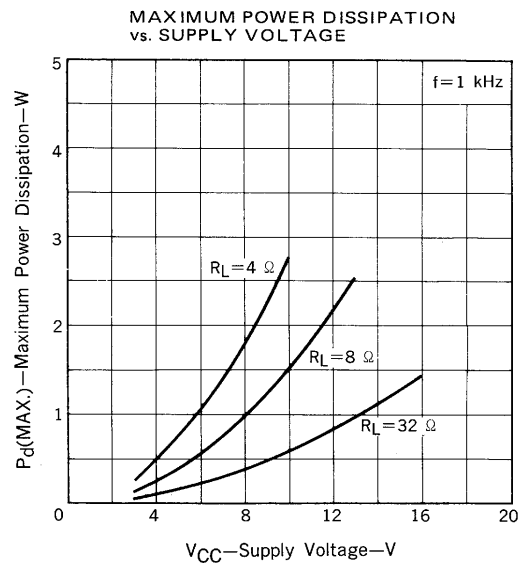
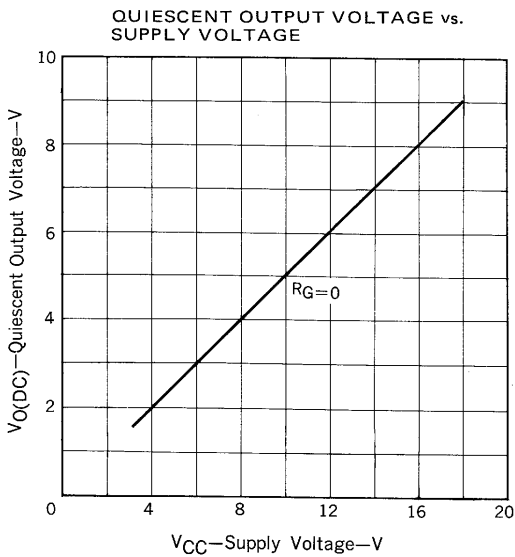
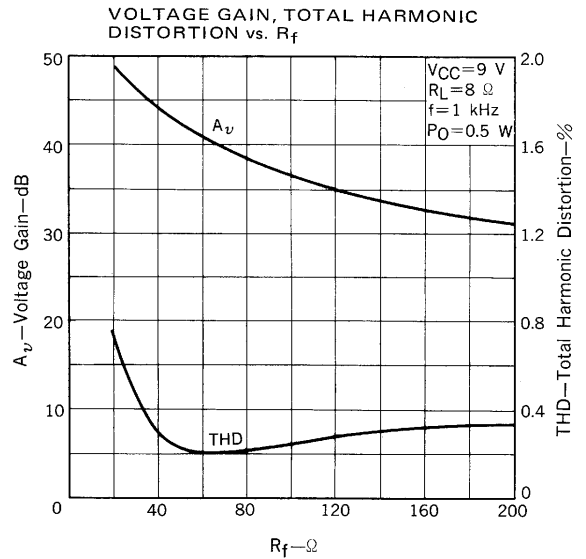
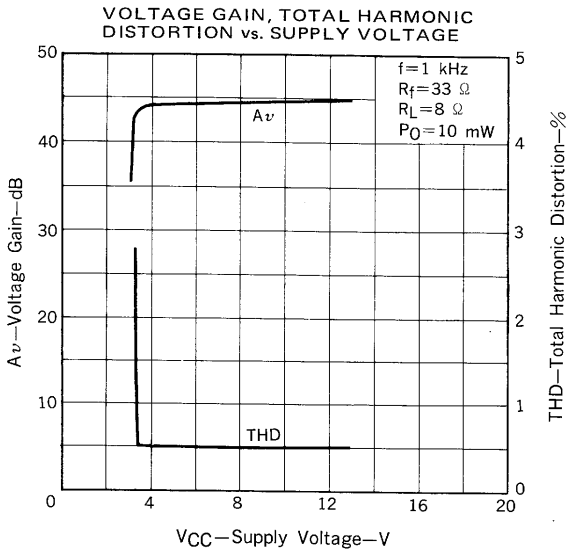
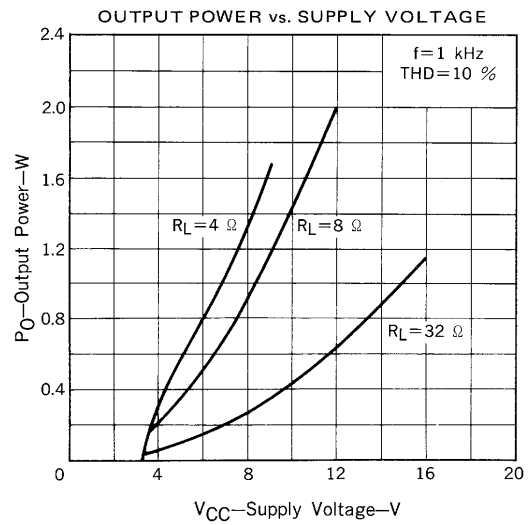
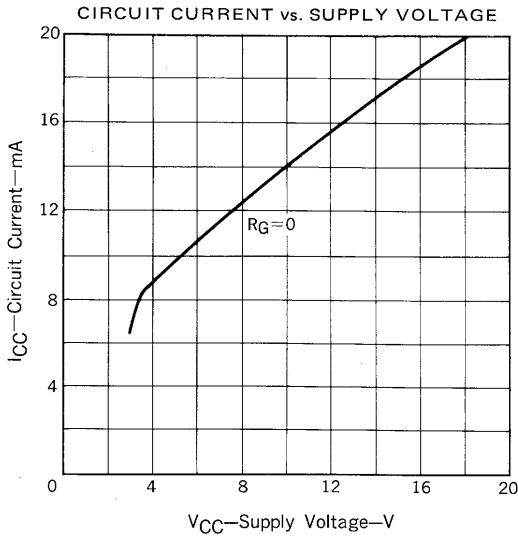

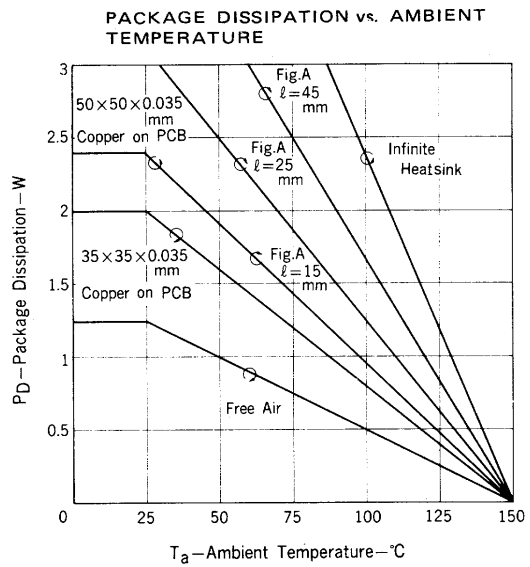
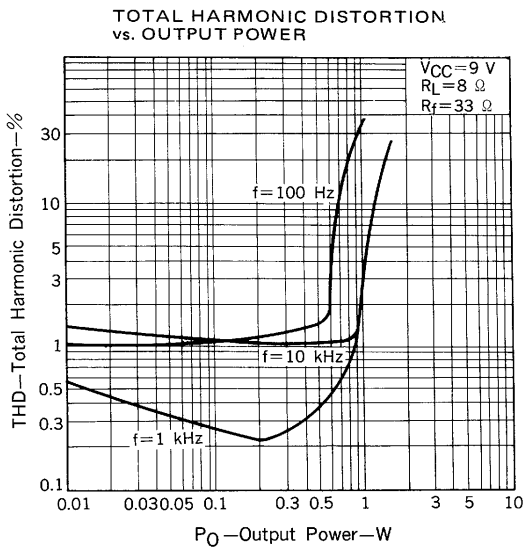
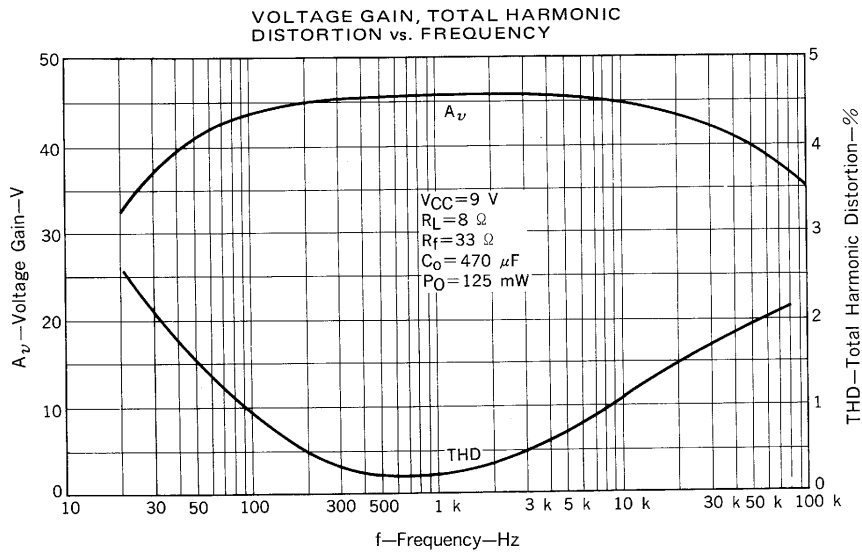

14PIN PLASTIC DIP WITH TAB (300 mil)

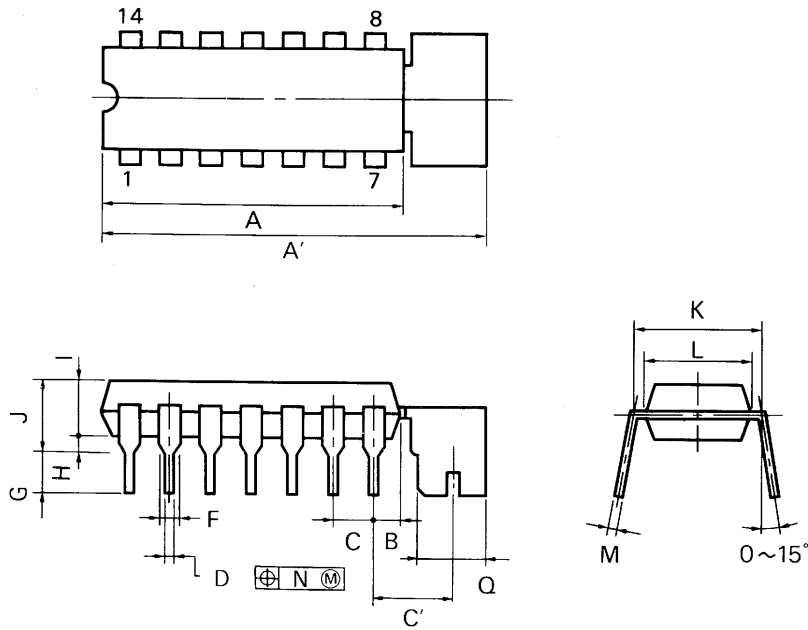

P14CT-100-300B

NOTES

- 1) Each lead centerline is located within 0.25 mm (0.01 inch) of its true position (T.P.) at maximum material condition.
- 2) Item "K" to center of leads when formed parallel.

ITEM	MILLIMETERS	INCHES
A	20.32 MAX.	0.800 MAX.
A'	24.60 MAX.	0.969 MAX.
B	2.54 MAX.	0.100 MAX.
C	2.54 (T.P.)	0.100 (T.P.)
C'	4.74	0.187
D	0.50 ± 0.10	0.020 $\begin{smallmatrix} +0.004 \\ -0.006 \end{smallmatrix}$
F	1.1 MIN.	0.043 MIN.
G	3.4 ± 0.3	0.134 ± 0.012
H	0.51 MIN.	0.020 MIN.
I	4.31 MAX.	0.170 MAX.
J	5.08 MAX.	0.200 MAX.
K	7.62 (T.P.)	0.300 (T.P.)
L	6.4	0.252
M	0.30 $\begin{smallmatrix} +0.10 \\ -0.05 \end{smallmatrix}$	0.012 $\begin{smallmatrix} +0.004 \\ -0.003 \end{smallmatrix}$
N	0.25	0.01
Q	4.40 ± 0.50	0.173 ± 0.020

[MEMO]

No part of this document may be copied or reproduced in any form or by any means without the prior written consent of NEC Corporation. NEC Corporation assumes no responsibility for any errors which may appear in this document.

NEC Corporation does not assume any liability for infringement of patents, copyrights or other intellectual property rights of third parties by or arising from use of a device described herein or any other liability arising from use of such device. No license, either express, implied or otherwise, is granted under any patents, copyrights or other intellectual property rights of NEC Corporation or others.

The devices listed in this document are not suitable for use in the field where very high reliability is required including, but not limited to, aerospace equipment, submarine cables, nuclear reactor control systems and life support systems. If customers intend to use NEC devices for above applications or those intend to use "Standard" quality grade NEC devices for the application not intended by NEC, please contact our sales people in advance.

Application examples recommended by NEC Corporation

Standard: Data processing and office equipment, Communication equipment (terminal, mobile), Test and Measurement equipment, Audio and Video equipment, Other consumer products, Industrial robots, etc.

Special: Automotive and Transportation equipment, Communication equipment (trunk line), Train and Traffic control devices, Burning control systems, antidisaster systems, anticrime systems etc.