

# TB2905HQ

## Class KB High-Efficiency, Low-Frequency Power Amplifier IC Maximum Power: 47 W × 4 Channels

The TB2905HQ is a high-efficiency class KB power amplifier IC developed for car audio applications that incorporates four BTL amplifier channels.

It employs a pure complementary DMOS output stage consisting of P-ch upper and N-ch lower sections, offering a maximum output power (POUT) of 47 W.

Class KB (keyed BTL) amplifiers exhibit less than half the heat generation of comparable class AB solutions under normal operating conditions. Therefore, it is possible to design a smaller heatsink and maintain lower internal temperature in the car audio sets.

Additionally, the TB2905HQ has many built-in functions for car audio, such as standby switching, muting, protective circuits, and self diagnosis.

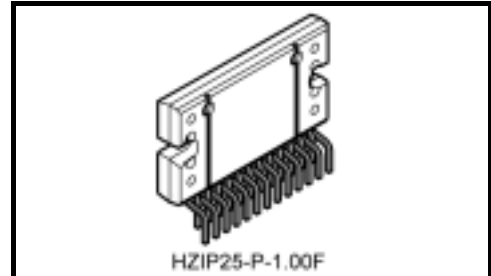

Weight: 7.7 g (typ.)

### Features

- High output power
  - : P<sub>OUT</sub> MAX (1) = 47 W (typ.)  
(V<sub>CC</sub> = 14.4 V, f = 1 kHz, JEITA max, R<sub>L</sub> = 4 Ω)
  - : P<sub>OUT</sub> MAX (2) = 43 W (typ.)  
(V<sub>CC</sub> = 13.7 V, f = 1 kHz, JEITA max, R<sub>L</sub> = 4 Ω)
  - : P<sub>OUT</sub> Pout MAX (3) = 80 W (typ.)  
(V<sub>CC</sub> = 14.4V, f = 1 kHz, JEITA max, R<sub>L</sub> = 2 Ω)
  - : P<sub>OUT</sub> (1) = 29 W (typ.)  
(V<sub>CC</sub> = 14.4 V, f = 1 kHz, THD = 10%, R<sub>L</sub> = 4 Ω)
  - : P<sub>OUT</sub> (2) = 25 W (typ.)  
(V<sub>CC</sub> = 13.2 V, f = 1 kHz, THD = 10%, R<sub>L</sub> = 4 Ω)
  - : P<sub>OUT</sub> (3) = 55 W (typ.)  
(V<sub>CC</sub> = 14.4 V, f = 1 kHz, THD = 10%, R<sub>L</sub> = 2 Ω)
- Low distortion ratio
  - : THD = 0.03% (typ.)  
(V<sub>CC</sub> = 13.2 V, f = 1 kHz, G<sub>V</sub> = 26dB, P<sub>OUT</sub> = 2 W, R<sub>L</sub> = 4 Ω)
- Low noise
  - : V<sub>NO</sub> = 120 μVrms (typ.)  
(V<sub>CC</sub> = 13.2 V, G<sub>V</sub> = 26dB, R<sub>g</sub> = 0 Ω, BW = 20 Hz~20 kHz, R<sub>L</sub> = 4 Ω)
- Built-in standby (pin 4) and muting (pin22) functions
- Built-in offset/clipping detection (pin 25)
- Protective circuits: Thermal shutdown, overvoltage, out to GND, out to VCC, out to out short
- Operating supply voltage: V<sub>CC</sub> (opr) = 9 to 18 V (R<sub>L</sub> = 4 Ω)

Note 1: Some pins of this product are sensitive to electrostatic discharge. When handling this product, ensure that the environment is protected against electrostatic discharge.

Note 2: Install the product correctly. Otherwise, the product or connected equipment may get damaged or degrade.

Note 3: These protective features are intended to temporarily prevent an output short circuit or other abnormal conditions from occurring. Toshiba does not guarantee that they prevent the IC from being damaged. If the product is operating outside any of the guaranteed operating ranges, these protective features may not operate and an output short circuit may result in the IC being damaged.

## Block Diagram

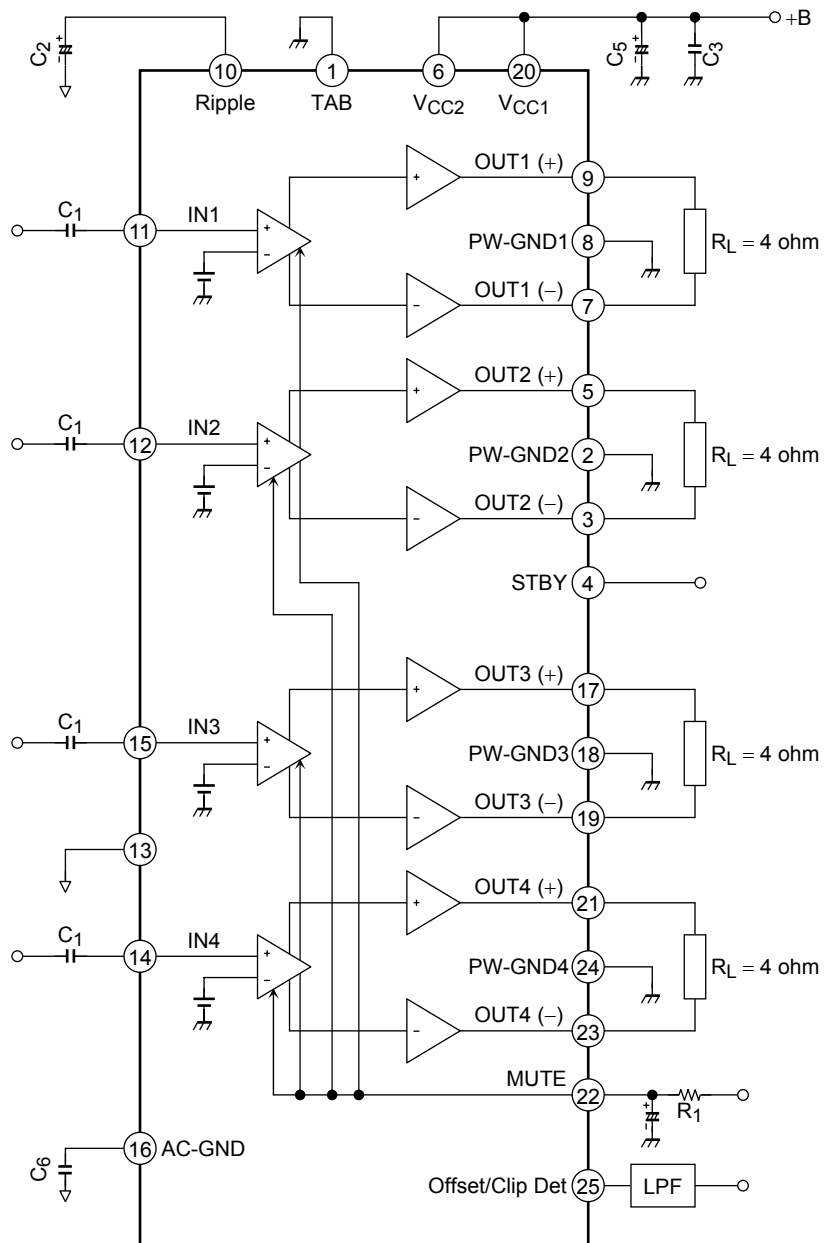

Some of the functional blocks, circuits, or constants in the block diagram may be omitted or simplified for explanatory purpose.

**Operational Description (Each description applies to a single channel)**

**1. Voltage Gain**

The TB2905HQ has no NF (negative feedback) pins. Therefore, the voltage gain ( $G_V$ ) is determined within the IC.

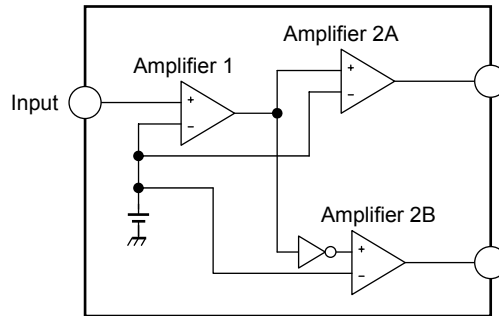

**Figure 1 Amplifier Configuration**

Voltage gain of amplifier 1:  $G_{V1} = 0 \text{ dB}$

Voltage gain of amplifiers 2A and 2B:  $G_{V2} = 20 \text{ dB}$

Voltage gain obtained by BTL connection:  $G_V (\text{BTL}) = 6 \text{ dB}$

Therefore, the total voltage gain is determined by the following expression:

$$G_V = G_{V1} + G_{V2} + G_V (\text{BTL}) = 0 + 20 + 6 = 26 \text{ dB}$$

Although this configuration without an NF pin does not allow the user to adjust voltage gain, it eliminates the need for an NF capacitor, resulting in lower total application cost and smaller mounting space.

**2. Standby Switching Function (Pin 4)**

The TB2905HQ can be powered up or down by controlling the state of pin 4 (standby pin).

The threshold voltage for pin 4 is approximately  $3 V_{BE}$  (typ.). The supply current in standby state is approximately  $2 \mu\text{A}$  (typ.).

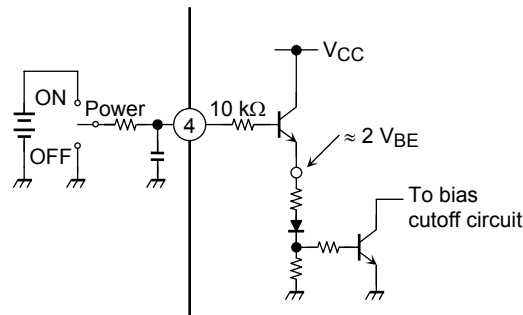

**Figure 2 Driving pin 4 high powers up the TB2905HQ**

**Pin 4 control voltage:  $V_{SB}$**

Stand-by	Power	$V_{SB}$ (V)
ON	OFF	0~0.5
OFF	ON	2.5~6 V

When changing the time constant for pin 4, check the pop noise produced.

**< Advantages of standby switching >**

- (1) The microcontroller can directly turn  $V_{CC}$  on or off without using a switching relay.
- (2) Since the control current is microscopic, a switching relay with small current capacity is satisfactory for switching.

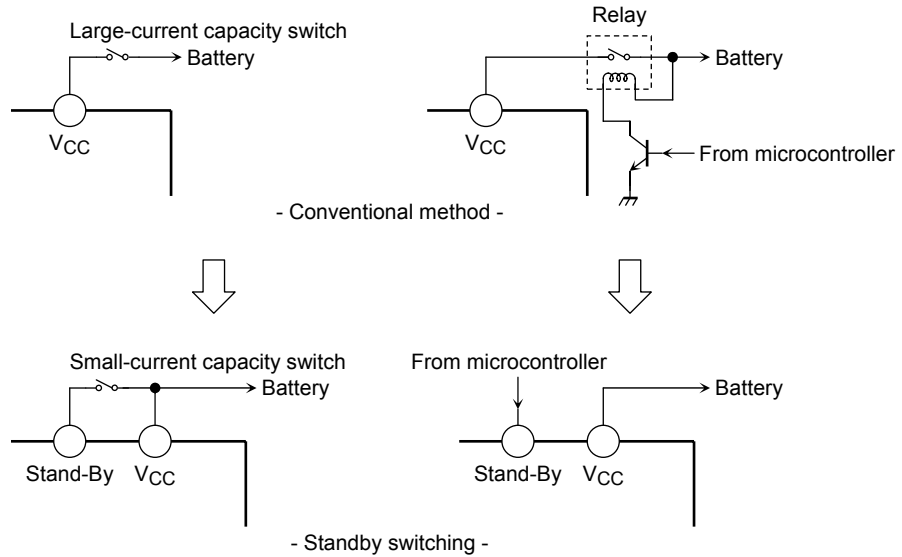

**Figure 3 Standby switching**

**3. Muting Function (Pin 22)**

Driving pin 22 low triggers audio muting.

The time constant for muting is determined from R1 and C4. Select the constants considering the pop noise that is produced when powering the TB2905HQ on/off or turning muting on/off. (See Figures 4 and 5.)

Pin 22 is designed to be controlled at 3.3 V.

The pin functions as a current source switch for the internal muting circuit and is designed so that its discharging current is 200  $\mu$ A. The value of the external pull-up resistor is based on this current.

Example: When changing the control voltage from 3.3 V to 5 V,  $5 \text{ V} / 3.3 \text{ V} \times 47 \text{ k}\Omega = 71 \text{ k}\Omega$

The TB2905HQ internally triggers muting when the voltage is dropped, taking in a current of 200  $\mu$ A. It cannot take in the current if the pull-up resistance is too low. The series resistance (R1) for pin 22 must, therefore, be at least 47 k $\Omega$ .

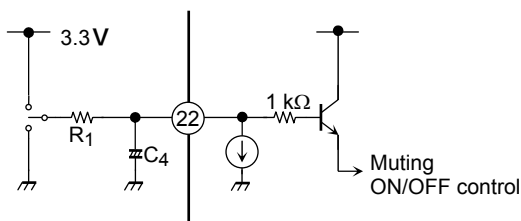

**Figure 4 Muting function**

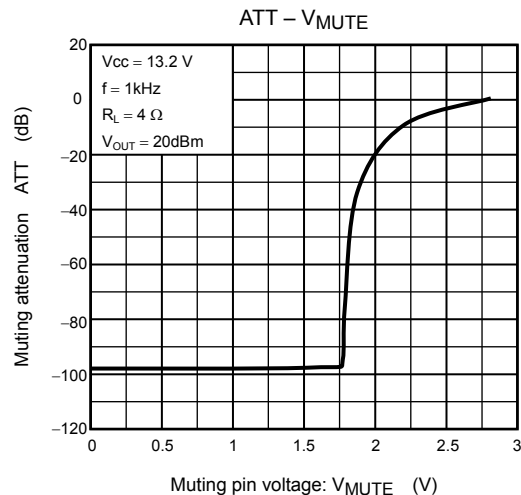

**Figure 5 Muting attenuation – VMUTE (V)**

**4. Offset Detection Function**

Pin 25 can be used to detect an offset voltage that may appear on an output pin due to input capacitor leakage or other reasons.

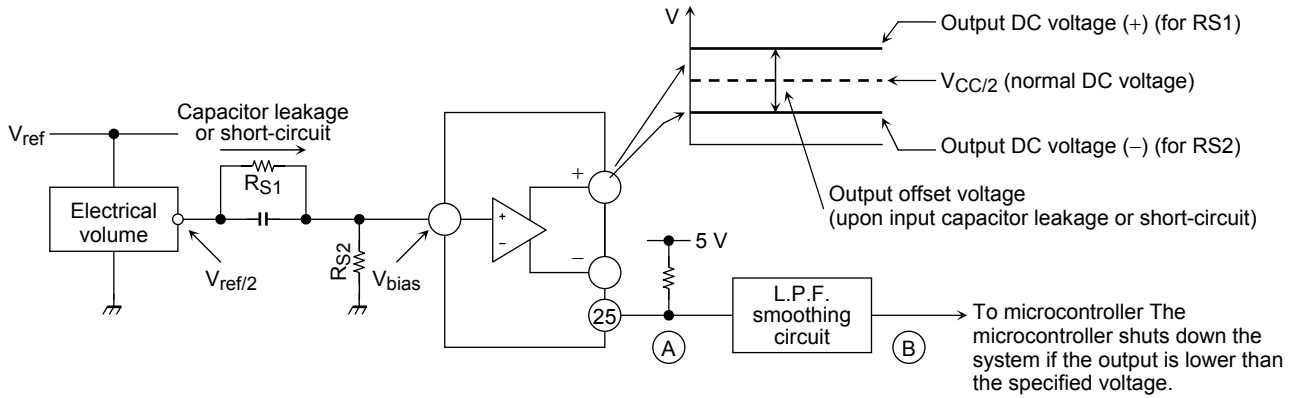

**Figure 6 Example application and detection mechanism**

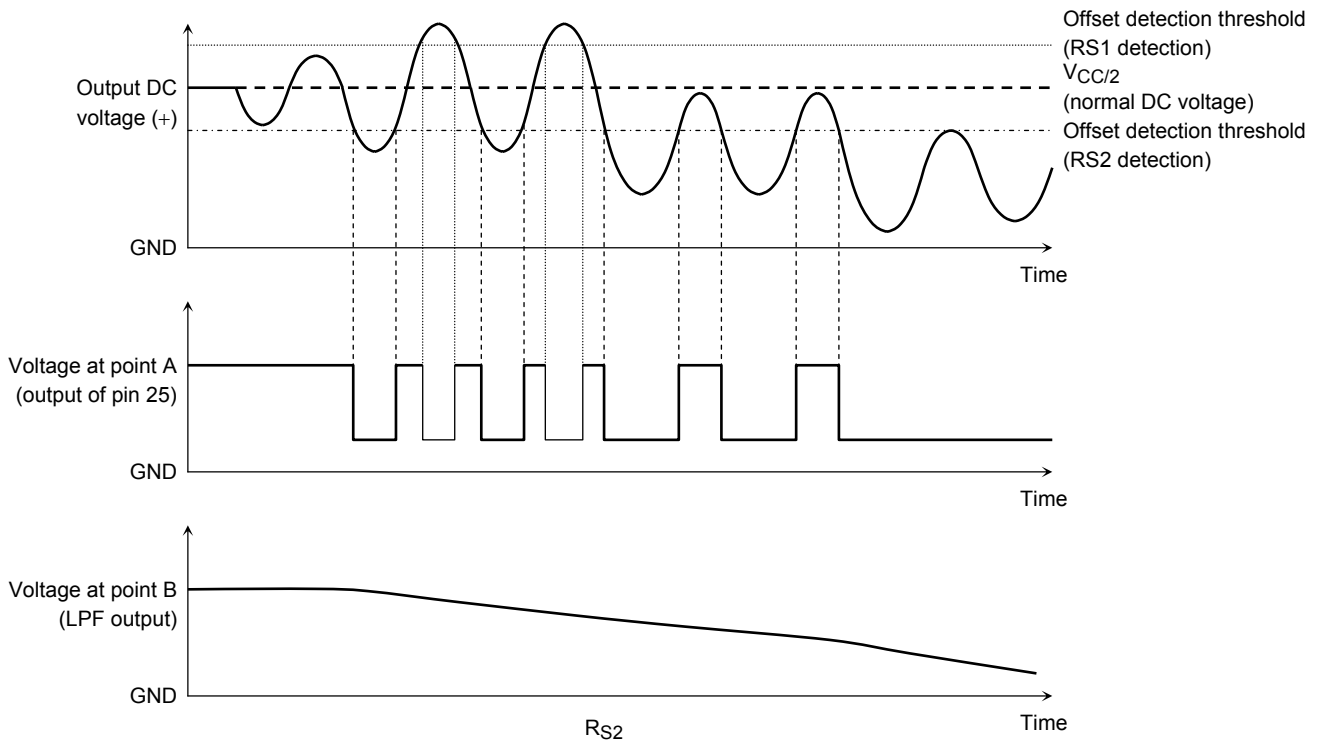

**5. Output Clipping Detection Function (Pin 25)**

Pin 25 has open-collector output (active low) structure, as shown in Figure 7. If the output waveform is clipped, the clipping detection circuit in the IC activates and turns the Q1 NPN transistor on.

The microcontroller can use this signal to control the volume and tone control circuits, thus improving sound quality.

Pin 25 should be left open when this function is not used.

(Example application)

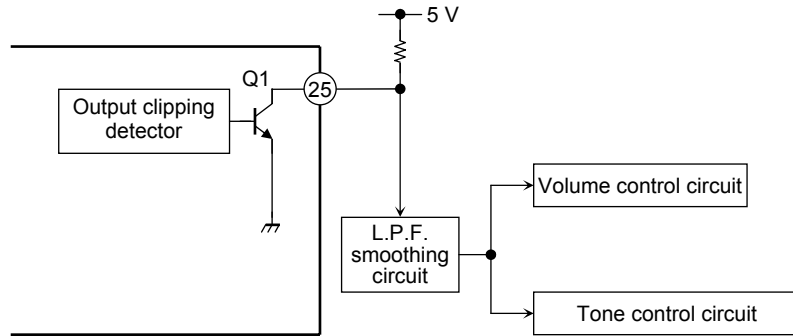

Pin 25: Open-collector output (active low)

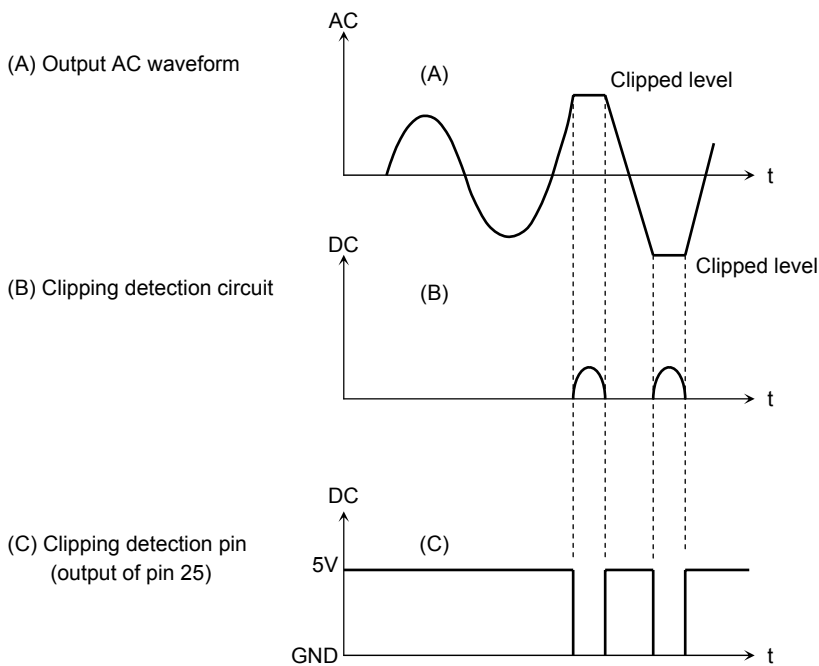

**Figure 8 Clipping detection mechanism**

**6. Pop Noise Suppression**

The TB2905HQ uses AC-GND as a common NF pin for all amplifiers, thus requiring that the ratio of input capacitance C1 to AC-GND capacitance C6 be 1:4.

Powering up the IC initiates the charging of C1 and C6. If the IC is turned off before the charging of C1 and C6 completes, the input DC balance becomes unbalanced, causing a pop noise to be produced.

To suppress the noise, it is recommended that a longer charging time be used for C2 as well as for C1 and C6. Note that the time which audio output takes to start will be longer, since C2 determines the muting time (the time from when the power is turned on to when audio output starts).

The pop noise which is generated when the muting function is turned on/off will vary according to the time constant for C4.

The greater the capacitance, the lower the pop noise. Note that the time from when the muting control signal is applied to C4 to when the muting function is turned on/off will be longer.

**7. External Component Constants**

Component Name	Recommended Value	Purpose	Effect		Remarks
			Smaller than Recommended Value	Larger than Recommended Value	
C1	0.22 $\mu$ F	To eliminate DC	Cutoff frequency is increased	Cutoff frequency is reduced	Affects the pop noise generated when VCC is turned on
C2	10 $\mu$ F	To reduce ripple	Powering on/off is faster	Powering on/off is slower	
C3	0.1 $\mu$ F	To provide sufficient oscillation margin	Reduces noise and provides sufficient oscillation margin		
C4	1 $\mu$ F	To reduce pop noise	High pop noise Duration until muting function is turned on/off is short	Low pop noise Duration until muting function is turned on/off is long	
C5	3900 $\mu$ F	Ripple filter	Power supply humming and ripple filtering		
C6	1 $\mu$ F	NF for all outputs	Pop noise is suppressed when C1:C6 = 1:4		Affects the pop noise generated when VCC is turned on

**8. Preventive measure against oscillation**

For preventing the oscillation, check that the application circuit and actual load makes no abnormal oscillation under all the necessary condition.

Especially, perform the temperature test to check the oscillation margin since the oscillation margin is varied according to the causes described below,

- 1) Layout of printed board
- 2) Type of Speaker
- 3) Value and kind of the capacitor between the output(+) and output(-)
- 4) Value and kind of the CR filter or the capacitor between each output and GND.

**Maximum Ratings (Ta = 25°C)**

Characteristics	Symbol	Rating	Unit
Peak supply voltage (0.2 s)	V <sub>CC (surge)</sub>	50	V
DC supply voltage	V <sub>CC (DC)</sub>	25	V
Operating supply voltage	V <sub>CC (opr)</sub>	18	V
Output current (peak)	I <sub>O (peak)</sub>	9	A
Power dissipation	P <sub>D (Note 5)</sub>	125	W
Operating temperature	T <sub>opr</sub>	-40~85	°C
Storage temperature	T <sub>stg</sub>	-55~150	°C

Note 5: Package thermal resistance ( $\theta_{JT} = 1^{\circ}\text{C}/\text{W}$ ) (Ta = 25°C, with infinite heat sink)

The absolute maximum ratings of a semiconductor device are a set of specified parameter values which must not be exceeded during operation, even for an instant.

Exposure to conditions beyond those listed above may cause permanent damage to the device or affect device reliability, which could increase potential risks of personal injury due to IC blowup and/or burning.

The equipment manufacturer should design so that no maximum rating value is exceeded with respect to current, voltage, power dissipation, temperature, etc.

Ensuring that the parameter values remain within these specified ranges during device operation will help to ensure that the integrity of the device is not compromised.



## Electrical Characteristics

(unless otherwise specified,  $V_{CC} = 13.2\text{ V}$ ,  $f = 1\text{ kHz}$ ,  $R_L = 4\ \Omega$ ,  $T_a = 25^\circ\text{C}$ )

Characteristics	Symbol	Test Circuit	Test Conditions	Min	Typ.	Max	Unit
Quiescent supply current	$I_{CCQ}$	—	$V_{IN} = 0$	—	200	300	mA
Output power	$P_{OUT\ MAX\ (1)}$	—	$V_{CC} = 14.4\text{ V}$ , max POWER	—	47	—	W
	$P_{OUT\ MAX\ (2)}$	—	$V_{CC} = 13.7\text{ V}$ , max POWER	—	43	—	
	$P_{OUT\ (1)}$	—	$V_{CC} = 14.4\text{ V}$ , THD = 10%	—	29	—	
	$P_{OUT\ (2)}$	—	THD = 10%	23	25	—	
Output power ( $R_L = 2\ \Omega$ )	$P_{OUT\ MAX\ (1)}$	—	$V_{CC} = 14.4\text{ V}$ , max POWER	—	80	—	W
	$P_{OUT\ MAX\ (2)}$	—	$V_{CC} = 13.7\text{ V}$ , max POWER	—	77	—	
	$P_{OUT\ (1)}$	—	$V_{CC} = 14.4\text{ V}$ , THD = 10%	—	55	—	
	$P_{OUT\ (2)}$	—	THD = 10%	42	45	—	
Total harmonics distortion	THD	—	$P_{OUT} = 2\text{ W}$	—	0.03	0.2	%
Voltage gain	$G_V$	—	$V_{OUT} = 0.775\text{ V}_{rms}$	24	26	28	dB
Interchannel voltage gain	$\Delta G_V$	—	$V_{OUT} = 0.775\text{ V}_{rms}$	-1.0	0	1.0	dB
Output noise voltage	$V_{NO\ (1)}$	—	$R_g = 0\ \Omega$ , DIN45405	—	130	—	$\mu\text{V}_{rms}$
	$V_{NO\ (2)}$	—	$R_g = 0\ \Omega$ , BW = 20 Hz~20 kHz	—	120	270	
Ripple rejection ratio	R.R.	—	$f_{rip} = 100\text{ Hz}$ , $R_g = 620\ \Omega$ $V_{rip} = 0.775\text{ V}_{rms}$	50	60	—	dB
Crosstalk	C.T.	—	$R_g = 620\ \Omega$ $V_{OUT} = 0.775\text{ V}_{rms}$	—	70	—	dB
Output offset voltage	$V_{OFFSET}$	—	—	-150	0	150	mV
Input resistance	$R_{IN}$	—	—	—	90	—	k $\Omega$
Standby current	$I_{SB}$	—	Standby state	—	2	10	$\mu\text{A}$
Standby control voltage	$V_{SB\ H}$	—	POWER: ON, clipping detection on pin 25	7.5	—	$V_{CC}$	V
	$V_{SB\ M}$	—	POWER: ON, offset detection on pin 25	2.5	—	6.0	
	$V_{SB\ L}$	—	POWER: OFF	0	—	0.5	
Muting control voltage	$V_M\ H$	—	MUTE: OFF	2.5	—	6.0	V
	$V_M\ L$	—	MUTE: ON, $R_1 = 47\text{ k}\Omega$	0	—	0.5	
Muting attenuation	ATT M	—	MUTE: ON $V_{OUT} = 7.75\text{ V}_{rms} \rightarrow$ Mute: OFF	80	90	—	dB
Offset detection threshold voltage	$V_{off-set}$	—	$R_{pull-up} = 47\text{ k}\Omega$ , $+V = 5.0\text{ V}$ Based on normal output DC voltage	$\pm 1.0$	$\pm 1.5$	$\pm 2.0$	V

**Test Circuit**

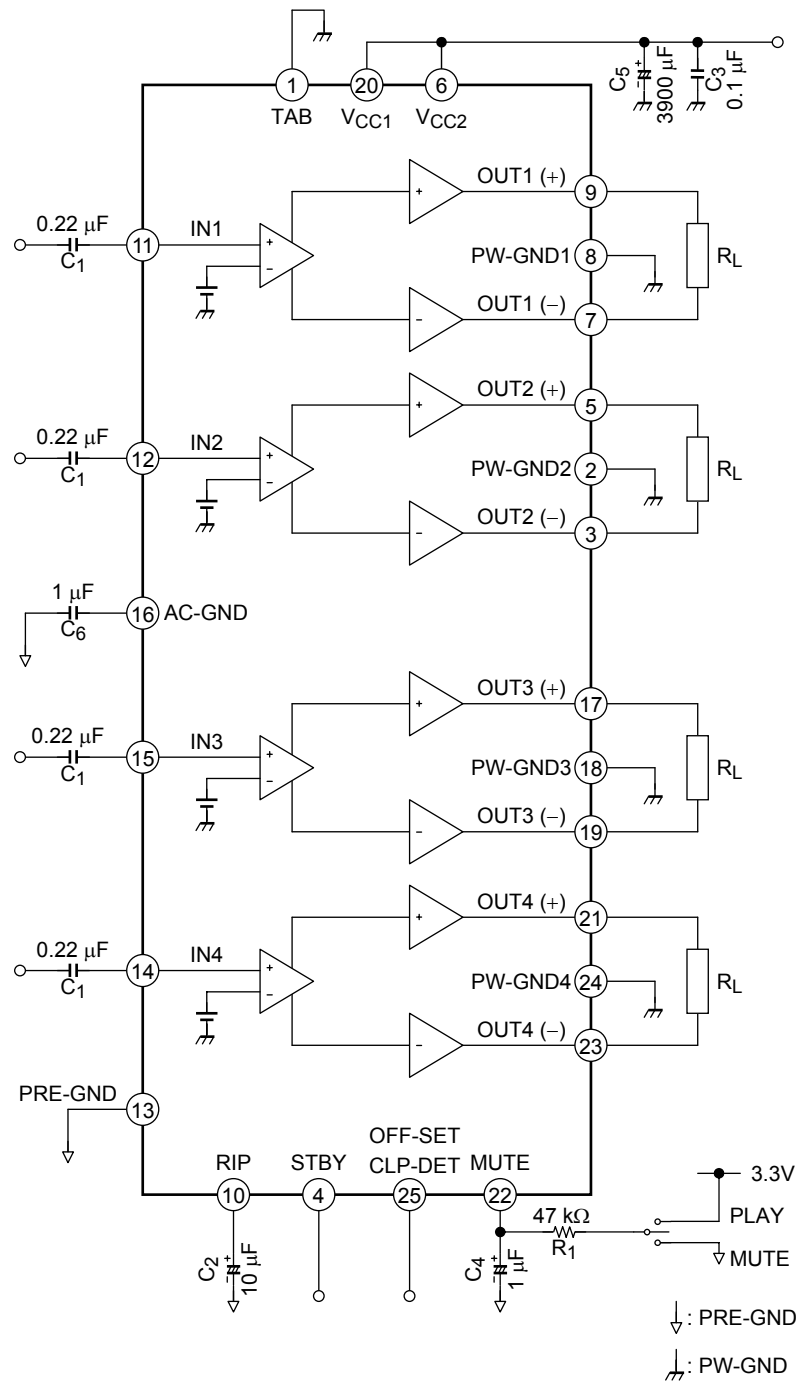

Components in the testing circuit are only used to determine the device's characteristics.  
 Toshiba does not guarantee that those components prevent the application equipment from malfunctioning or failing.

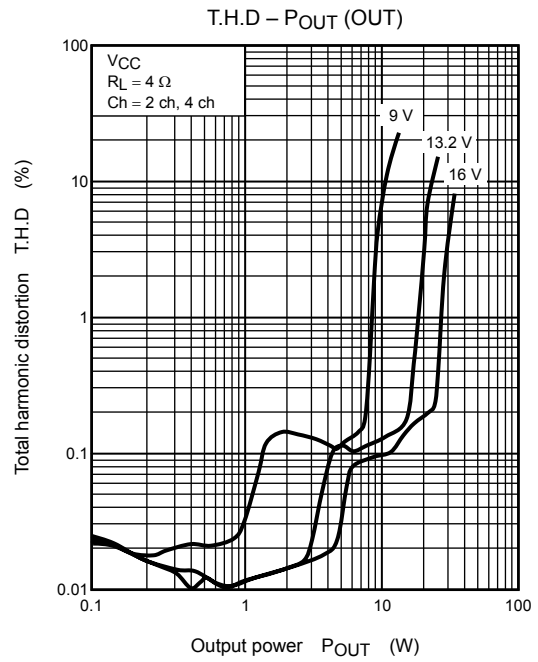
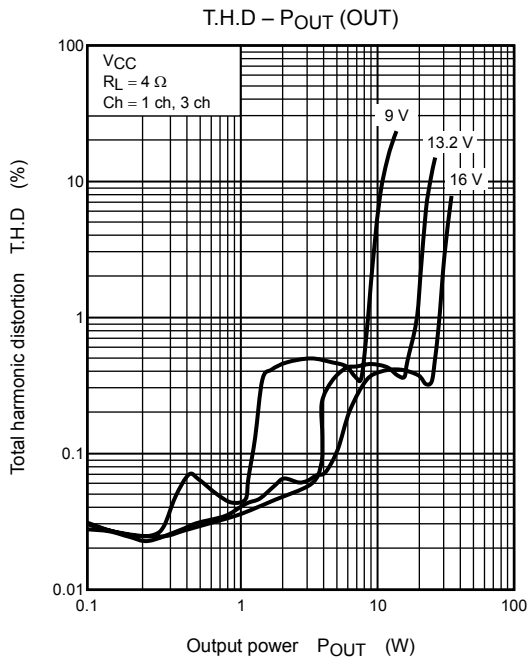
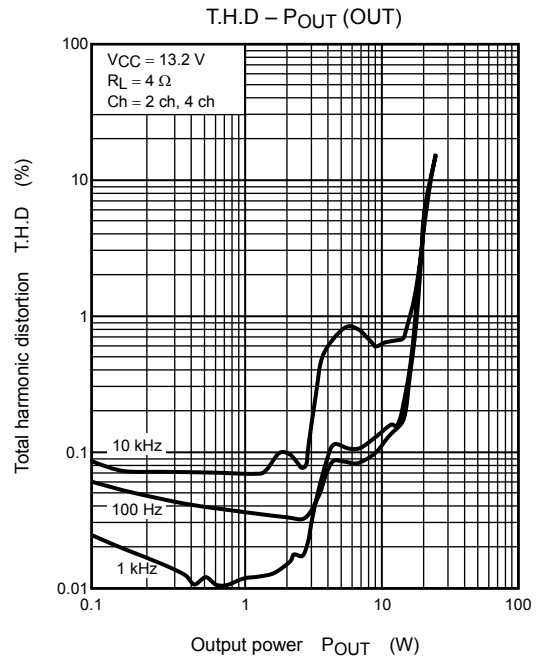
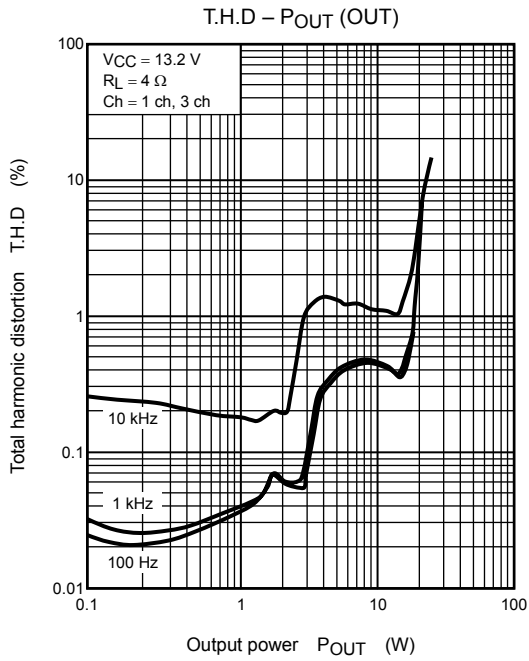

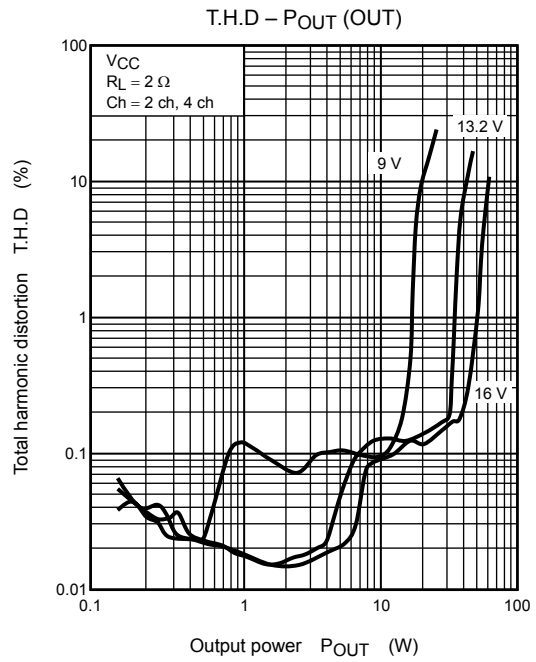
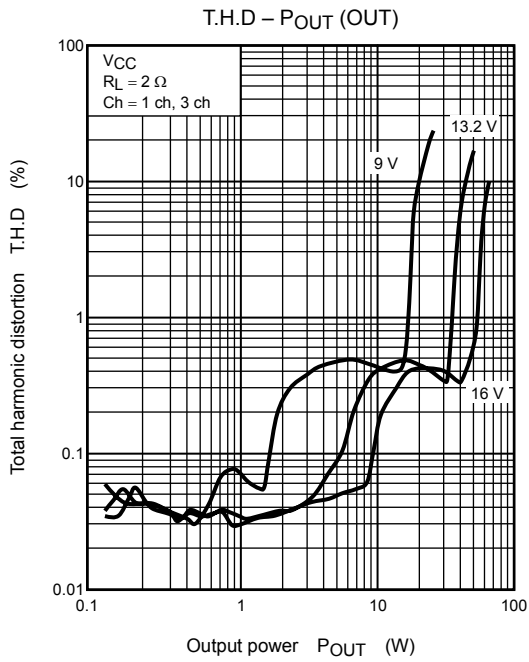
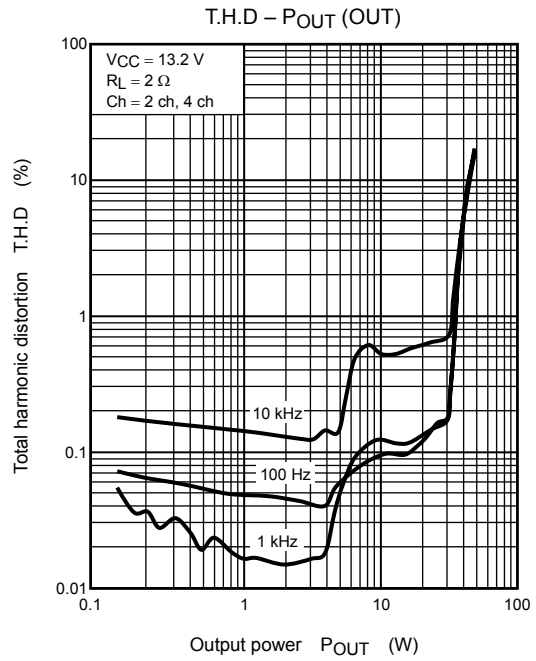
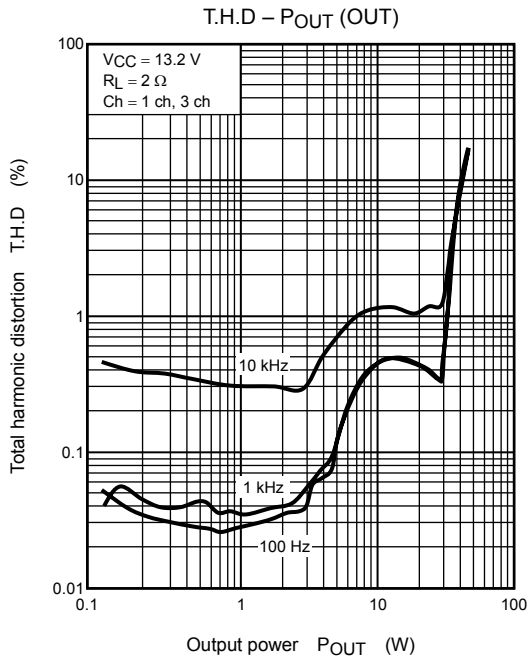

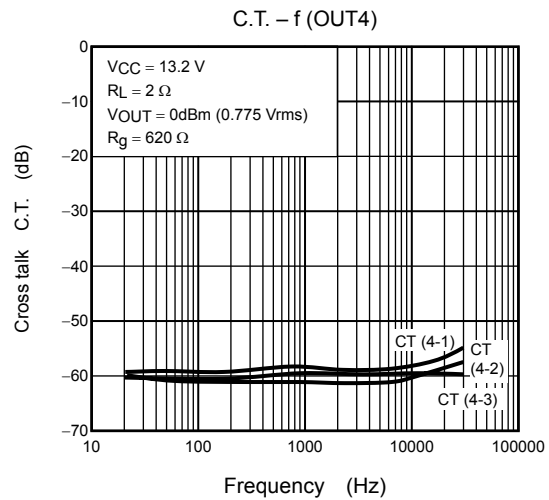
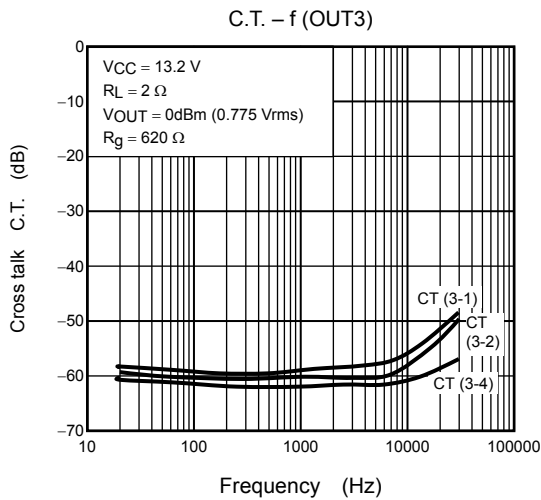
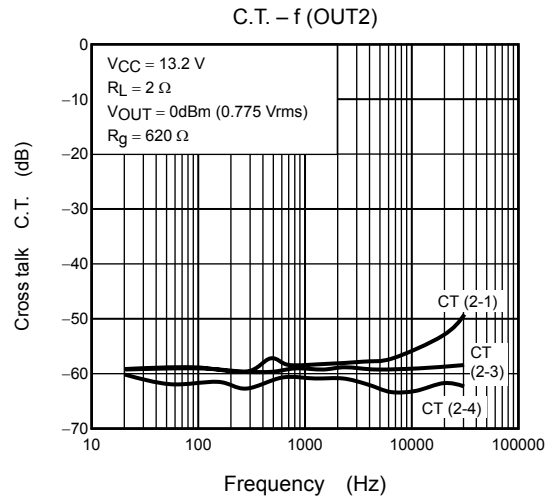
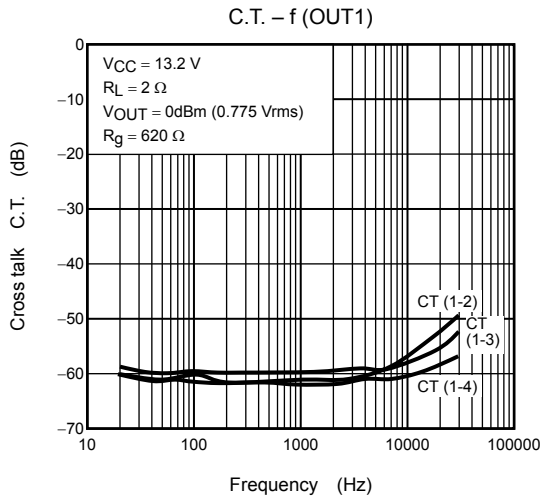
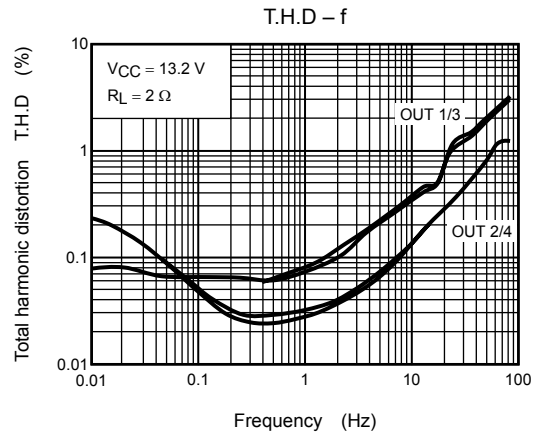
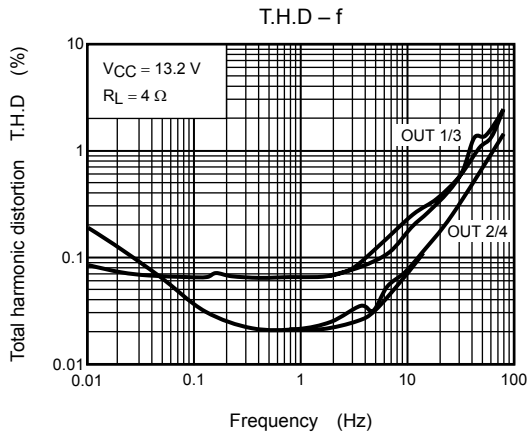

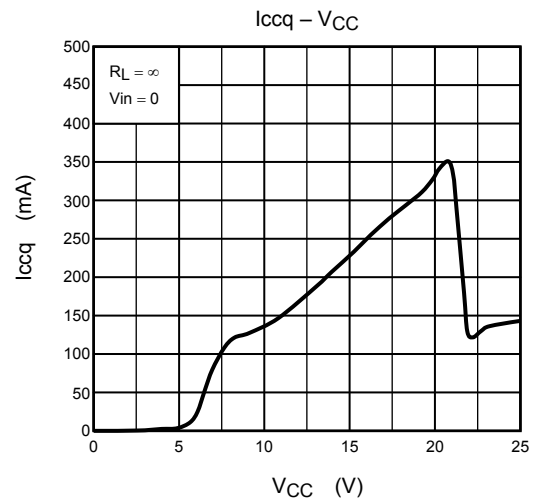
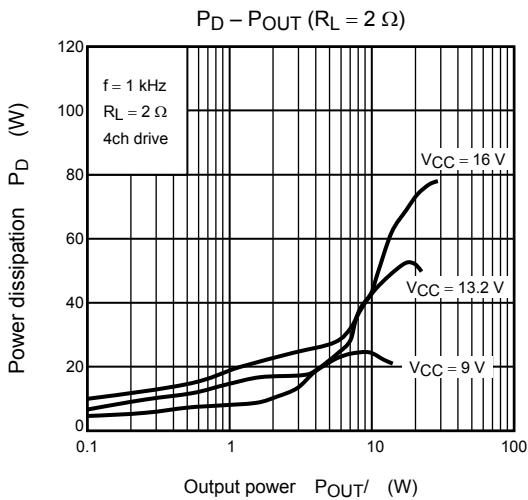
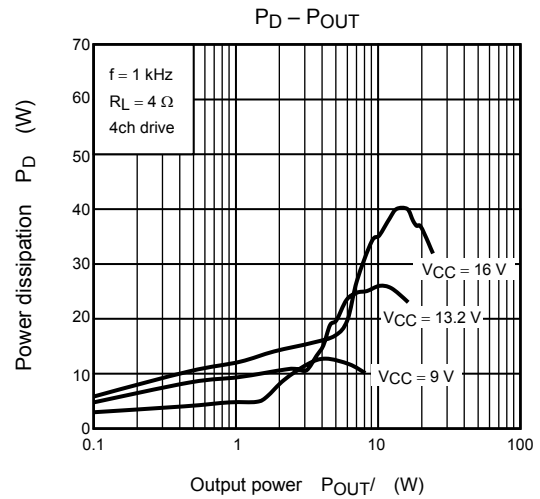
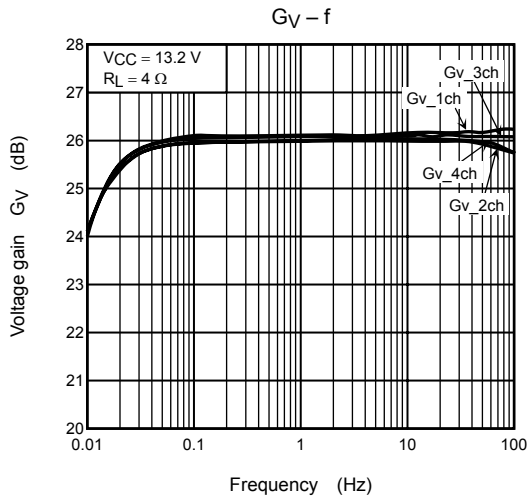
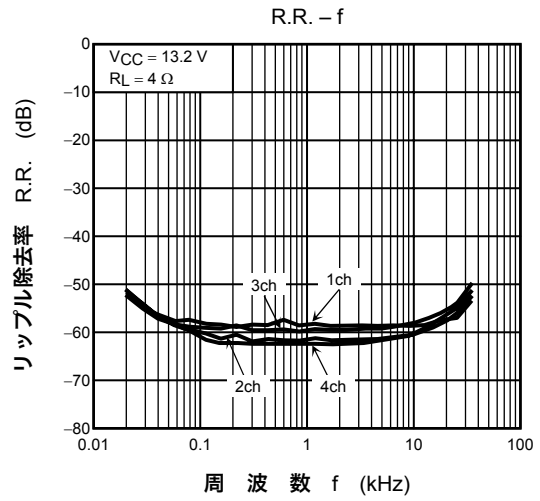
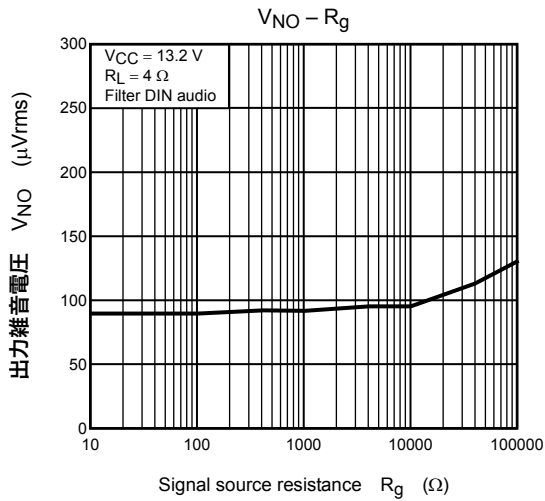

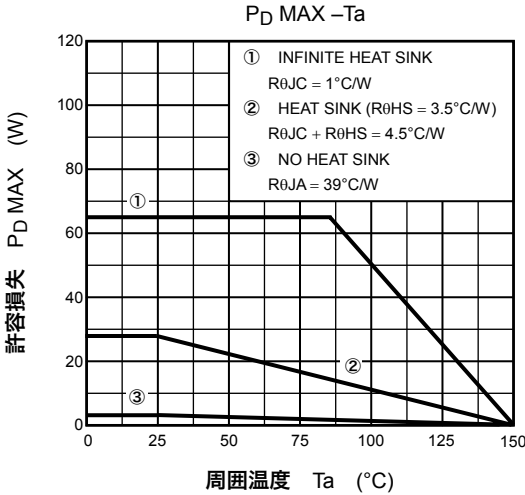

## Package Dimensions

HZIP25-P-1.00F

Unit: mm

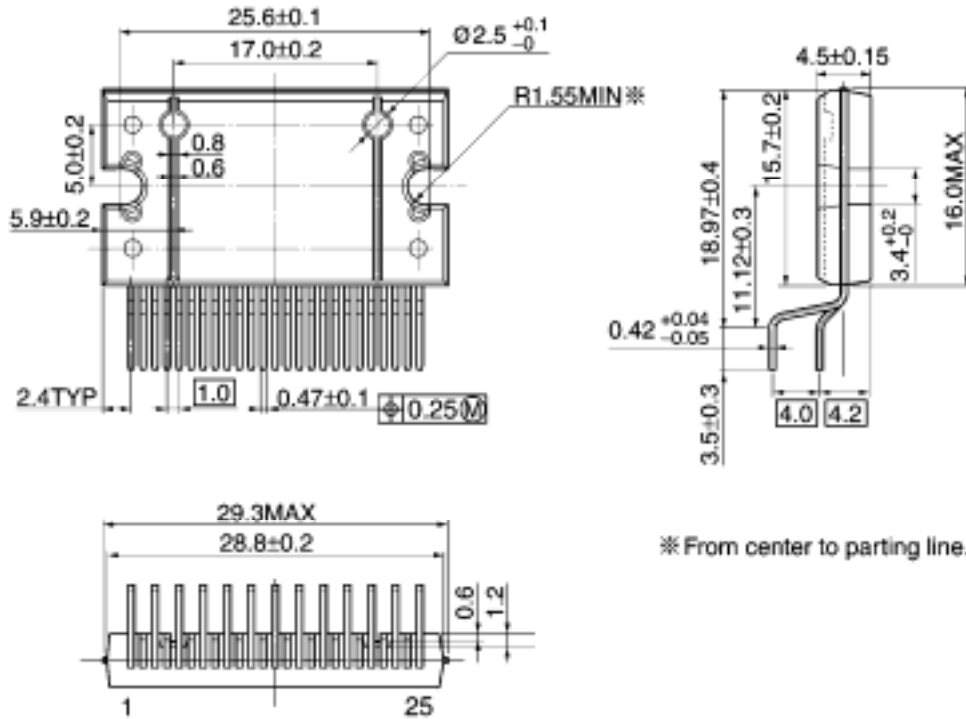

※ From center to parting line.

Weight: 7.7 g (typ.)



About solderability, following conditions were confirmed

- Solderability
  - (1) Use of Sn-63Pb solder Bath
    - solder bath temperature = 230°C
    - dipping time = 5 seconds
    - the number of times = once
    - use of R-type flux
  - (2) Use of Sn-3.0Ag-0.5Cu solder Bath
    - solder bath temperature = 245°C
    - dipping time = 5 seconds
    - the number of times = once
    - use of R-type flux

## RESTRICTIONS ON PRODUCT USE

030619EBF

- The information contained herein is subject to change without notice.
- The information contained herein is presented only as a guide for the applications of our products. No responsibility is assumed by TOSHIBA for any infringements of patents or other rights of the third parties which may result from its use. No license is granted by implication or otherwise under any patent or patent rights of TOSHIBA or others.
- TOSHIBA is continually working to improve the quality and reliability of its products. Nevertheless, semiconductor devices in general can malfunction or fail due to their inherent electrical sensitivity and vulnerability to physical stress. It is the responsibility of the buyer, when utilizing TOSHIBA products, to comply with the standards of safety in making a safe design for the entire system, and to avoid situations in which a malfunction or failure of such TOSHIBA products could cause loss of human life, bodily injury or damage to property.  
In developing your designs, please ensure that TOSHIBA products are used within specified operating ranges as set forth in the most recent TOSHIBA products specifications. Also, please keep in mind the precautions and conditions set forth in the "Handling Guide for Semiconductor Devices," or "TOSHIBA Semiconductor Reliability Handbook" etc..
- The TOSHIBA products listed in this document are intended for usage in general electronics applications (computer, personal equipment, office equipment, measuring equipment, industrial robotics, domestic appliances, etc.). These TOSHIBA products are neither intended nor warranted for usage in equipment that requires extraordinarily high quality and/or reliability or a malfunction or failure of which may cause loss of human life or bodily injury ("Unintended Usage"). Unintended Usage include atomic energy control instruments, airplane or spaceship instruments, transportation instruments, traffic signal instruments, combustion control instruments, medical instruments, all types of safety devices, etc.. Unintended Usage of TOSHIBA products listed in this document shall be made at the customer's own risk.
- The products described in this document are subject to the foreign exchange and foreign trade laws.
- TOSHIBA products should not be embedded to the downstream products which are prohibited to be produced and sold, under any law and regulations.
- This product generates heat during normal operation. However, substandard performance or malfunction may cause the product and its peripherals to reach abnormally high temperatures.  
The product is often the final stage (the external output stage) of a circuit. Substandard performance or malfunction of the destination device to which the circuit supplies output may cause damage to the circuit or to the product.