

TOSHIBA BIPOLAR LINEAR INTEGRATED CIRCUIT SILICON MONOLITHIC

TA8403K

POWER AMPLIFIER FOR DRIVING A DEFLECTION CIRCUIT OF A COLOR TELEVISION

TA8403K is a power amplifier for driving a vertical deflection circuit of a small and medium screen size color television. TA8403K is available for constructing a stable deflection circuit with small number parts in an application with a single chip signal processing IC TA8879N.

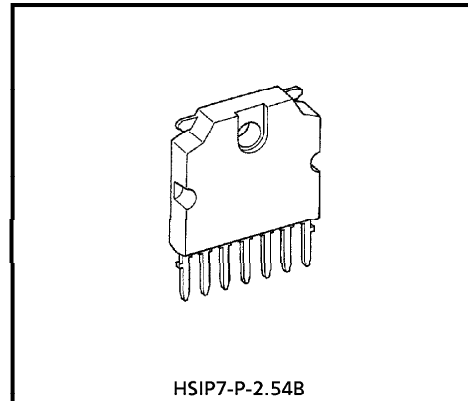

Weight : 0.7g (Typ.)

FEATURES

- Large output current : 1.8Ap-p (Max.)
- Small power dissipation with a pump-up circuit
- Small number external parts

BLOCK DIAGRAM

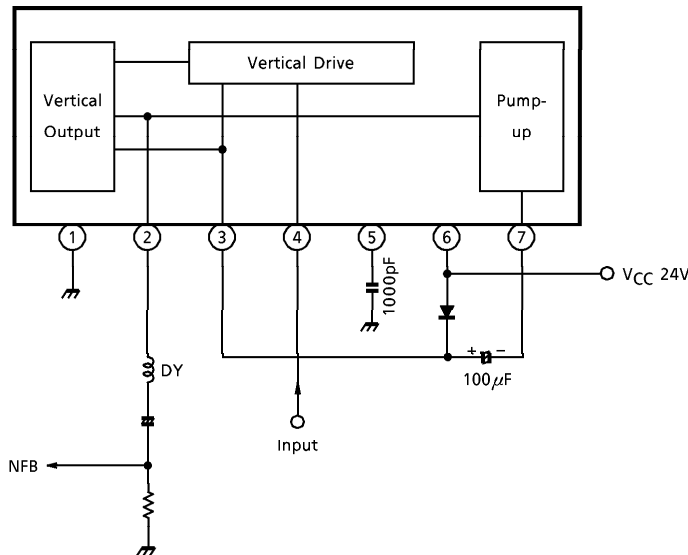

TERMINAL NAME

1. GND
2. Vertical Output
3. Pump-up Power Supply
4. Input
5. Phase Compensation
6. Power Supply
7. Pump-up Output

961001EBA2

● TOSHIBA is continually working to improve the quality and the reliability of its products. Nevertheless, semiconductor devices in general can malfunction or fail due to their inherent electrical sensitivity and vulnerability to physical stress. It is the responsibility of the buyer, when utilizing TOSHIBA products, to observe standards of safety, and to avoid situations in which a malfunction or failure of a TOSHIBA product could cause loss of human life, bodily injury or damage to property. In developing your designs, please ensure that TOSHIBA products are used within specified operating ranges as set forth in the most recent products specifications. Also, please keep in mind the precautions and conditions set forth in the TOSHIBA Semiconductor Reliability Handbook.

● The products described in this document are subject to foreign exchange and foreign trade control laws.

● The information contained herein is presented only as a guide for the applications of our products. No responsibility is assumed by TOSHIBA CORPORATION for any infringements of intellectual property or other rights of the third parties which may result from its use. No license is granted by implication or otherwise under any intellectual property or other rights of TOSHIBA CORPORATION or others.

● The information contained herein is subject to change without notice.

MAXIMUM RATINGS (Ta = 25°C)

CHARACTERISTIC	SYMBOL	RATING	UNIT
Power Supply Voltage	V _{CC}	30	V
Pump-up Power Supply Voltage	V _{Vt}	60	V
Terminal Voltage	E _{in}	GND - 0.3 ~ V _{Vt} + 0.3	V
Input Signal Voltage	e _{in}	0~1.2	V
Power Dissipation	P _D	15 (Note)	W
Operating Temperature	T _{opr}	- 20~85	°C
Storage Temperature	T _{stg}	- 55~150	°C

(Note) Using an infinite heat sink

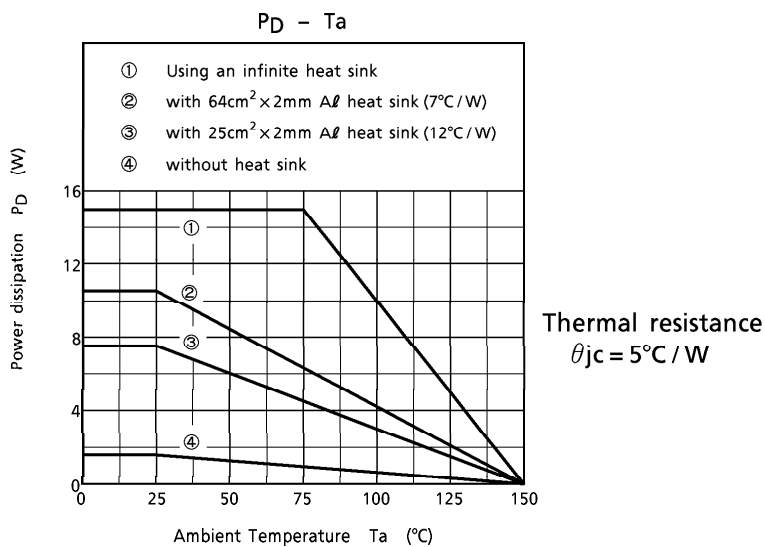

RECOMMENDED OPERATING CONDITION

CHARACTERISTIC	SYMBOL	MIN.	TYP.	MAX.	UNIT
Power Supply	V _{CC}	—	24	27	V
Deflection Output Current	I _{2p-p}	—	—	1.8	A _{p-p}

ELECTRICAL CHARACTERISTICS (Ta = 25°C, VCC = 24V)

CHARACTERISTIC	SYMBOL	TEST CIR-CUIT	TEST CONDITION	MIN.	TYP.	MAX.	UNIT
Saturation Voltage of the Vertical Output Transistor (1)	$V_{V(sat)1}$	1	(Note 1)	0.3	0.5	1.0	V
Saturation Voltage of the Vertical Output Transistor (2)	$V_{V(sat)2}$	1	(Note 2)	1.0	1.8	3.6	V
Saturation Voltage of the Pump-up Output Transistor (1)	$V_{P(sat)1}$	1	(Note 3)	1.0	2.0	3.0	V
Saturation Voltage of the Pump-up Output Transistor (2)	$V_{P(sat)2}$	1	(Note 4)	0.3	0.8	1.6	V
Output Current with no input	I_b	1	(Note 5)	10.0	15.0	30.0	mA
Center Output Voltage	V_{center}			10.0	12.0	14.0	V

(Note 1) SW₁ : ON, SW₂ : C, SW₃ : ON, SW₄ : B, SW₅ : A, SW₆ : A
Measure the voltage of pin2.

(Note 2) SW₁ : ON, SW₂ : C, SW₃ : ON, SW₄ : A, SW₅ : A, SW₆ : B
Measure the voltage of pin2, V₂. $V_{V(sat)2} = V_{CC} - V_2$

(Note 3) SW₁ : ON, SW₂ : B, SW₃ : OFF, SW₄ : A, SW₅ : C, SW₆ : A
Measure the voltage of pin7, V₇. $V_{P(sat)1} = V_{CC} - V_7$

(Note 4) SW₁ : OFF, SW₂ : C, SW₃ : OFF, SW₄ : A, SW₅ : B, SW₆ : B
Measure the voltage of pin7.

(Note 5) SW₁ : ON, SW₂ : A, SW₃ : ON, SW₄ : C, SW₅ : A, SW₆ : B
Measure the sink current into pin3.
Measure the voltage of pin2.

(Note 6) TA8403K is checked its output wave form in a real operating circuit.

OUTLINE DRAWING
HSIP7-P-2.54B

Unit : mm

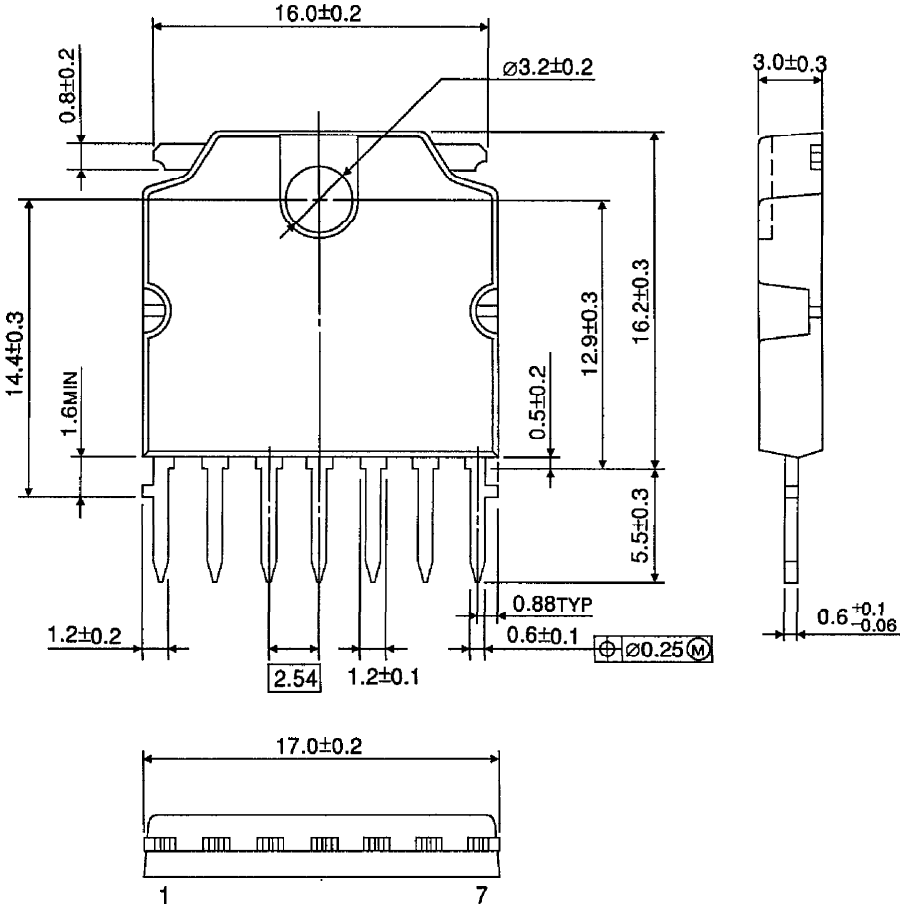

Weight : 0.7g (Typ.)