

**MULTISTANDARD VIDEO AND SOUND IF SYSTEM
WITH AUDIO AND VIDEO SWITCHES**

- VIDEO PLL DEMODULATION
- SOUND PLL DEMODULATION
- NEGATIVE MODULATION
- AGC FOR NEGATIVE MODULATION
- AUDIO SWITCH
- DC VOLUME CONTROL
- VIDEO SWITCH



DESCRIPTION

The STV8223B is a picture and sound IF processor for multistandard application with very few external components and adjustments.

It provides the audio and video switches for one SCART plug application.

PIN CONNECTIONS

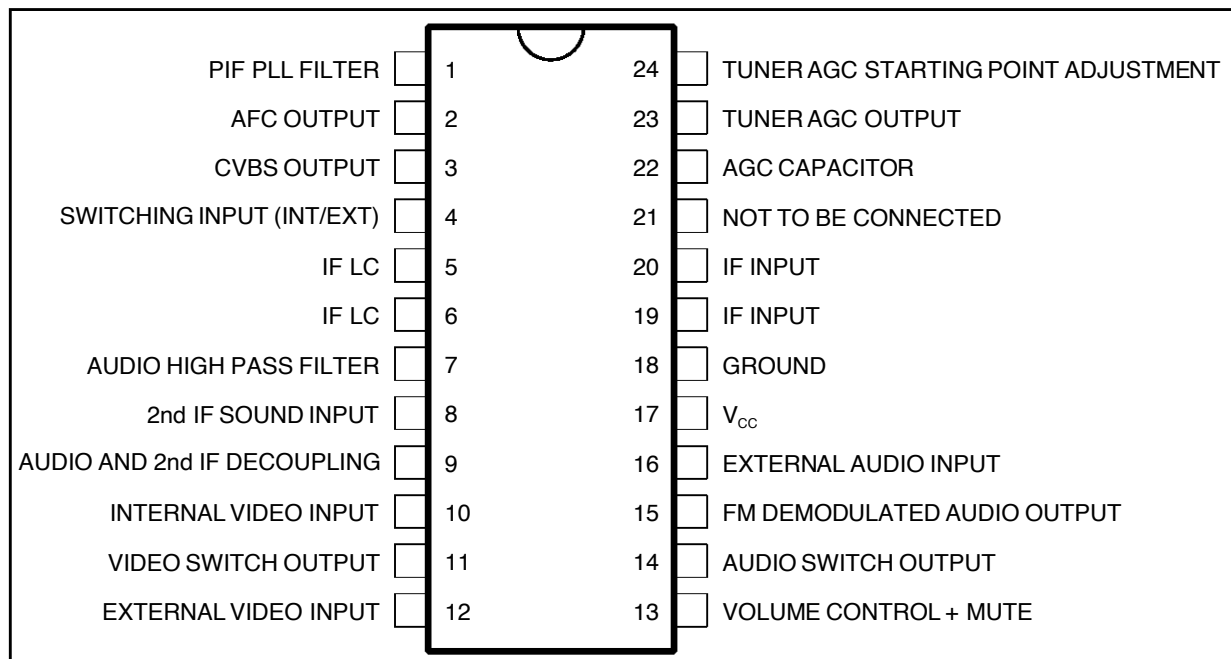

BLOCK DIAGRAM

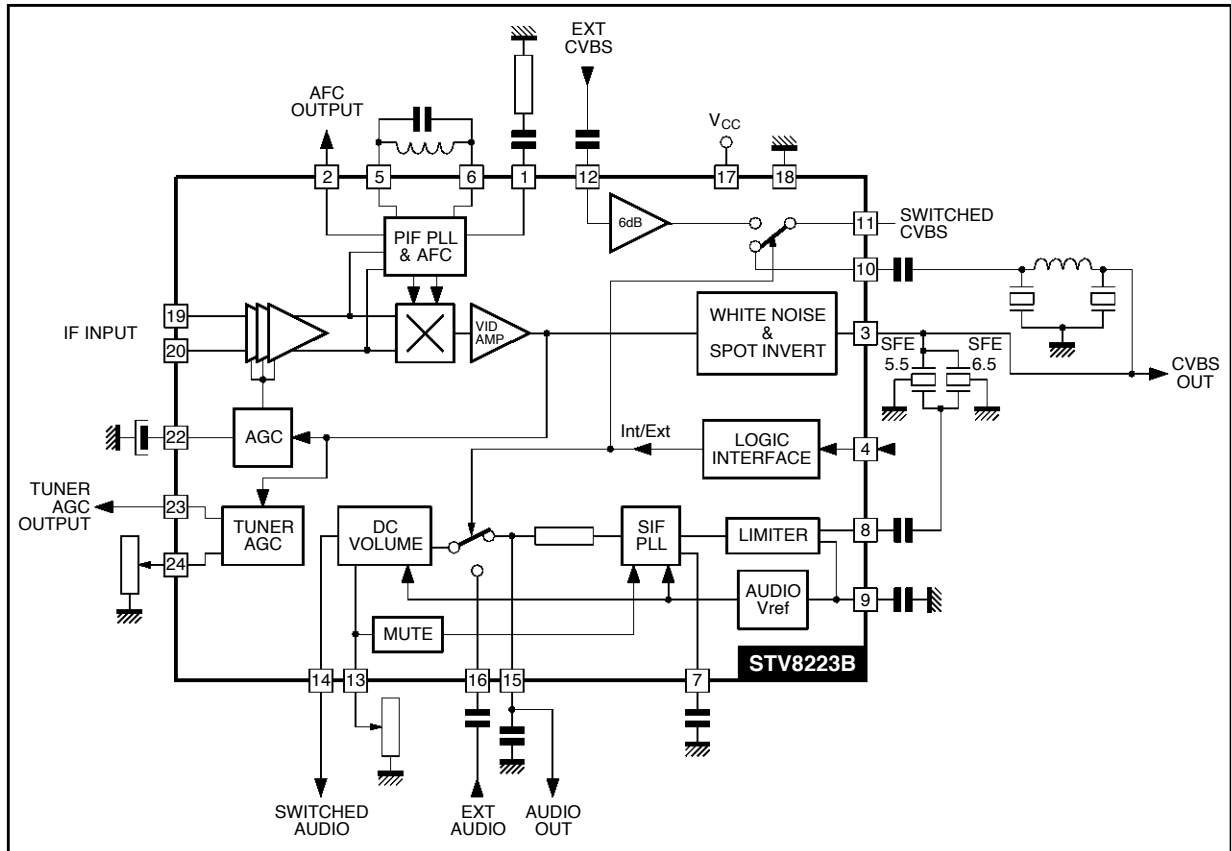

8223B-02.EPS

ABSOLUTE MAXIMUM RATINGS

Symbol	Parameter	Value	Unit
V _S	Supply Voltage	13.5	V
V _X	Tuner AGC Voltage	V _{CC}	V
T _{stg}	Storage Temperature	-40, +150	°C
T _{oper}	Operating Temperature	0, +70	°C

8223B-01.TBL

THERMAL DATA

Symbol	Parameter	Value	Unit
R _{th(j-a)}	Junction-ambient Thermal Resistance	Max. 75	°C/W

8223B-02.TBL

ELECTRICAL CHARACTERISTICS

($T_{amb} = 25^{\circ}C$, $V_{CC} = 9V$, IF input = $10mV_{RMS}$ sync level at B/G,
 Video modulation DSB, $D = 90\%$ at B/G, $f_{PC} = 38.9MHz$, $f_{SC} = 33.4MHz$,
 Video BW = 5MHz, Sound carrier input : 5.5MHz, $10mV_{RMS}$, $f_M = 1kHz$, Audio BW = 20kHz, $\Delta f = \pm 50kHz$,
 Volume attenuation = 0dB, unless otherwise specified)

Symbol	Parameter	Test Conditions	Min.	Typ.	Max.	Unit
--------	-----------	-----------------	------	------	------	------

SUPPLY

V_{CC}	Supply Voltage		8	9	12.6	V
I_{CC}	Supply Current	I_{17} , $V_{CC} = 9V$		70	95	mA

IF AMPLIFIER

V_{19-20}	Input Sensitivity (RMS)	-3dB Video at Output		70		μV_{RMS}
R_{19-20}	Differential Input Resistance			2		k Ω
C_{19-20}	Differential Input Capacitance			2		pF
Gr	Gain Control Range			68		dB
	Max Input Signal	+1dB Video at Output		180		mV_{RMS}

SYNCHRONOUS VIDEO DEMODULATOR

DF _{PC}	Vision Carrier Capture		-1.4		1.6	MHz
------------------	------------------------	--	------	--	-----	-----

AFC

S2	AFC Slope	See Figure 21		0.2		$\mu A/kHz$
----	-----------	---------------	--	-----	--	-------------

DEMODULATED VIDEO OUTPUT (Pin 3)

V_{A3}	Amplitude	Top Sync to White	2	2.3	2.6	V_{PP}
BG vs L	Amplitude Difference				10	%
V_{S3}	Top Sync Level	B/G	1.6	1.9	2.2	V
	Zero Carrier Level	B/G		4.4		V
BW	Bandwidth	-3dB Video Signal	7	9		MHz
Dg	Differential Gain			6	8	%
Dp	Differential Phase			3	6	Degree
Vr3c	Residual Carrier Signal (RMS Value)			1	10	mV
Vr3h	Residual 2nd Harmonic (RMS Value)			1	10	mV
I_3	Internal Bias of Emitter Follower		3	5		mA
S/N	Signal to Noise Ratio	Note 1 - Weighted CCIR-567	56	61		dB
	Intermodulation 1.07MHz	Note 2		52		dB
V_{WTH}	White Noise Threshold Voltage			4.85		V
V_{WIL}	White Noise Insertion Level			3.6		V
V_{BTH}	Black Noise Threshold Voltage			1.3		V
V_{BIL}	Black Noise Insertion Level			2.5		V

AGC CIRCUIT

I_{22CBG}	Charging Current		550	950	1300	μA
I_{22DBG}	Discharge Current		12	20	28	μA
C/D	Charging/Discharging Ratio			45		

TUNER AGC

I_{23}	Maximum Sunked Current		1.5	2	2.5	mA
S23	Current Slope	$R_{24} = 5k\Omega$	100	170	230	$\mu A/dB$
I_{23+}	Maximum Tuner Plus Sunked Current	Note 3		40		mA

Notes : 1. $\frac{S}{N} = 20 \log 10 \frac{V_{out\ black\ white}}{V_N (mV_{RMS})}$ at BW = 5MHz

- Video carrier relative level = 0dB, Chroma subcarrier level = -3.2dB, Sound carrier relative level = -20dB. AGC voltage (Pin 22) is adjusted to get 1V_{PP} signal on output (Pin 3).
- Additional sunked current for large increasing steps of input signal when :
 - Voltage Pin 22 > starting point defined Pin 24.
 - Output signal (Pin 3) saturated ($V_3 < V_{BTH}$ in BG mode).

ELECTRICAL CHARACTERISTICS (continued)

($T_{amb} = 25^{\circ}C$, $V_{CC} = 9V$, IF input = $10mV_{RMS}$ sync level at B/G,
 Video modulation DSB, $D = 90\%$ at B/G, $f_{PC} = 38.9MHz$, $f_{SC} = 33.4MHz$,
 Video BW = 5MHz, Sound carrier input : 5.5MHz, $10mV_{RMS}$, $f_M = 1kHz$, Audio BW = 20kHz, $\Delta f = \pm 50kHz$,
 Volume attenuation = 0dB, unless otherwise specified)

Symbol	Parameter	Test Conditions	Min.	Typ.	Max.	Unit
--------	-----------	-----------------	------	------	------	------

FM SOUND DEMODULATION

V_{8S}	Input Sensitivity			150		μV_{RMS}
R_8	Limiter Input Resistance			600		Ω
	DC Voltage (Pin 8)			4.2		V
AMR	Amplitude Modulation Rejection	Note 4	50	61		dB
SVR	Supply Voltage Rejection Ratio	Ripple signal : 100Hz, 0.5V _{PP}	28	33		dB
V_{15}	Detected Audio Output Signal		0.85	1.1	1.4	V_{RMS}
THD	Total Harmonic Distortion			0.2	1	%
R_{15}	Internal Deemphasis Resistor		600	750	900	Ω
S/N	Signal to Noise Ratio	See Note 5, Weighted CCIR 468-4, (quasi peak level) input Pin 8	55	60		dB
	Black Picture (sync only)	Measurement between IF input (Pins 19-20) and audio output (Pin 15) SAW : K2955 BPF : SFE5.5MB	47	52		dB
	White Picture		46	50		dB
	250kHz Square Wave		47	52		dB

VOLUME CONTROL

V_C Range	Control Range	See Figure 22	72	77		dB
-------------	---------------	---------------	----	----	--	----

AUDIO SWITCH

R_{16}	Input Resistance		55	70	85	k Ω
CR _{tk}	Crosstalk		70	80		dB
En	Output Noise Level (Pin 14)	Weighted CCIR 468-4, $V_{13} = 0.5V$ (quasi peak level)		70		μV
EXTHD	THD on External Signal (Pin 14)	$V_{IN} = 2V_{RMS}$, Attenuation = 0dB		0.1	0.3	%
	Audio Reference Voltage (Pin 9)			4.5		V

VIDEO SWITCH

V_{DC12}	DC Input Level	No signal	1.6	1.9	2.2	V
V_{S12}	Top Sync. Clamp Level			1.8		V
V_{11}	DC Output Level	No signal	1.7	2	2.3	V
V_{S11}	Top Sync. Clamp Level			1.5		V
	Crosstalk			55		dB
GEX	Gain from Ext. Input to Output		5.5	6	6.5	dB
	Output Swing		4	5		V
I_{12}	Input Current	$V_{12} = V_{DC12} = 1.5V$		1	5	μA
VBW	Bandwidth	$V_{IN} = 1V_{PP}$		15		MHz
G_{IN}	Gain from Int. Input to Output		-0.5	0	+0.5	dB

MUTE (Pin 13)

V_{TH13}	Threshold Voltage Pin 13		0.2	0.3	0.4	V
------------	--------------------------	--	-----	-----	-----	---

CONTROL INPUT

	Negative Modulation	Video : External - Audio : External	7.2			V
	Negative Modulation	Video : Internal - Audio : Internal			1.8	V

Notes : 4. $AMR = 20 \log \frac{V_{15}(mV_{RMS})}{V_{AM}}$ (dB) where V_{AM} = output amplitude in AM for $f_M = 1kHz$ and $m = 30\%$

5. $\frac{S}{N} = 20 \log \frac{V_{15}(mV_{RMS})}{V_N(mV_{RMS})}$ (dB)

INPUT/OUTPUT PIN CONFIGURATION

Figure 1 : PIF PLL Filter

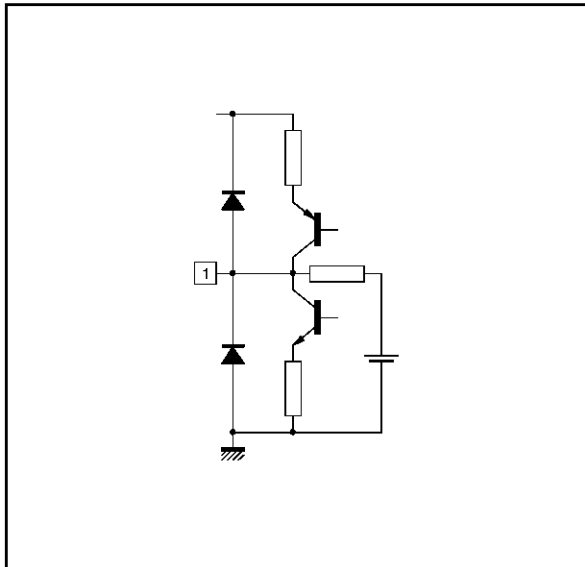

8223B-03.EPS

Figure 2 : AFC Output

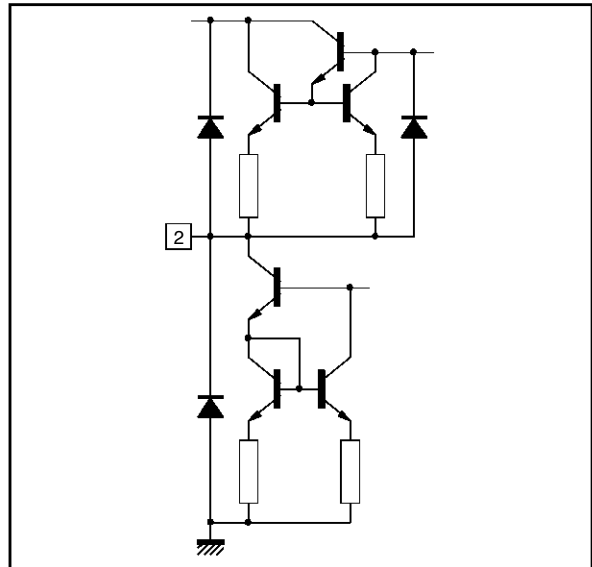

8223B-04.EPS

Figure 3 : CVBS Output

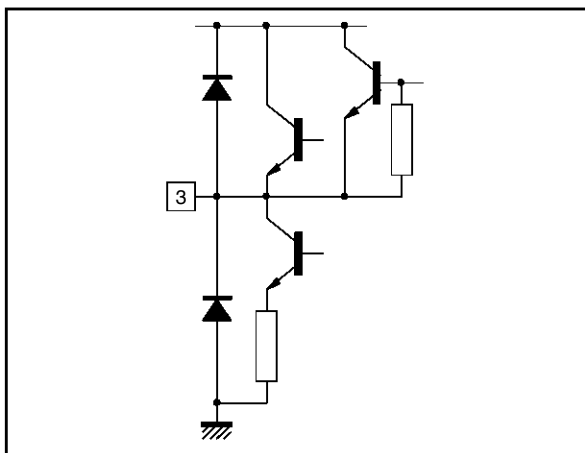

8223B-05.EPS

Figure 4 : Switching Input INT/EXT

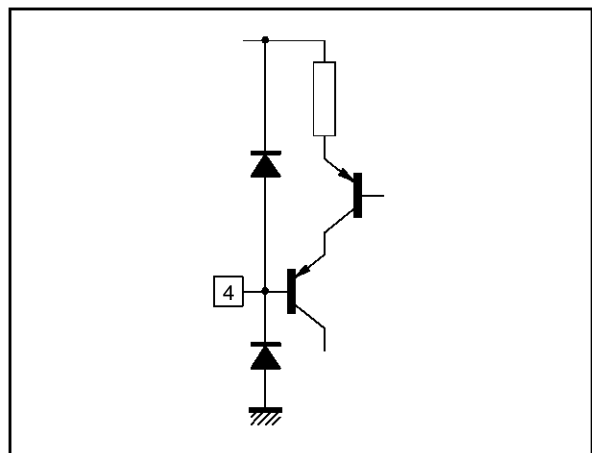

8223B-06.EPS

Figure 5 : IFLC

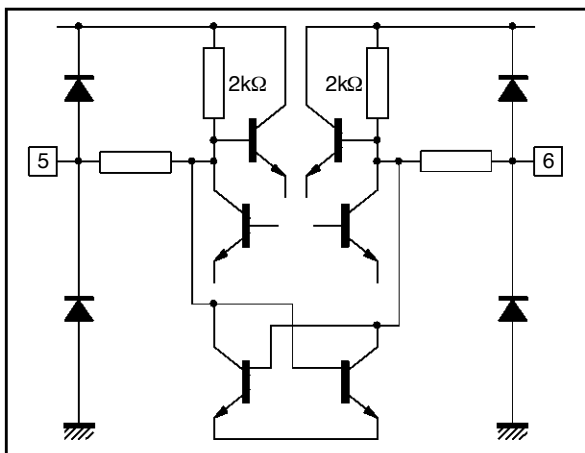

8223B-07.EPS

Figure 6 : Audio High Pass Filter

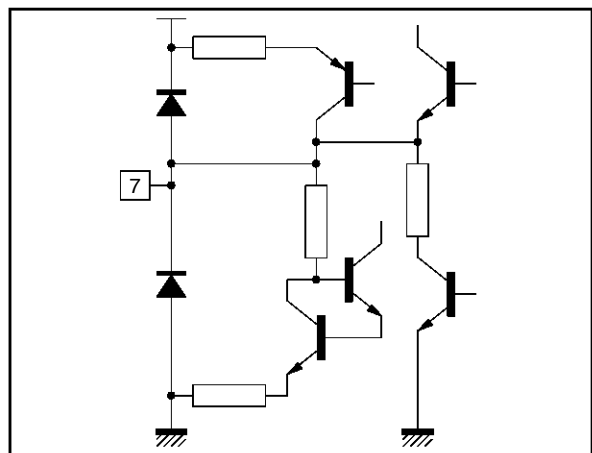

8223B-08.EPS

INPUT/OUTPUT PIN CONFIGURATION (continued)

Figure 7 : 2nd IF Sound Input (Pin 8)
Audio and 2nd IF Decoupling (Pin 9)

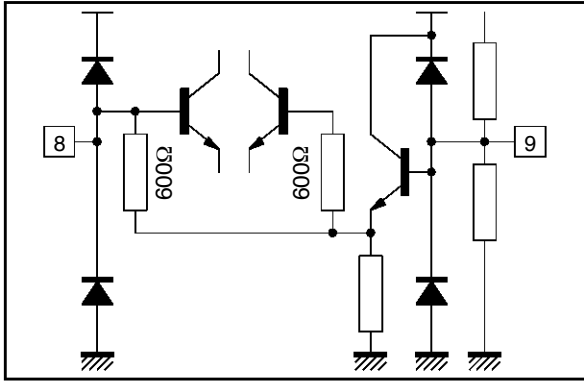

8223B-09.EPS

Figure 8 : Internal Video Input

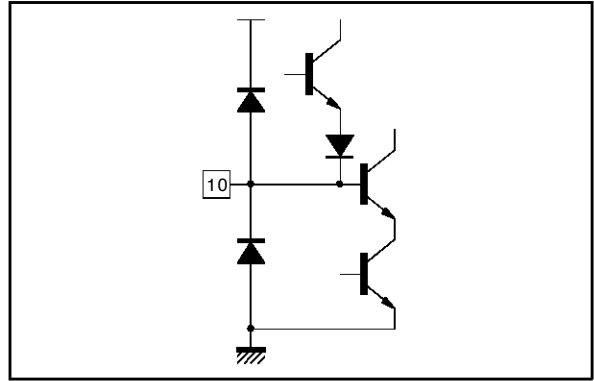

8223B-10.EPS

Figure 9 : Video Switch Output

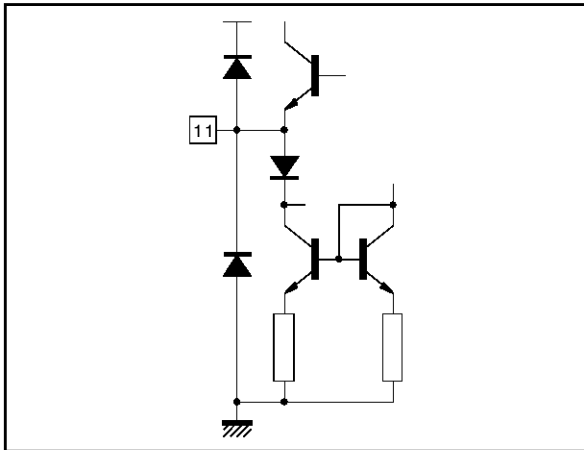

8223B-11.EPS

Figure 10 : External Video Input

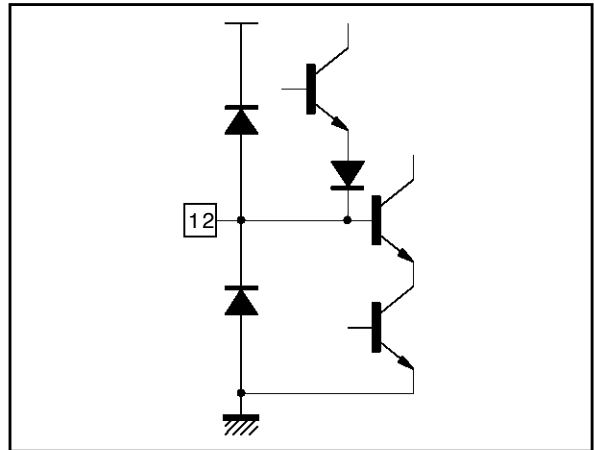

8223B-12.EPS

Figure 11 : Volume Control + Mute

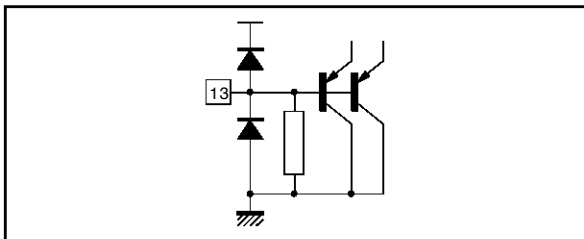

8223B-13.EPS

Figure 12 : Audio Switch Output

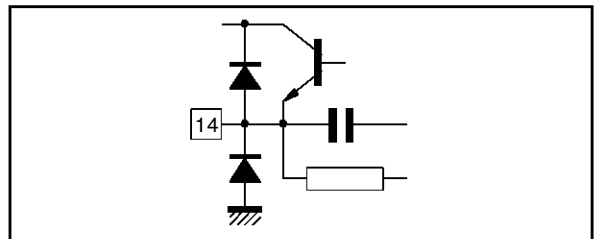

8223B-14.EPS

Figure 13 : FM Demodulated Audio Output

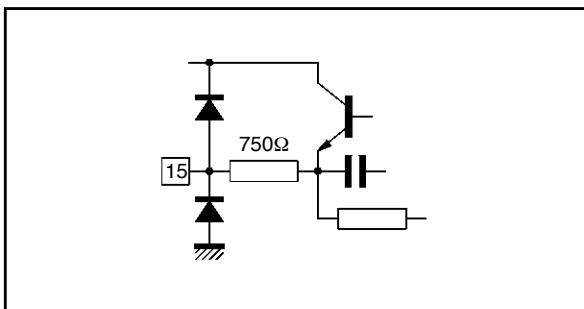

8223B-15.EPS

Figure 14 : External Audio Input

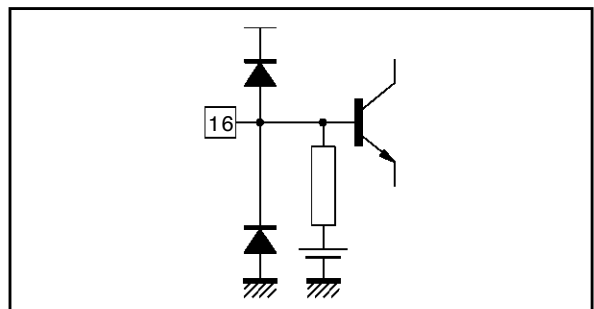

8223B-16.EPS

INPUT/OUTPUT PIN CONFIGURATION (continued)

Figure 15 : V_{CC}

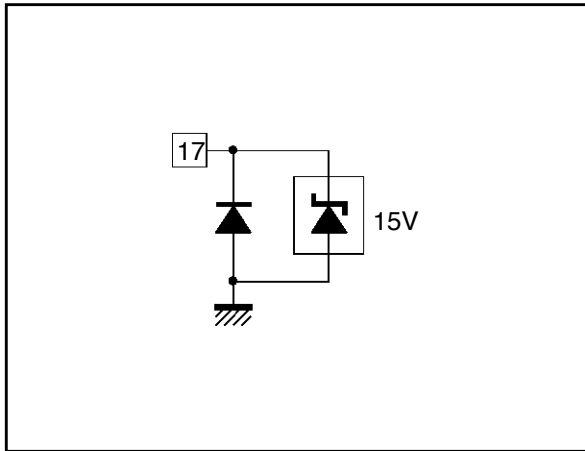

Figure 16 : IF Input

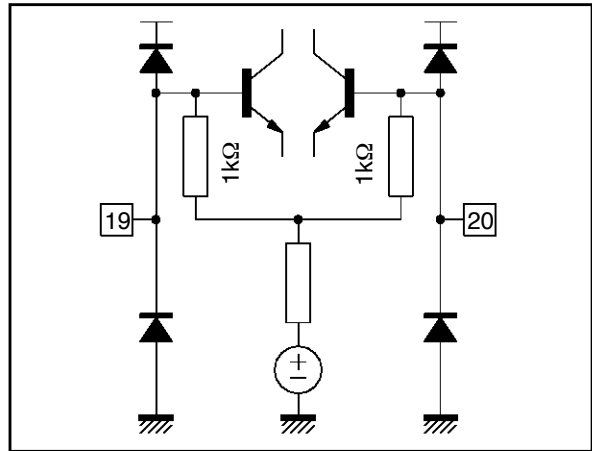

Figure 18 : AGC Capacitor

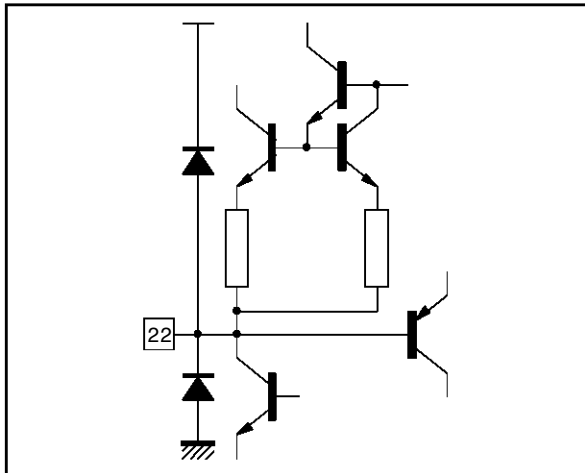

Figure 19 : Tuner AGC Output

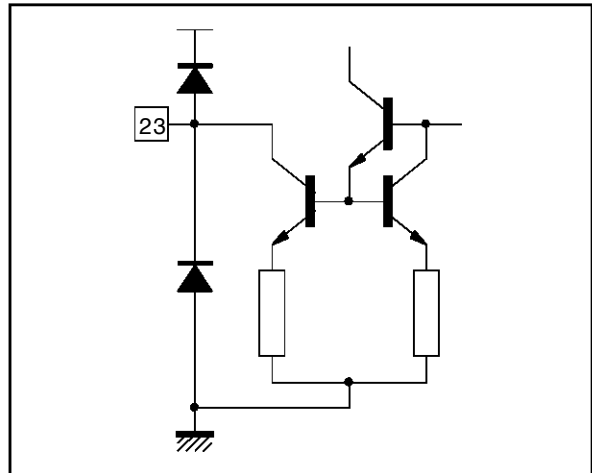

Figure 20 : Tuner AGC Starting Point Adjustment

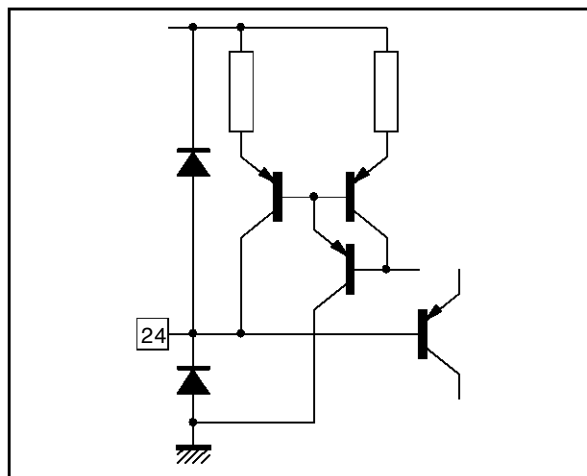
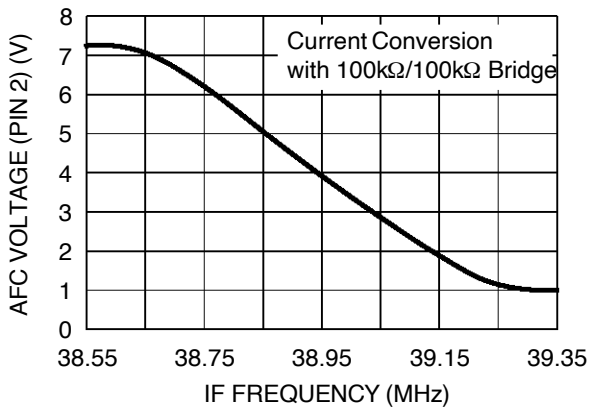
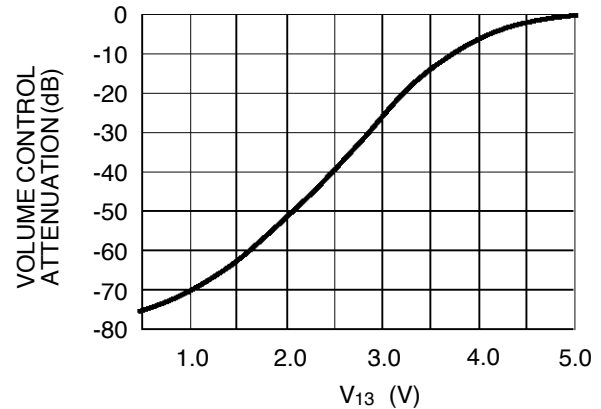

Figure 21 : AFC Voltage Pin 2 vs IF Frequency



8223B-22.EPS

Figure 22 : Volume Control Attenuation vs V_{13}



8223B-23.EPS

Figure 23 : Tuner AGC Output Current vs V_{IN} (R24 is external adjustment Pin 24)

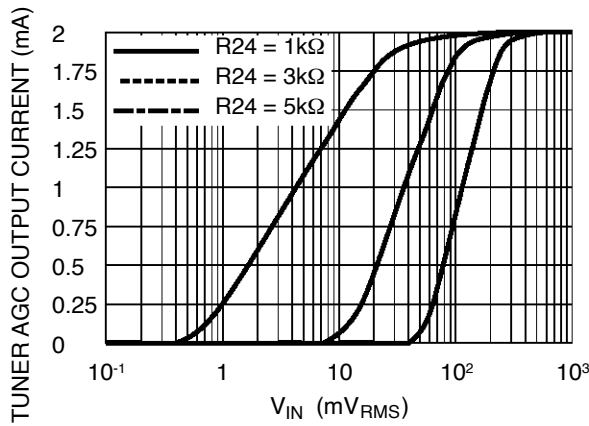

8223B-24.EPS

Figure 24 : Video Signal to Noise Ratio (Pin 3) as a function of IF Input Signal (Pins 19-20) Weighted CCIR-567

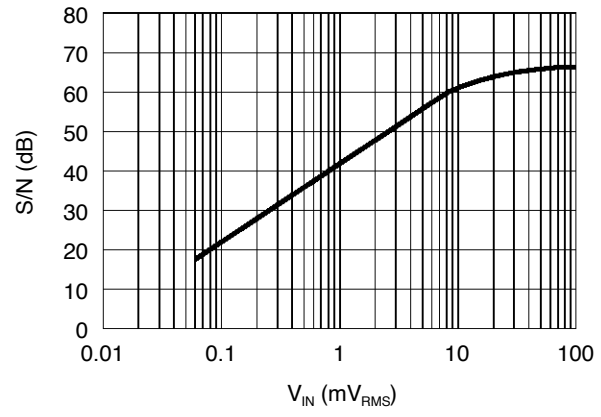

8223B-25.EPS

Figure 25 : Black and White Noise Inverter

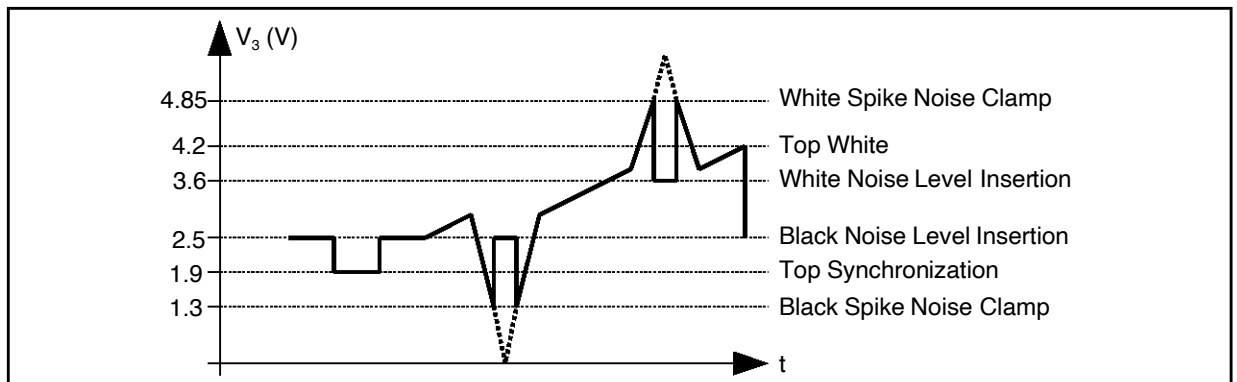

8223B-26.EPS

APPLICATION DIAGRAM (B/G/D/K)

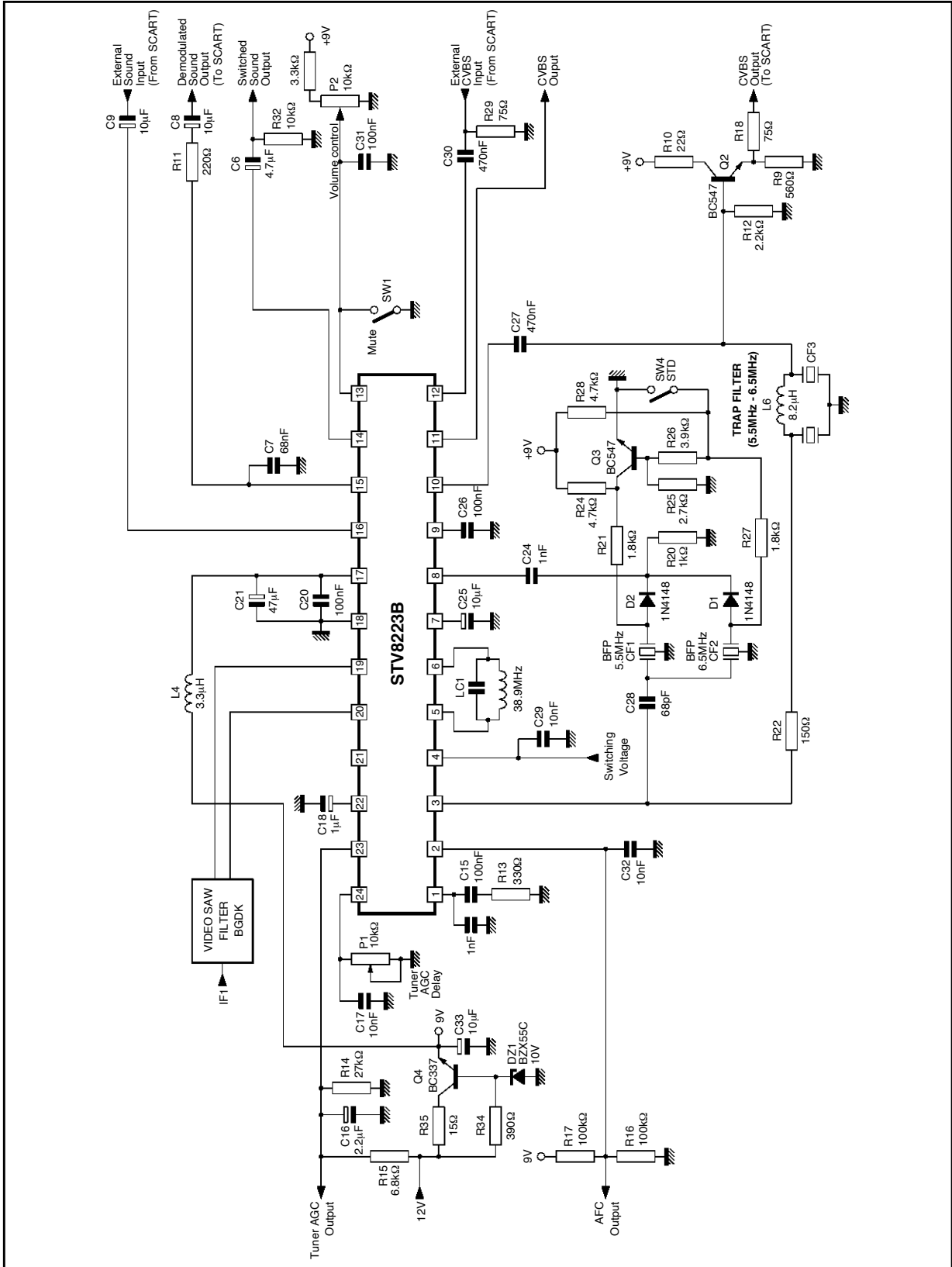

8223B-27.EPS

PACKAGE MECHANICAL DATA
24 PINS - PLASTIC SHRINK DIP

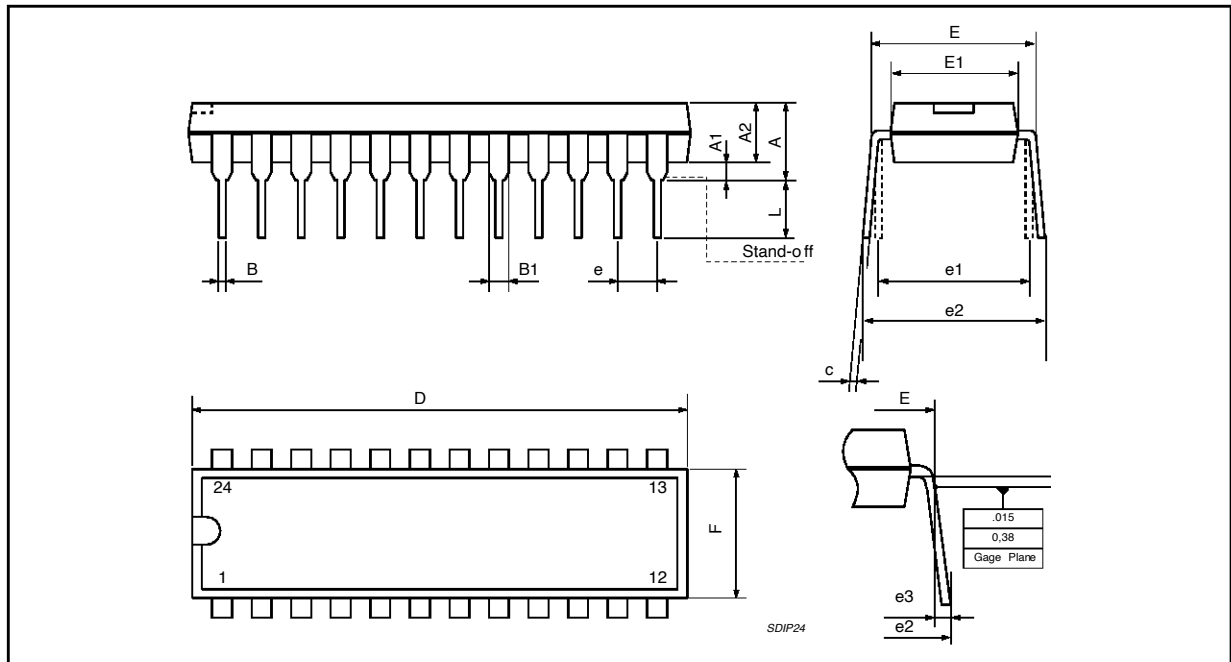

Dimensions	Millimeters			Inches		
	Min.	Typ.	Max.	Min.	Typ.	Max.
A			5.08			0.20
A1	0.51			0.020		
	3.05	3.30	4.57	0.120	0.130	0.180
B	0.36	0.46	0.56	0.0142	0.0181	0.0220
B1	0.76	1.02	1.14	0.030	0.040	0.045
C	0.23	0.25	0.38	0.0090	0.0098	0.0150
D	22.61	22.86	23.11	0.890	0.90	0.910
E	7.62		8.64	0.30		0.340
E1	6.10	6.40	6.86	0.240	0.252	0.270
e		1.778			0.070	
e1		7.62			0.30	
e2			10.92			0.430
e3			1.52			0.060
L	2.54	3.30	3.81	0.10	0.130	0.150

Information furnished is believed to be accurate and reliable. However, SGS-THOMSON Microelectronics assumes no responsibility for the consequences of use of such information nor for any infringement of patents or other rights of third parties which may result from its use. No licence is granted by implication or otherwise under any patent or patent rights of SGS-THOMSON Microelectronics. Specifications mentioned in this publication are subject to change without notice. This publication supersedes and replaces all information previously supplied. SGS-THOMSON Microelectronics products are not authorized for use as critical components in life support devices or systems without express written approval of SGS-THOMSON Microelectronics.

© 1997 SGS-THOMSON Microelectronics - All Rights Reserved

Purchase of I²C Components of SGS-THOMSON Microelectronics, conveys a license under the Philips I²C Patent. Rights to use these components in a I²C system, is granted provided that the system conforms to the I²C Standard Specifications as defined by Philips.

SGS-THOMSON Microelectronics GROUP OF COMPANIES

Australia - Brazil - Canada - China - France - Germany - Hong Kong - Italy - Japan - Korea - Malaysia - Malta - Morocco
The Netherlands - Singapore - Spain - Sweden - Switzerland - Taiwan - Thailand - United Kingdom - U.S.A.