

2-HEAD PLAYBACK AND RECORD AMPLIFIER FOR VCR

- ONE 5V POWER SUPPLY
- PLAYBACK/RECORD MODE SELECTION THROUGH A LOGIC INPUT
- SO16 PACKAGE
- NO ADJUSTMENT FOR LUMINANCE RECORDING

PLAYBACK MODE

- LOW NOISE AND WIDE BAND AMPLIFIERS FOR 2 HEADS
- AUTOMATIC OFFSET CANCELLATION BETWEEN THE 2 SELECTED HEADS
- ONE PLAYBACK OUTPUT
- ONE OUTPUT FOR AUTOMATIC VIDEO TRACKING

RECORD MODE

- RECORD AGC AMPLIFIER SAMPLED BY SYNCHRO SIGNAL
- RECORDING SIGNAL LEVEL ADJUSTABLE BY EXTERNAL RESISTOR

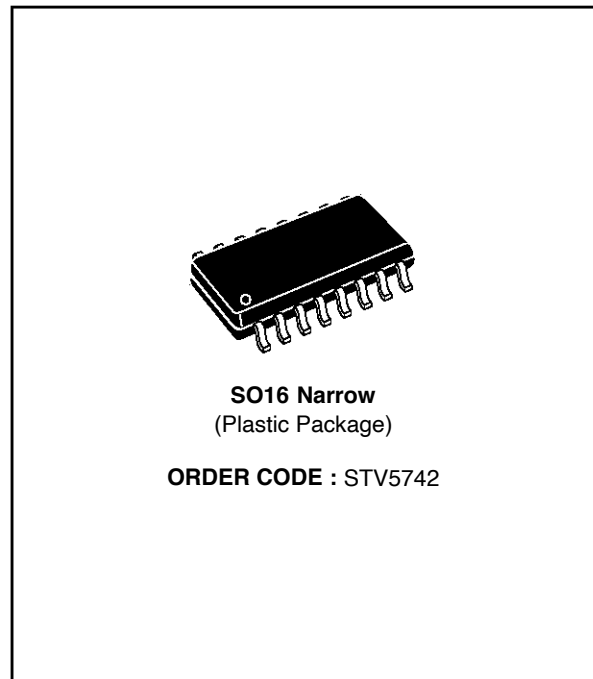

PIN CONNECTIONS

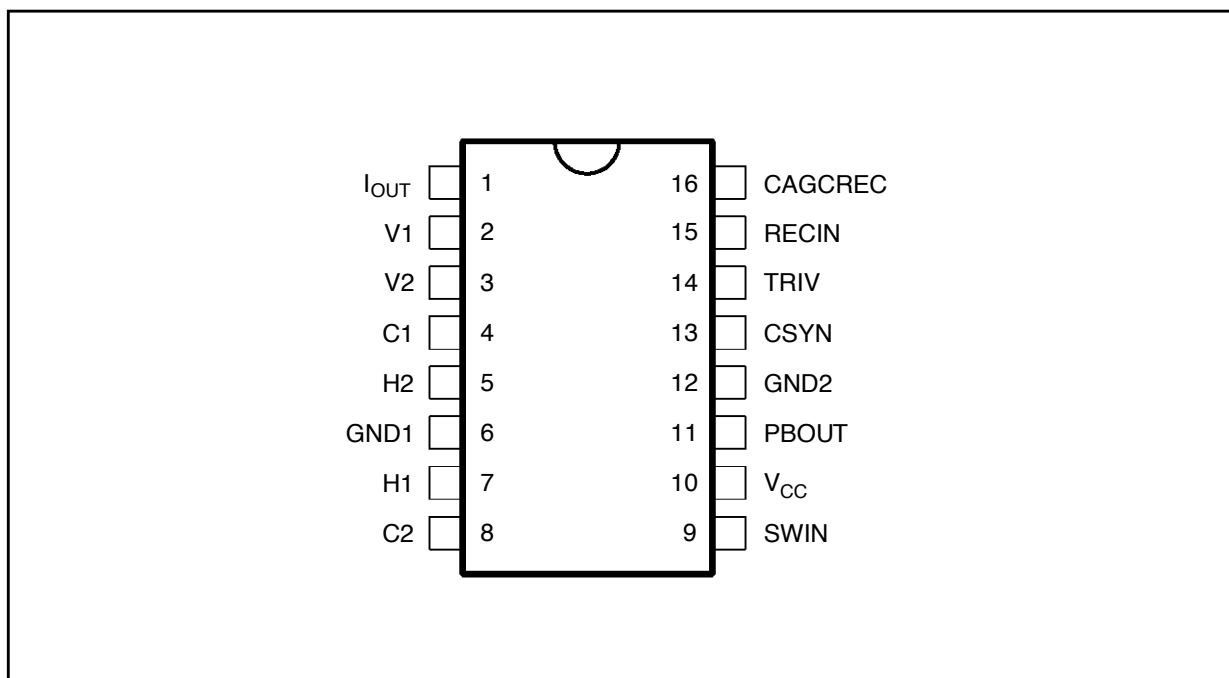

BLOCK DIAGRAM

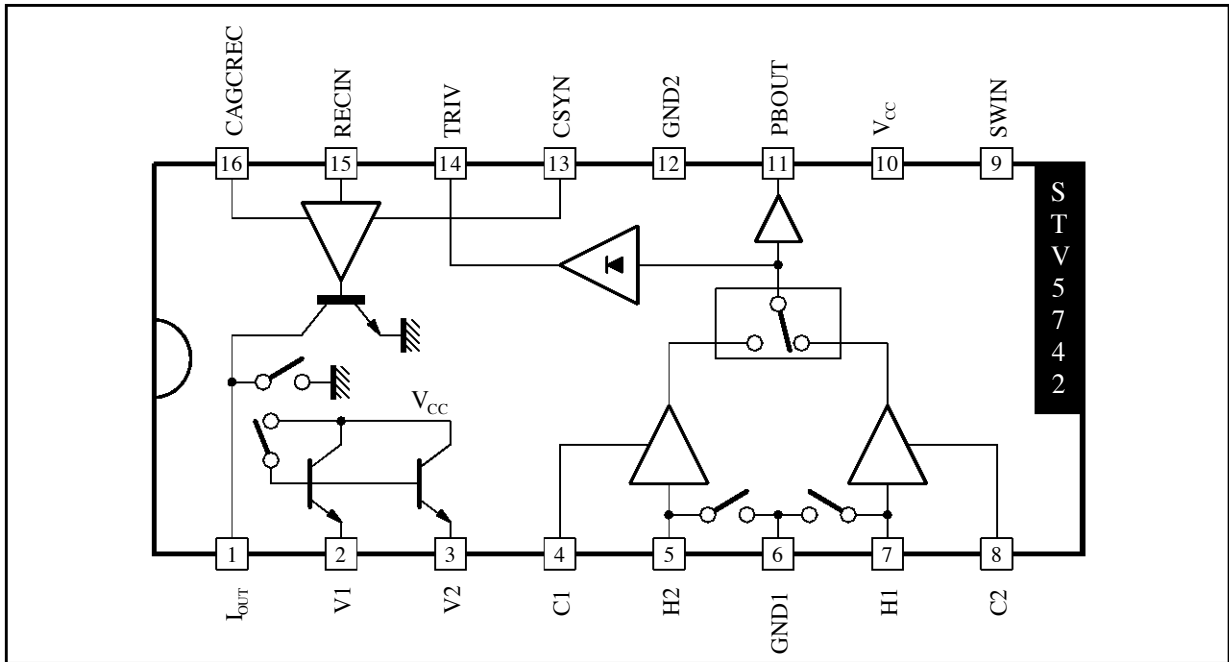

5742-02.EPS

ABSOLUTE MAXIMUM RATINGS

Symbol	Parameter	Value	Unit
V_{CC}	Power Supply Voltage	6	V
T_j	Junction Temperature	150	°C
T_{oper}	Operating Temperature	0, +70	°C

5742-01.TBL

THERMAL DATA

Symbol	Parameter	Value	Unit
$R_{th(j-a)}$	Junction-ambient Thermal Resistance	Max. 100	°C/W

5742-02.TBL

RECOMMENDED OPERATING CHARACTERISTICS

Symbol	Parameter	Min.	Typ.	Max.	Unit
V_{CC}	Power Supply	4.75	5	5.25	V
CAGC	Capacitance on Pin CAGCREC	4.7			nF
RECADJ	Record Biasing Resistor	10		33	kΩ

5742-03.TBL

ELECTRICAL CHARACTERISTICS ($T_{amb} = 25^{\circ}\text{C}$, unless otherwise specified)**Playback Mode** ($V_{CC} = 5\text{V}$, no load on Pin PBOUT, Recadj = 12k Ω)

Symbol	Parameter	Test Conditions	Min.	Typ.	Max.	Unit
PLAYBACK AMPLIFIER						
I _{CC1}	Supply Current		19	29	39	mA
GPB	Playback Gain	Sinewave 600kHz, 0.4mV _{PP} on inputs	58	60	62	dB
EN	Equivalent Voltage Noise	Input grounded via I _{OUT} Pin @ 600kHz, BW = 10kHz		0.45	0.6	$\frac{\text{nV}}{\sqrt{\text{Hz}}}$
IN	Equivalent Input Current Noise	Input open @ 6MHz, BW = 10kHz		2.5		$\frac{\text{pA}}{\sqrt{\text{Hz}}}$
CRT1	Crosstalk	Sinewave @ 4MHz, 0.4mV _{PP}		-35	-30	dB
RPBSW	Playback Switch on Resistor	@ 6MHz	1	5	10	Ω
BWLCF	Attenuation @ 100KHz	Reference level @ 600kHz	-3	0	1	dB
BWHCF	Attenuation @ 8MHz	Reference level @ 4MHz	-3	-1	0	dB
C _{IN}	Input Capacitance	@ 6MHz, 22nF between Vi/Hi	40	50	60	pF
Z _{IN}	Input Impedance	@ 6MHz	300	450	600	Ω
ZCPB	Output Resistance	DC	5	24	50	Ω
VDCPB1	DC Level on Pin PBOUT		1.6	2	2.4	V
DVDC	Head Switch Offset		-0.1	0	0.1	V
SHPB1	2nd Harmonic	Sinewave @ 4MHz, 0.4mV _{PP}		-45	-40	dB

TRIV FUNCTION

TRIV0	Output Level (1)	No input signal	0	0.3	1	V
TRIV1	Output Level (2)	Sinewave @ 4MHz, 100mV _{PP} @ PBOUT		1.3		V
TRIV4	Output Level (3)	Sinewave @ 4MHz, 400mV _{PP} @ PBOUT	2.5	3.1	3.5	V
TRIV6	Output Level (4)	Sinewave @ 4MHz, 600mV _{PP} @ PBOUT	3.2	3.7	4.2	V
TRIV1-TRIV0			0.5	1	-	V

Record Mode ($V_{CC} = 5\text{V}$, Recadj = 12k Ω , SWR = 5V, CAGCREC = 470pF, RRCY = 2.2k Ω , RRCC = 8.2k Ω , Load 10 μH /1k Ω for each simulated head)

Symbol	Parameter	Test Conditions	Min.	Typ.	Max.	Unit
RECORD AMPLIFIER						
I _{CC2}	Current Supply		55	85	115	mA
IHA0	DC Current through I _{OUT}		28	38	47.5	mA
IHA1	Fundamental	VRCY = 300mV _{PP} @ 4MHz	34	36	38	mA _{PP}
IHA2	2nd Harmonic	VRCY = 300mV _{PP} @ 4MHz		-40	-36	dB
IHA2M	2nd Harmonic	VRCY = 400mV _{PP} @ 4MHz, AGC adjusted for IAH1 = 40mA _{PP}		-34	-32	dB
BWRECL	Attenuation at 100kHz	Reference level @ 600kHz, AGC locked	-3	0	1	dB
BWRECH	Attenuation at 8MHz	Reference level @ 4MHz, AGC locked	-2	-0.5	1	dB
DVLR	Record AGC Sensitivity	V _{IN} = 300mV _{PP} \pm 3dB @ f = 4MHz	-0.2	0	+0.2	dB
RIOUT	Output Resistance	$\Delta V = 5\text{V}$	3.5	5.5	-	$\kappa\Omega$
RSAT	Output Stage Resistance	$\Delta I = 10\text{mA}$	5	10	50	Ω
IRN	AGC Capacitor downloading Current	4.5V at CAGC Pin		165		μA
IRP	AGC Capacitor uploading Current	0.5V at CAGC Pin, V _{IN} = 300mV _{PP} @ 4MHz		-165		μA

SWITCHING LEVELS

VSWINH	SWIN Input Threshold	Selects head H1, 0 to 5V	1.5	2	2.5	V
VSWINL	SWIN Input Threshold	Selects head H2, 5 to 0V	1.5	2	2.5	V
ISWINH	SWIN Input Leakage Current	5V at SWIN input	5	18	50	μA
ISWINL	SWIN Input Leakage Current	0V at SWIN input	-50	-25	-5	μA
VSWRCH	SWRC Input Threshold	Selects record mode, 0 to 5V	3.2	3.4	3.8	V

5742-04-TBL

ELECTRICAL CHARACTERISTICS ($T_{amb} = 25^{\circ}C$, unless otherwise specified)

Record Mode ($V_{CC} = 5V$, $Recadj = 12k\Omega$, $SWR = 5V$, $CAGCREC = 470pF$, $RRCY = 2.2k\Omega$, $RRCC = 8.2k\Omega$, Load $10\mu H//1k\Omega$ for each simulated head) (continued)

Symbol	Parameter	Test Conditions	Min.	Typ.	Max.	Unit
SWITCHING LEVELS (continued)						
VSWRCL	SWRC Input Threshold	Selects playback mode, 5 to 0V	3.1	3.3	3.8	V
ISWRCH	SWRC Input Leakage Current	5V at SWRC input	2	5	8	mA
ISWRCL	SWRC Input Leakage Current	0V at SWRC input	-20	0	20	μA
t_{ON}	Delay	Signal appears on PBOUT		3		ms
t_1	Delay from playback to record : Signal disappears on Pin PBOUT	22nF between Hi/Vi		1		μs
t_2	Delay from record to playback : Signal appears on Pin PBOUT	22nF between Hi/Vi		5		ms
t_3	Delay from playback to record : Signal appears on Pin I_{OUT}			25		μs
t_4	Delay from record to playback : Signal disappears on Pin I_{OUT}			7		μs
VCSYH	CSYN Input Threshold	Sampling on ($I = -25\mu A$)	2.2	2.5	2.8	V
VCSYL	CSYN Input Threshold	Sampling off ($I = 25\mu A$)	2.2	2.5	2.8	V
ICSYH	Leakage Current	Sampling on			-10	μA
ICSYL	Leakage Current	Sampling off	10			μA

5742-05.TBL

INTERNAL SCHEMATICS

Figure 1

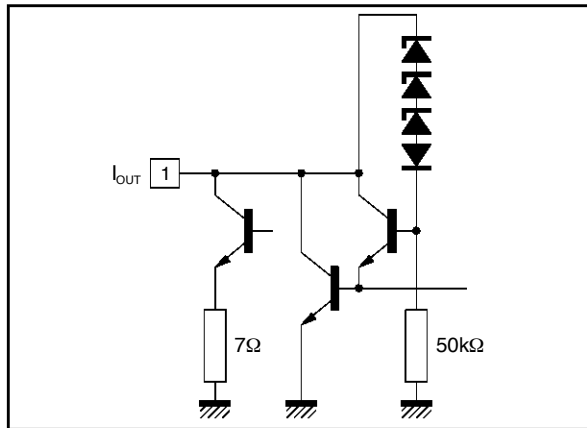

5742-04.EPS

Figure 2

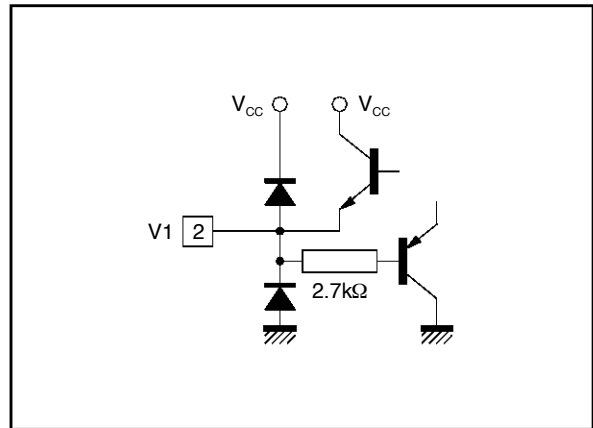

5742-05.EPS

Figure 3

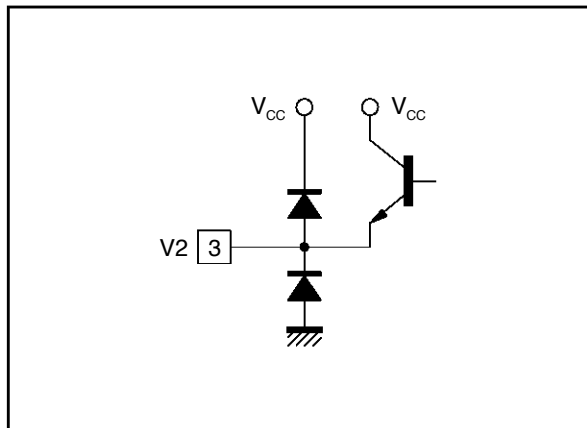

5742-06.EPS

Figure 4

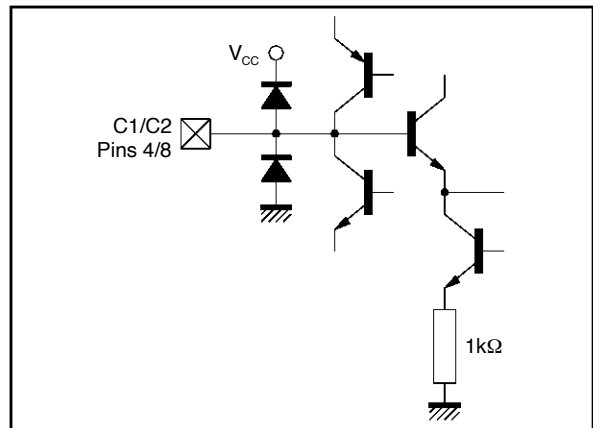

5742-07.EPS

INTERNAL SCHEMATICS (continued)

Figure 5

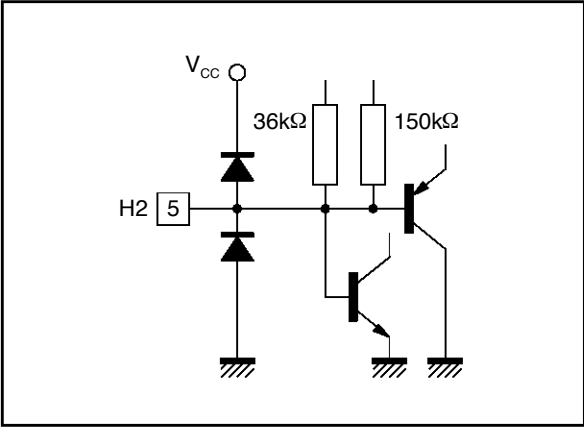

5742-08.EPS

Figure 6

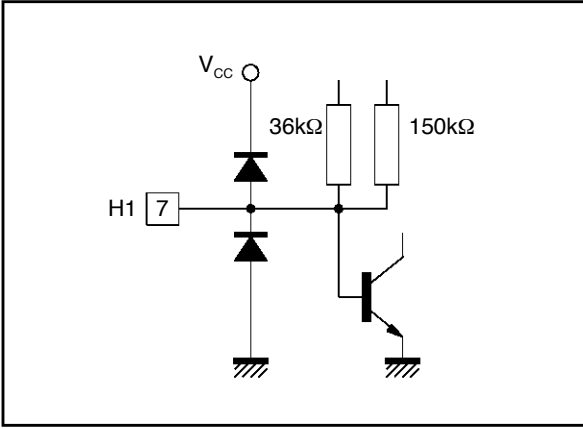

5742-09.EPS

Figure 7

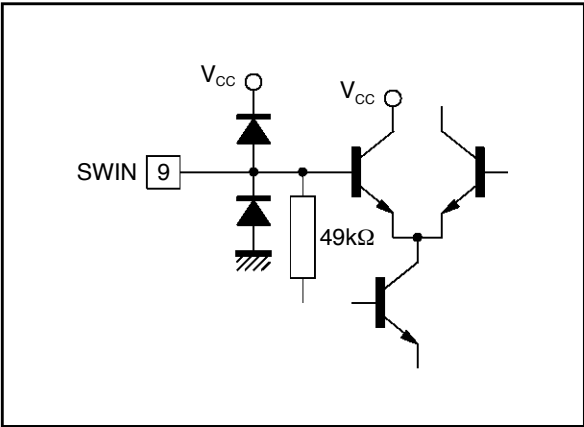

5742-10.EPS

Figure 8

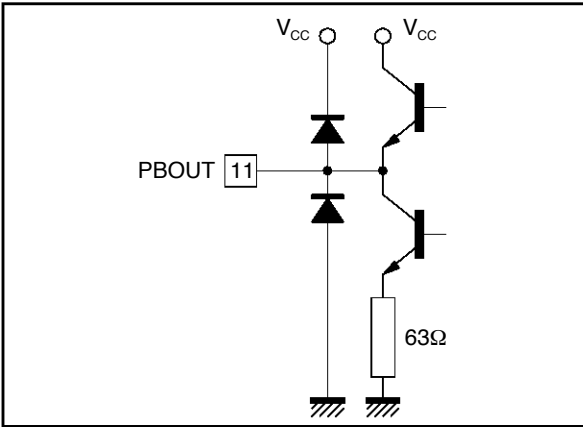

5742-11.EPS

Figure 9

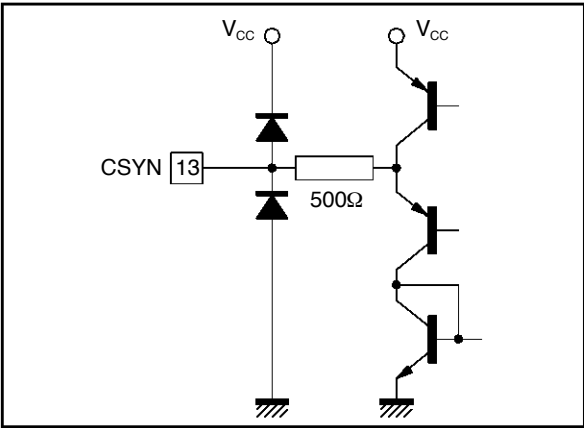

5742-12.EPS

Figure 10

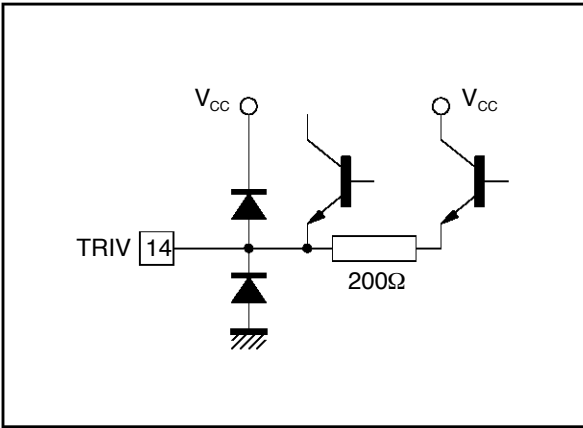

5742-13.EPS

INTERNAL SCHEMATICS (continued)

Figure 11

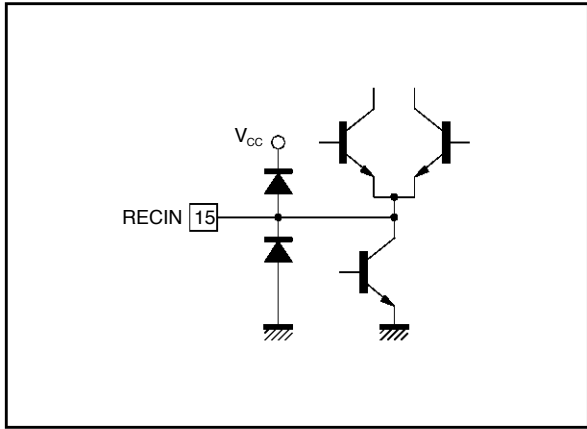
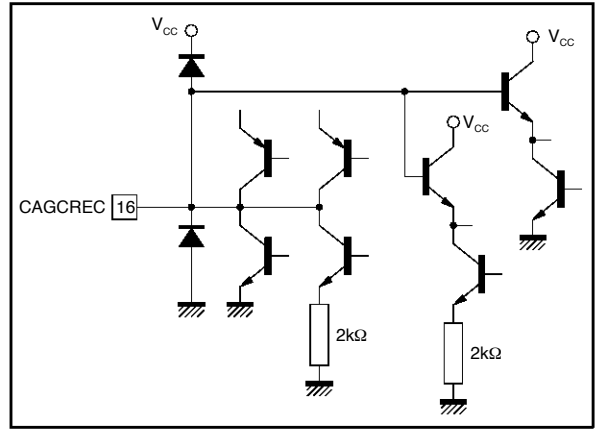
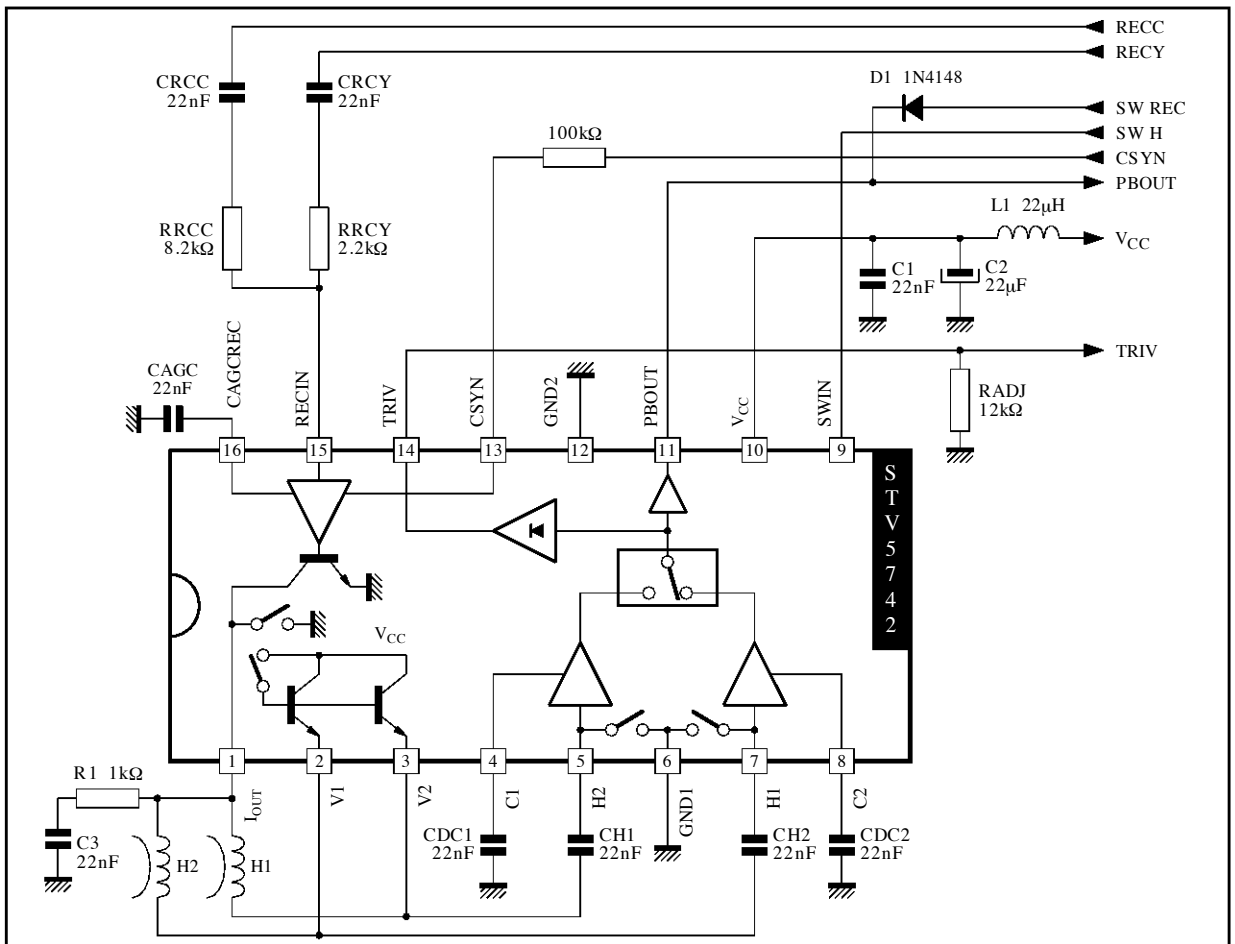

Figure 12



APPLICATION DIAGRAM



PACKAGE MECHANICAL DATA
 16 PINS - PLASTIC MICROPACKAGE (SO)

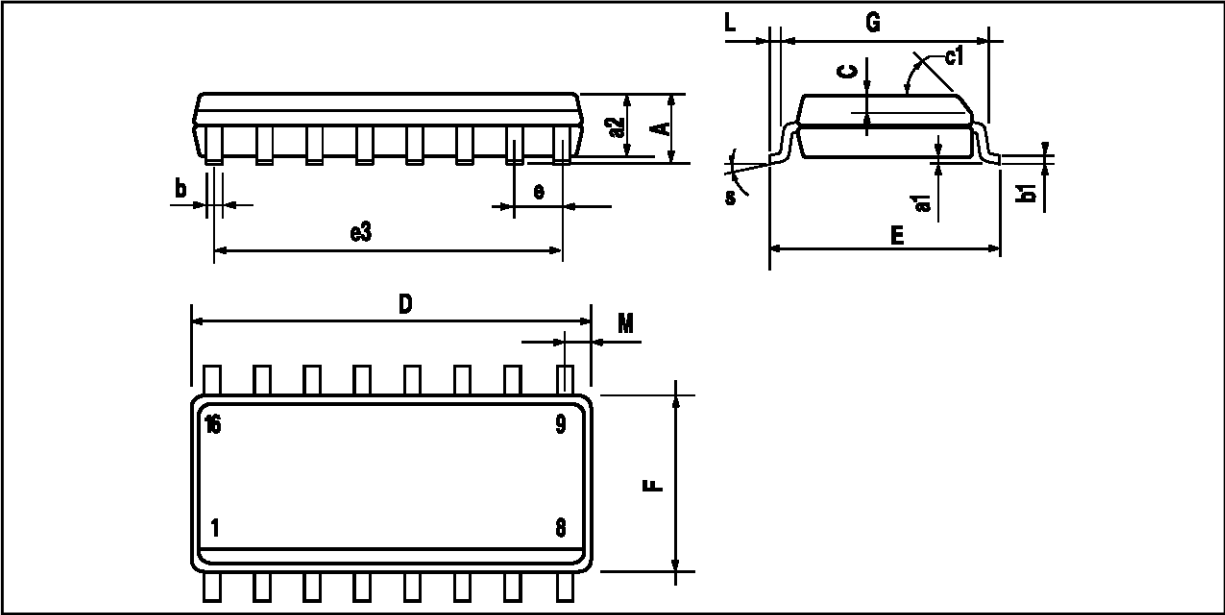

PM-SO16N.EPS

Dimensions	Millimeters			Inches		
	Min.	Typ.	Max.	Min.	Typ.	Max.
A			1.75			0.069
a1	0.1		0.25	0.004		0.009
a2			1.6			0.063
b	0.35		0.46	0.014		0.018
b1	0.19		0.25	0.007		0.010
C		0.5			0.020	
c1	45° (typ.)					
D	9.8		10	0.386		0.394
E	5.8		6.2	0.228		0.244
e		1.27			0.050	
e3		8.89			0.350	
F	3.8		4.0	0.150		0.157
L	0.4		1.27	0.016		0.050
M			0.62			0.024
S	8° (Max.)					

SO16N.TBL

Information furnished is believed to be accurate and reliable. However, SGS-THOMSON Microelectronics assumes no responsibility for the consequences of use of such information nor for any infringement of patents or other rights of third parties which may result from its use. No licence is granted by implication or otherwise under any patent or patent rights of SGS-THOMSON Microelectronics. Specifications mentioned in this publication are subject to change without notice. This publication supersedes and replaces all information previously supplied. SGS-THOMSON Microelectronics products are not authorized for use as critical components in life support devices or systems without express written approval of SGS-THOMSON Microelectronics.

© 1997 SGS-THOMSON Microelectronics - All Rights Reserved

Purchase of I²C Components of SGS-THOMSON Microelectronics, conveys a license under the Philips I²C Patent. Rights to use these components in a I²C system, is granted provided that the system conforms to the I²C Standard Specifications as defined by Philips.

SGS-THOMSON Microelectronics GROUP OF COMPANIES

Australia - Brazil - Canada - China - France - Germany - Hong Kong - Italy - Japan - Korea - Malaysia - Malta - Morocco
 The Netherlands - Singapore - Spain - Sweden - Switzerland - Taiwan - Thailand - United Kingdom - U.S.A.