

BASE BAND CHROMA DELAY LINE

PRELIMINARY DATA

- DUAL SWITCHED CAPACITOR DELAY LINE
- 3MHz CLOCK DERIVED FROM 6MHz VCO LOCKED BY THE BURST GATE PULSE
- SAMPLE AND HOLD CIRCUITS AND LOW-PASS FILTERS TO SUPPRESS THE 3MHz CLOCK RESIDUAL
- CLAMPED B-Y AND R-Y INPUTS
- OUTPUT BUFFERS
- **ADJUSTMENT-FREE APPLICATION**
- DIP14 PACKAGE

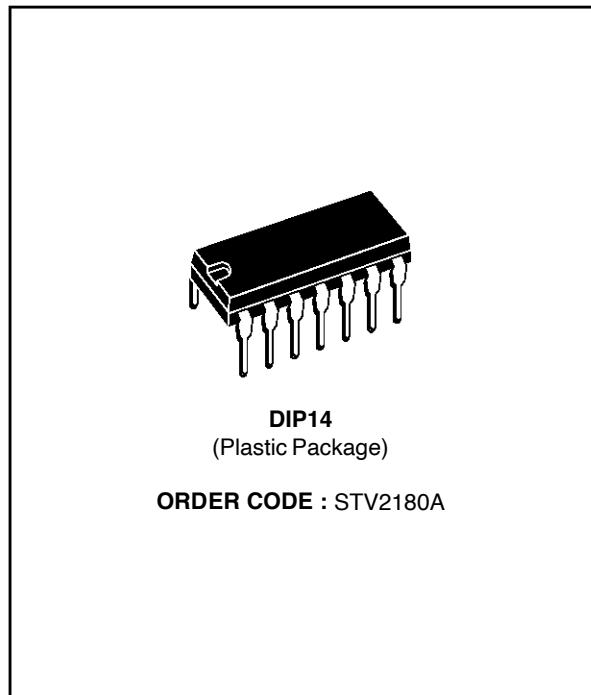

DESCRIPTION

The STV2180A is an integrated base band chroma delay line with one line delay, which has been designed to match chroma decoders with colour difference signal outputs (R-Y) and (B-Y).

PIN CONNECTIONS

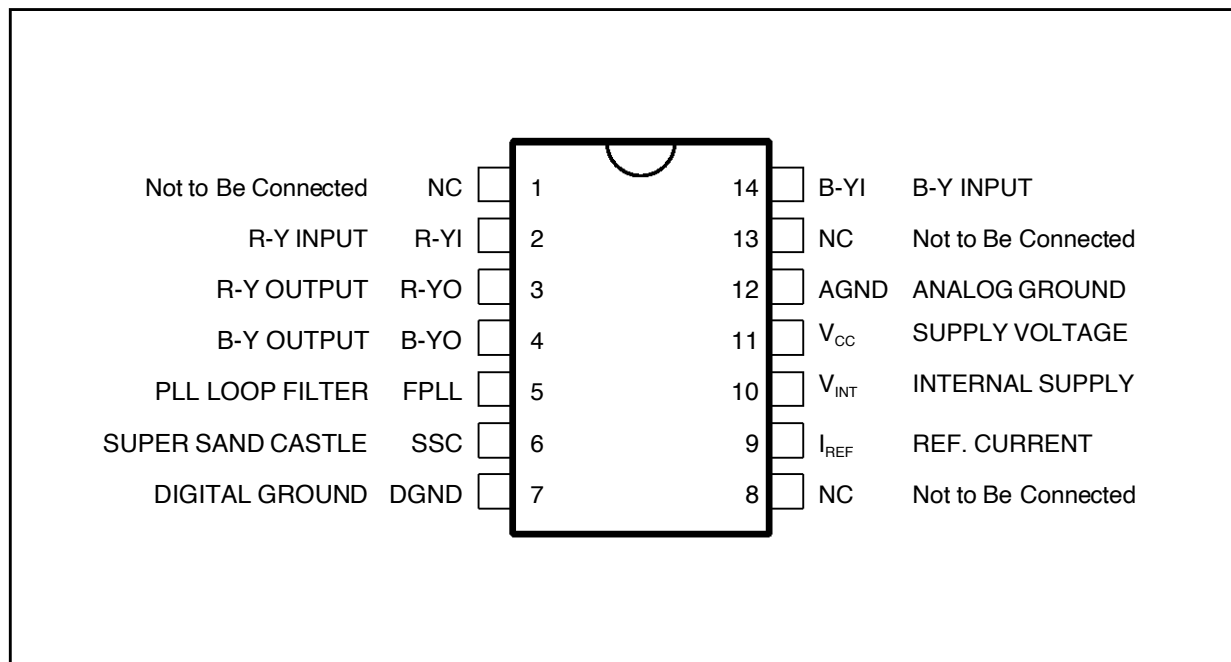

2180A-01EFS

BLOCK DIAGRAM

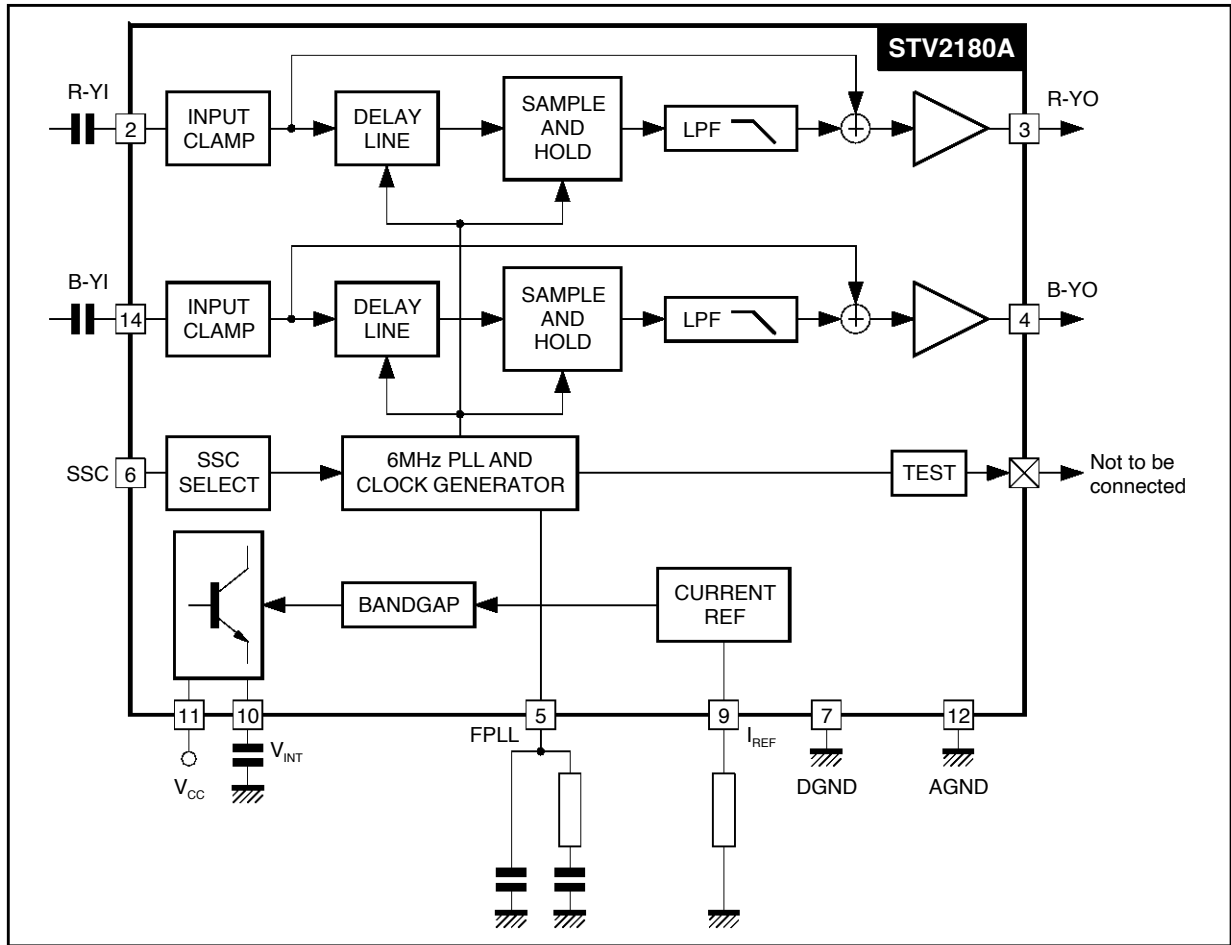

2180A-02.EPS

ABSOLUTE MAXIMUM RATINGS

Symbol	Parameter	Value	Unit
V _{CC}	Supply Voltage (Pin 11)	11	V
T _A	Operating Ambient Temperature	0 to 70	°C
T _{stg}	Storage Temperature	-25 to +150	°C
R _{th(j-a)}	Junction-Ambiant Thermal Resistance P _d = 1W	90	°C/W

2180A-01.TBL

ELECTRICAL CHARACTERISTICS

$T_{amb} = 25^{\circ}\text{C}$, $V_{CC} = 9\text{V}$, $R_9 = 4.02\text{k}\Omega$, unless otherwise specified

Symbol	Parameter	Test Conditions	Min.	Typ.	Max.	Unit
--------	-----------	-----------------	------	------	------	------

SUPPLY/ V_{REF} (Pins 11 and 10)

V_{CC}	Supply Voltage		8.5	9	9.5	V
I_{CC}	Supply Current			15	25	mA
P_d	Power Consumption	$V_{CC} = 9\text{V}$		135	240	mW
V_{int}	Internal Voltage			7		V

SAND CASTLE INPUT (Pin 6)

FSSC	Burst Gate Frequency	No input signal	14.5	15.625	16.5	kHz
V_{TH}	Threshold Voltage (Burst Gate)		3.2	3.5	3.8	V
C_{in}	Input Capacitance				12	pF

COLOR DIFFERENCE INPUT SIGNALS (Pins 2 and 14)

R-Y IPN	R-Y Typical Input Signal PAL & NTSC	Peak-to-peak value		525		mV _{PP}
R-Y IS	R-Y Typical Input Signal SECAM	Peak-to-peak value		1.05		V _{PP}
B-Y IPN	B-Y Typical Input Signal PAL & NTSC	Peak-to-peak value		665		mV _{PP}
B-Y IS	B-Y Typical Input Signal SECAM	Peak-to-peak value		1.33		V _{PP}
R_{in}	Input Resistance		10			k Ω
C_{in}	Input Capacitance				12	pF
V_{Clamp}	Clamping Voltage			2.7		V
I_{Clamp}	Clamping Current	$V_{in} = V_{Clamp} \pm 0.2\text{V}$		± 50		μA

COLOR DIFFERENCE OUTPUT SIGNALS (Pins 3 and 4)

B-Y O	B-Y Output Signal	Peak-to-peak value			1.8	V _{PP}
R-Y O	R-Y Output Signal	Peak-to-peak value			1.8	V _{PP}
DG	Differential Gain	SECAM V_n/V_{n-1} : $V_{in} = 1\text{V}_{PP}$	-0.4	0	+0.4	dB
GPN	PAL-NTSC Gain	$V_{in} = 0.5\text{V}_{PP}$	5.8	6.3	6.8	dB
GS	SECAM Gain	$V_{in} = 1\text{V}_{PP}$	-0.5	0	+0.5	dB
V_{Noise}	RMS Noise Voltage	$R_i = 300\Omega$ $BW = 10\text{kHz to } 1\text{MHz}$		2		mV _{RMS}
R_{out}	Output Resistance			200		Ω
Delay	Delayed Signal Delay	Referred to non delayed output	63.93	64	64.07	μs
Non Delay	Non Delayed Signal Delay	Referred to input		100		ns
TR	Output Signal Transient Time	500ns transient input signal		650	1000	ns

PLL FILTER LOOP (Pin 5)

I_{Charg}	Charging Current			100		μA
V_{PLL}	DC Voltage			3.5		V

CURRENT REFERENCE (Pin 9)

V_{DC}	DC Voltage	$R_9 = 4.02\text{k}\Omega$ to ground		1.15		V
----------	------------	--------------------------------------	--	------	--	---

2180A-02.TBL

INPUT/OUTPUT PIN CONFIGURATION

Pins 10, 11 : V_{INT} and V_{CC}

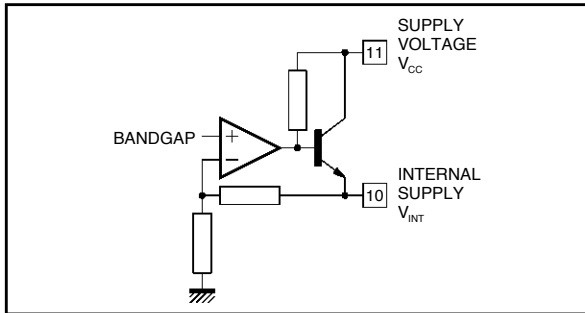

Pins 7, 11, 12 : $DGND$, V_{CC} , $AGND$

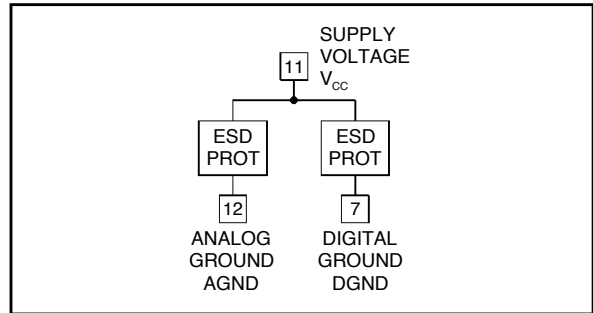

Pins 2, 14 : R-YI, B-YI

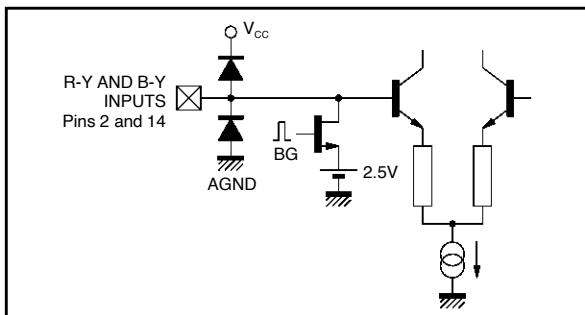

Pins 3, 4 : R-YO, B-YO

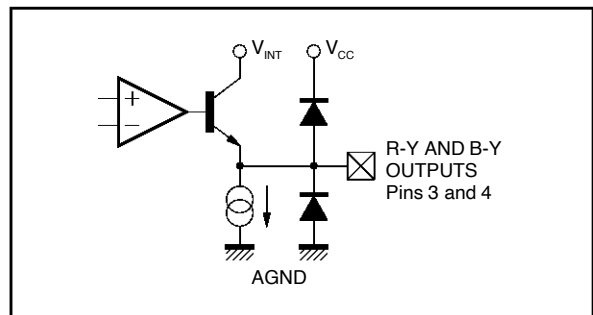

Pin 6 : SSC

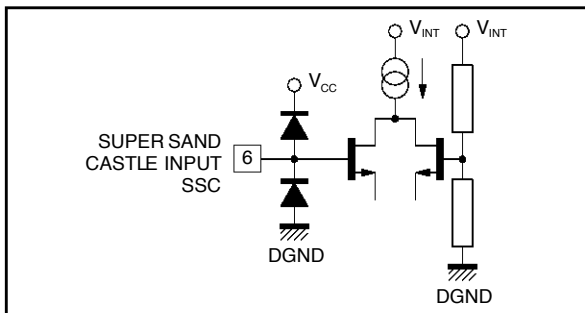

Pin 9 : I_{REF}

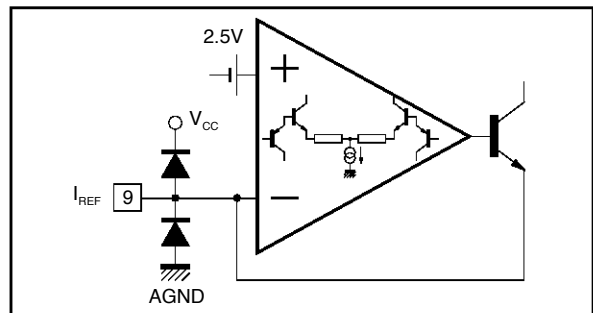

Pin 5 : FPLL

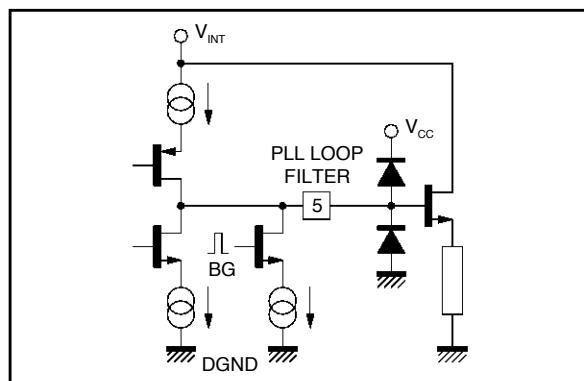

TYPICAL APPLICATION

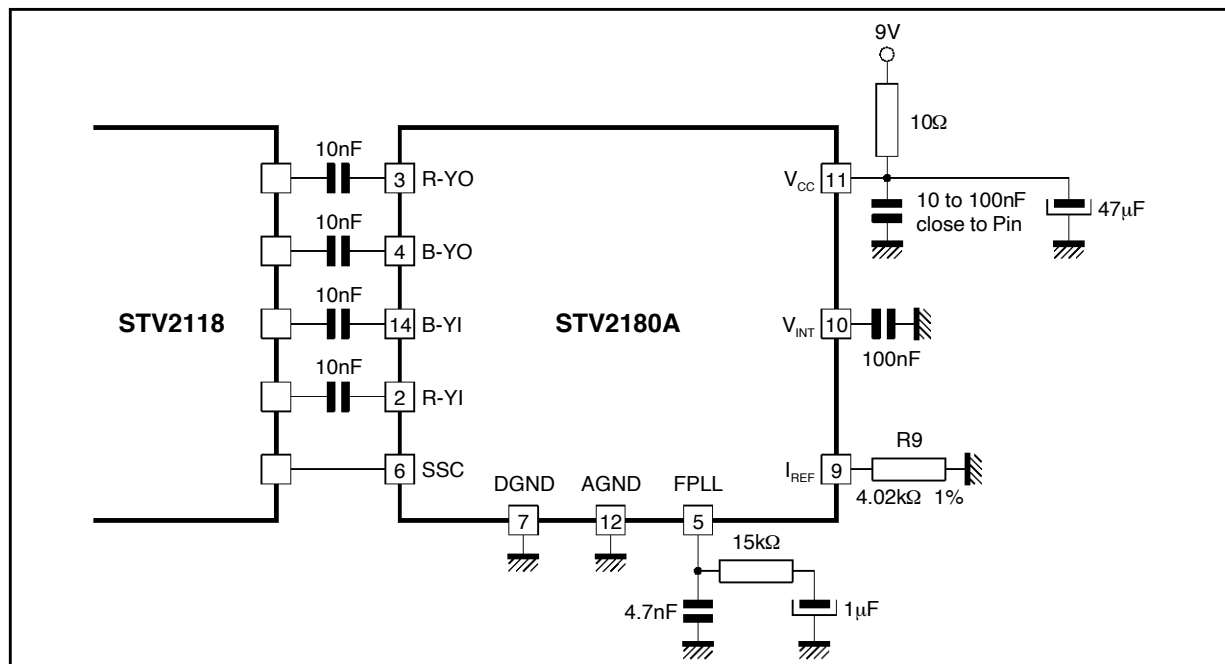

2180A-10.EPS

PACKAGE MECHANICAL DATA
14 PINS - PLASTIC PACKAGE

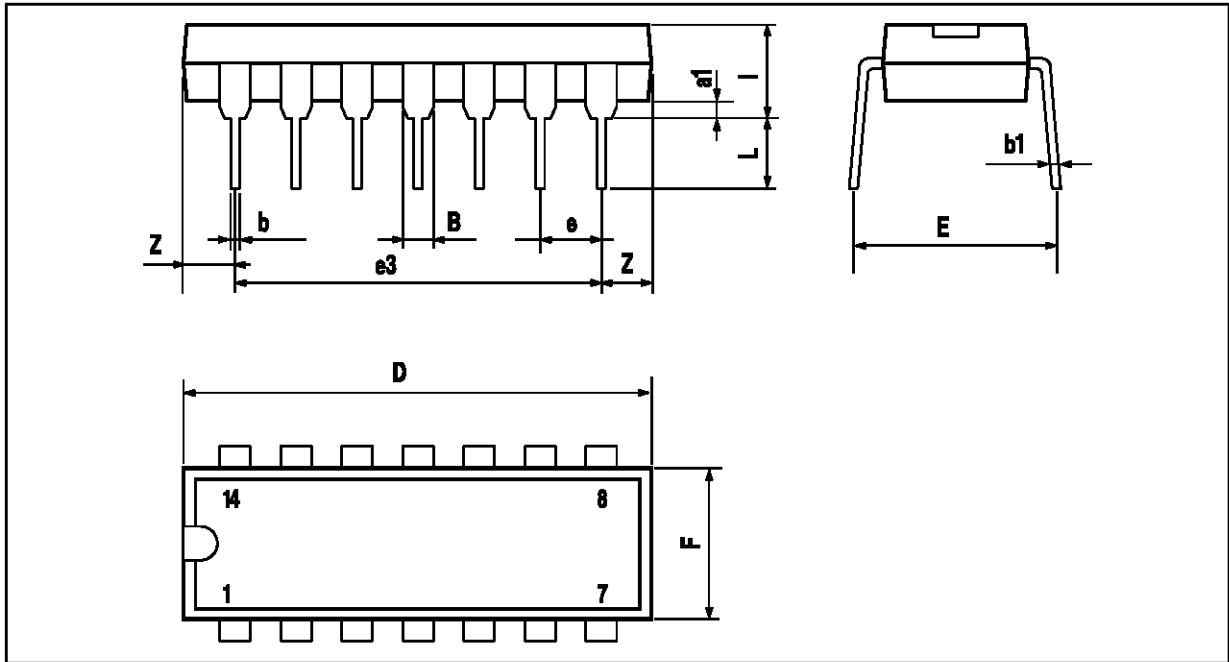

PM-DIP14LEFS

Dimensions	Millimeters			Inches		
	Min.	Typ.	Max.	Min.	Typ.	Max.
a1	0.51			0.020		
B	1.39		1.65	0.055		0.065
b		0.5			0.020	
b1		0.25			0.010	
D			20			0.787
E		8.5			0.335	
e		2.54			0.100	
e3		15.24			0.600	
F			7.1			0.280
l			5.1			0.201
L		3.3			0.130	
Z	1.27		2.54	0.050		0.100

DIP14TLB

Information furnished is believed to be accurate and reliable. However, SGS-THOMSON Microelectronics assumes no responsibility for the consequences of use of such information nor for any infringement of patents or other rights of third parties which may result from its use. No licence is granted by implication or otherwise under any patent or patent rights of SGS-THOMSON Microelectronics. Specifications mentioned in this publication are subject to change without notice. This publication supersedes and replaces all information previously supplied. SGS-THOMSON Microelectronics products are not authorized for use as critical components in life support devices or systems without express written approval of SGS-THOMSON Microelectronics.

© 1997 SGS-THOMSON Microelectronics - All Rights Reserved

Purchase of I²C Components of SGS-THOMSON Microelectronics, conveys a license under the Philips I²C Patent. Rights to use these components in a I²C system, is granted provided that the system conforms to the I²C Standard Specifications as defined by Philips.

SGS-THOMSON Microelectronics GROUP OF COMPANIES

Australia - Brazil - Canada - China - France - Germany - Hong Kong - Italy - Japan - Korea - Malaysia - Malta - Morocco
The Netherlands - Singapore - Spain - Sweden - Switzerland - Taiwan - Thailand - United Kingdom - U.S.A.