

DATA SHEET



SAA7113H 9-bit video input processor

Product specification
File under Integrated Circuits, IC22

1999 Jul 01

9-bit video input processor**SAA7113H****CONTENTS**

1	FEATURES
2	APPLICATIONS
3	GENERAL DESCRIPTION
4	QUICK REFERENCE DATA
5	ORDERING INFORMATION
6	BLOCK DIAGRAM
7	PINNING
8	FUNCTIONAL DESCRIPTION
8.1	Analog input processing
8.2	Analog control circuits
8.3	Chrominance processing
8.4	Luminance processing
8.5	Synchronization
8.6	Clock generation circuit
8.7	Power-on reset and CE input
8.8	Multi-standard VBI data slicer
8.9	VBI-raw data bypass
8.10	Digital output port VPO7 to VPO0
8.11	RTCO output
8.12	RTS0, RTS1 terminals
9	BOUNDARY SCAN TEST
9.1	Initialization of boundary scan circuit
9.2	Device identification codes
10	LIMITING VALUES
11	THERMAL CHARACTERISTICS
12	CHARACTERISTICS
13	TIMING DIAGRAMS
14	APPLICATION INFORMATION
15	I ² C-BUS DESCRIPTION
15.1	I ² C-bus format
15.2	I ² C-bus detail
16	I ² C-BUS START SET-UP
17	PACKAGE OUTLINE
18	SOLDERING
18.1	Introduction to soldering surface mount packages
18.2	Reflow soldering
18.3	Wave soldering
18.4	Manual soldering
18.5	Suitability of surface mount IC packages for wave and reflow soldering methods
19	DEFINITIONS
20	LIFE SUPPORT APPLICATIONS
21	PURCHASE OF PHILIPS I ² C COMPONENTS

9-bit video input processor

SAA7113H

1 FEATURES

- Four analog inputs, internal analog source selectors, e.g. 4 × CVBS or 2 × Y/C or (1 × Y/C and 2 × CVBS)
- Two analog preprocessing channels in differential CMOS style for best S/N-performance
- Fully programmable static gain or automatic gain control for the selected CVBS or Y/C channel
- Switchable white peak control
- Two built-in analog anti-aliasing filters
- Two 9-bit video CMOS Analog-to-Digital Converters (ADCs), digitized CVBS or Y/C-signals are available on the VPO-port via I²C-bus control
- On-chip clock generator
- Line-locked system clock frequencies
- Digital PLL for horizontal sync processing and clock generation, horizontal and vertical sync detection
- Requires only one crystal (24.576 MHz) for all standards
- Automatic detection of 50 and 60 Hz field frequency, and automatic switching between PAL and NTSC standards
- Luminance and chrominance signal processing for PAL BGHI, PAL N, combination PAL N, PAL M, NTSC M, NTSC N, NTSC 4.43, NTSC-Japan and SECAM
- User programmable luminance peaking or aperture correction
- Cross-colour reduction for NTSC by chrominance comb filtering
- PAL delay line for correcting PAL phase errors
- Brightness Contrast Saturation (BCS) and hue control on-chip
- Real-time status information output (RTCO)
- Two multi functional real-time output pins controlled by I²C-bus
- Multi-standard VBI-data slicer decoding World Standard Teletext (WST), North-American Broadcast Text System (NABTS), closed caption, Wide Screen Signalling (WSS), Video Programming System (VPS), Vertical Interval Time Code (VITC) variants (EBU/SMPTE) etc.
- Standard ITU 656 YUV 4 : 2 : 2 format (8-bit) on VPO output bus
- Enhanced ITU 656 output format on VPO output bus containing:
 - active video
 - raw CVBS data for INTERCAST applications (27 MHz data rate)
 - decoded VBI data
- Boundary scan test circuit complies with the "IEEE Std. 1149.b1 - 1994" (ID-Code = 1 7113 02B)
- I²C-bus controlled (full read-back ability by an external controller, bit rate up to 400 kbits/s)
- Low power (<0.5 W), low voltage (3.3 V), small package (QFP44)
- Power saving mode by chip enable input
- 5 V tolerant digital I/O ports
- Detection of copy protected input signals according to the macrovision standard. Can be used to prevent unauthorized recording of pay-TV or video tape signals.



2 APPLICATIONS

- Notebook (low power consumption)
- PCMCIA card application
- AGP based graphics cards
- Image processing
- Video phone applications
- Intercast and PC teletext applications
- Security applications.

9-bit video input processor

SAA7113H

3 GENERAL DESCRIPTION

The 9-bit video input processor is a combination of a two-channel analog preprocessing circuit including source selection, anti-aliasing filter and ADC, an automatic clamp and gain control, a Clock Generation Circuit (CGC), a digital multi-standard decoder (PAL BGHI, PAL M, PAL N, combination PAL N, NTSC M, NTSC-Japan, NTSC N and SECAM), a brightness, contrast and saturation control circuit, a multi-standard VBI data slicer and a 27 MHz VBI data bypass; see Fig.1.

The pure 3.3 V (5 V compatible) CMOS circuit SAA7113H, analog front-end and digital video decoder, is a highly integrated circuit for desktop video applications.

The decoder is based on the principle of line-locked clock decoding and is able to decode the colour of PAL, SECAM and NTSC signals into CCIR-601 compatible colour component values. The SAA7113H accepts as analog inputs CVBS or S-video (Y/C) from TV or VTR sources. The circuit is I²C-bus controlled.

The integrated high performance multi-standard data slicer supports several VBI data standards:

- Teletext [WST (World Standard Teletext), CCST (Chinese teletext)] (625 lines)
- Teletext [US-WST, NABTS (North-American Broadcast Text System) and MOJI (Japanese teletext)] (525 lines)
- Closed caption [Europe, US (line 21)]
- Wide Screen Signalling (WSS)
- Video Programming Signal (VPS)
- Time codes (VITC EBU/SMPTE)
- HIGH-speed VBI data bypass for intercast application.

4 QUICK REFERENCE DATA

SYMBOL	PARAMETER	MIN.	TYP.	MAX.	UNIT
V _{DDD}	digital supply voltage	3.0	3.3	3.6	V
V _{DDA}	analog supply voltage	3.1	3.3	3.5	V
T _{amb}	operating ambient temperature	0	25	70	°C
P _{A+D}	analog and digital power dissipation	–	0.4	–	W

5 ORDERING INFORMATION

TYPE NUMBER	PACKAGE		
	NAME	DESCRIPTION	VERSION
SAA7113H	QFP44	plastic quad flat package; 44 leads (lead length 1.3 mm); body 10 × 10 × 1.75 mm	SOT307-2

9-bit video input processor

SAA7113H

6 BLOCK DIAGRAM

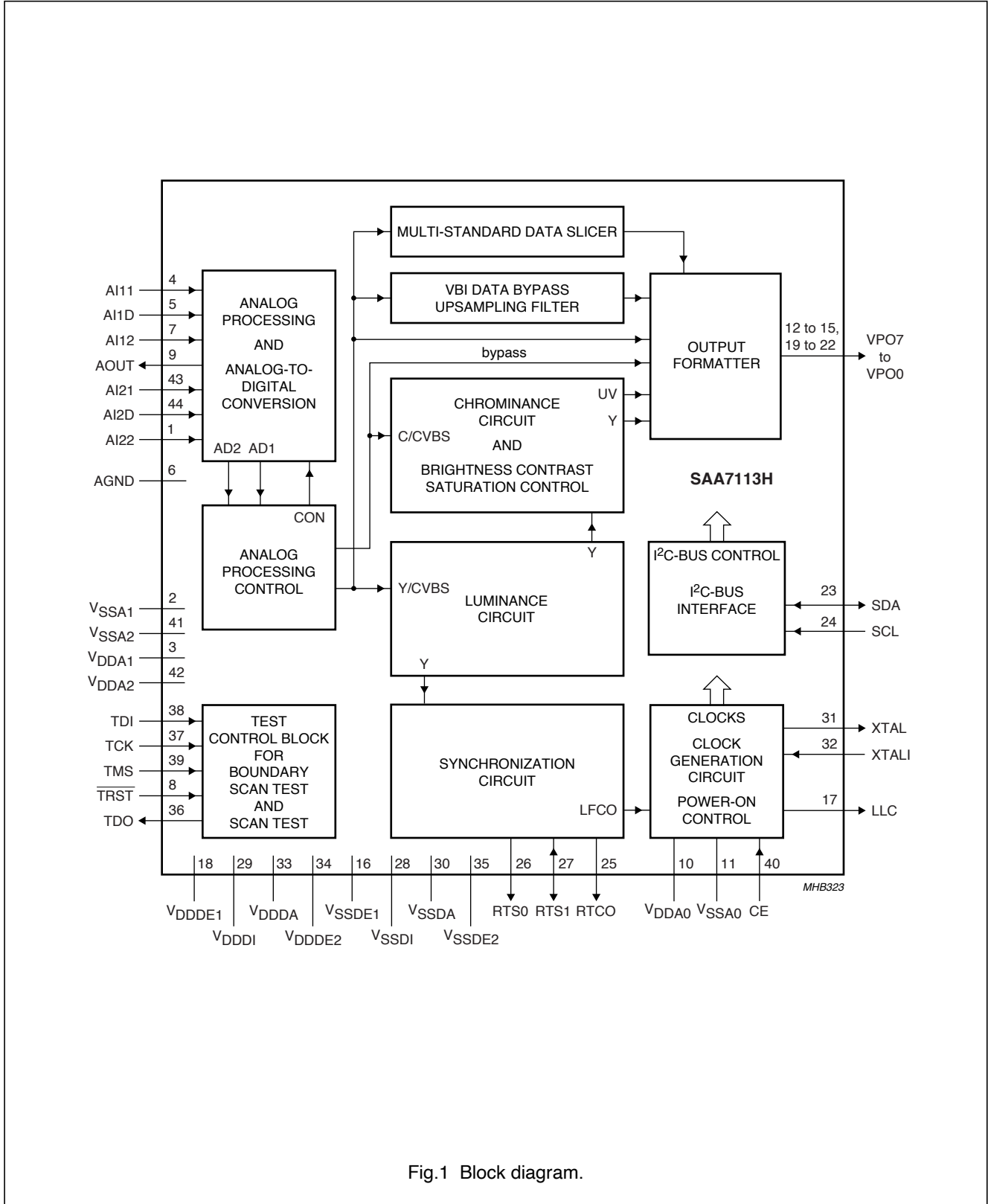

Fig.1 Block diagram.

9-bit video input processor

SAA7113H

7 PINNING

SYMBOL	PIN	I/O/P	DESCRIPTION
AI22	1	I	analog input 22
V _{SSA1}	2	P	ground for analog supply voltage channel 1
V _{DDA1}	3	P	positive supply voltage for analog channel 1 (+3.3 V)
AI11	4	I	analog input 11
AI1D	5	I	differential analog input for AI11 and AI12; has to be connected to ground via a capacitor; see application diagram of Fig.31
AGND	6	P	analog signal ground connection
AI12	7	I	analog input 12
TRST	8	I	test reset input (active LOW), for boundary scan test; notes 1, 2 and 3
AOUT	9	O	analog test output; for testing the analog input channels, 75 Ω termination possible
V _{DDA0}	10	P	positive supply voltage (+3.3 V) for internal Clock Generation Circuit (CGC)
V _{SSA0}	11	P	ground for internal clock generation circuit
VPO7 to VPO4	12 to 15	O	digital VPO-bus output signal; higher bits of the 8-bit output bus. The output data types of the VPO-bus are controlled via I ² C-bus registers LCR2 to LCR24; see Table 4. If I ² C-bus bit VIPB = 1, the higher bits of the digitized input signal are connected to these outputs, configured by the I ² C-bus control signals MODE3 to MODE0
V _{SSDE1}	16	P	ground 1 or digital supply voltage input E (external pad supply)
LLC	17	O	line-locked system clock output (27 MHz)
V _{DDDE1}	18	P	digital supply voltage E1 (external pad supply 1; +3.3 V)
VPO3 to VPO0	19 to 22	O	digital VPO-bus output signal; lower bits of the 8-bit output bus. The output data types of the VPO-bus are controlled via I ² C-bus registers LCR2 to LCR24; see Table 4. If I ² C-bus bit VIPB = 1, the lower bits of the digitized input signal are connected to these outputs, configured by the I ² C-bus control signals MODE3 to MODE0
SDA	23	I/O	serial data input/output (I ² C-bus) 5 V-compatible
SCL	24	I	serial clock input (I ² C-bus) 5 V-compatible
RTCO	25	(I/O)	real-time control output: contains information about actual system clock frequency, field rate, odd/even sequence, decoder status, subcarrier frequency and phase and PAL sequence (see external document "RTC Functional Description", available on request); the RTCO pin is enabled via I ² C-bus bit OERT; this pin is also used as an input pin for test purposes and has an internal pull-down resistor; do not connect any pull-up resistor to this pin
RTS0	26	(I/O)	real-time signal output 0: multi functional output, controlled by I ² C-bus bits RTSE03 to RTSE00; see Table 49. RTS0 is strapped during power-on or CE driven reset, defines which I ² C-bus slave address is used; 0 = 48H for write, 49H for read, external pull-down resistor of 3.3 kΩ is needed; 1 = 4AH for write, 4BH for read, default slave address (default, internal pull-up)
RTS1	27	I/O	real-time signal I/O terminal 1: multi functional output, controlled by I ² C-bus bit RTSE13 to RTSE10; see Table 50
V _{SSDI}	28	P	ground for internal digital core supply
V _{DDDI}	29	P	internal core supply (+3.3 V)
V _{SSDA}	30	P	digital ground for internal crystal oscillator
XTAL	31	O	second terminal of crystal oscillator; not connected if external clock signal is used

9-bit video input processor

SAA7113H

SYMBOL	PIN	I/O/P	DESCRIPTION
XTALI	32	I	input terminal for crystal oscillator or connection of external oscillator with CMOS compatible square wave clock signal
V _{DDDA}	33	P	digital positive supply voltage for internal crystal oscillator (+3.3 V)
V _{DDDE2}	34	P	digital supply voltage E2 (external pad supply 2; +3.3 V)
V _{SSDE2}	35	P	ground 2 for digital supply voltage input E (external pad supply)
TDO	36	O	test data output for boundary scan test; note 3
TCK	37	I	test clock for boundary scan test; note 3
TDI	38	I	test data input for boundary scan test; note 3
TMS	39	I	test mode select input for boundary scan test or scan test; note 3
CE	40	I	chip enable, 'sleep mode' with low power consumption if connected to ground (internal pull-up); internal reset sequence is generated when released
V _{SSA2}	41	P	ground for analog supply voltage channel 2
V _{DDA2}	42	P	positive supply voltage for analog channel 2 (+3.3 V)
AI21	43	I	analog input 21
AI2D	44	I	differential analog input for AI21 and AI22; has to be connected to ground via a capacitor; see application diagram of Fig.31

Notes

1. For board design without boundary scan implementation connect the $\overline{\text{TRST}}$ pin to ground.
2. This pin provides easy initialization of BST circuit. $\overline{\text{TRST}}$ can be used to force the Test Access Port (TAP) controller to the TEST_LOGIC_RESET state (normal operation) at once.
3. In accordance with the *IEEE1149.1* standard the pads TDI, TMS and $\overline{\text{TRST}}$ are input pads with an internal pull-up transistor and TDO is a 3-state output pad.

9-bit video input processor

SAA7113H

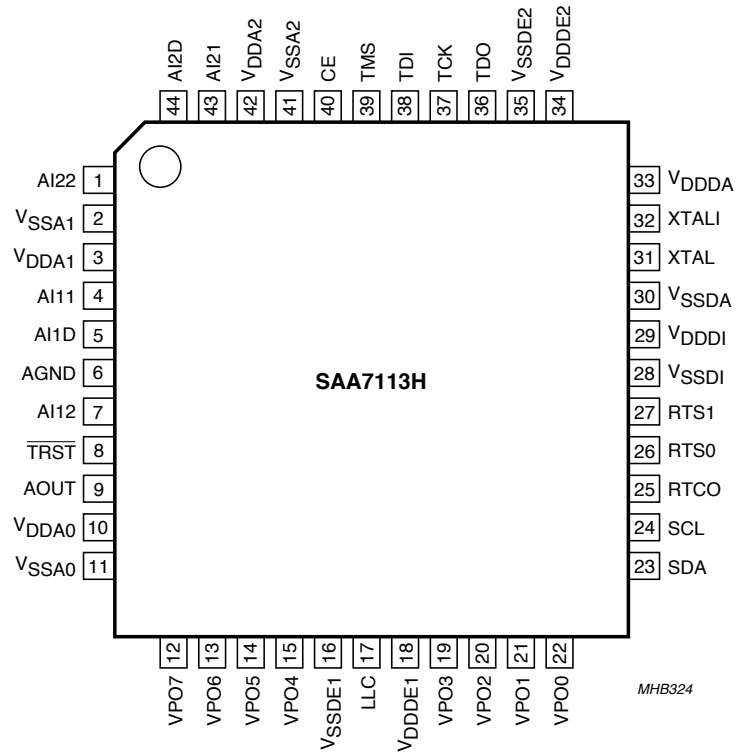

Fig.2 Pin configuration.

9-bit video input processor

SAA7113H

8 FUNCTIONAL DESCRIPTION

8.1 Analog input processing

The SAA7113H offers four analog signal inputs, two analog main channels with source switch, clamp circuit, analog amplifier, anti-alias filter and video 9-bit CMOS ADC; see Fig.6.

8.2 Analog control circuits

The anti-alias filters are adapted to the line-locked clock frequency via a filter control circuit. The characteristics are shown in Fig.3. During the vertical blanking period, gain and clamping control are frozen.

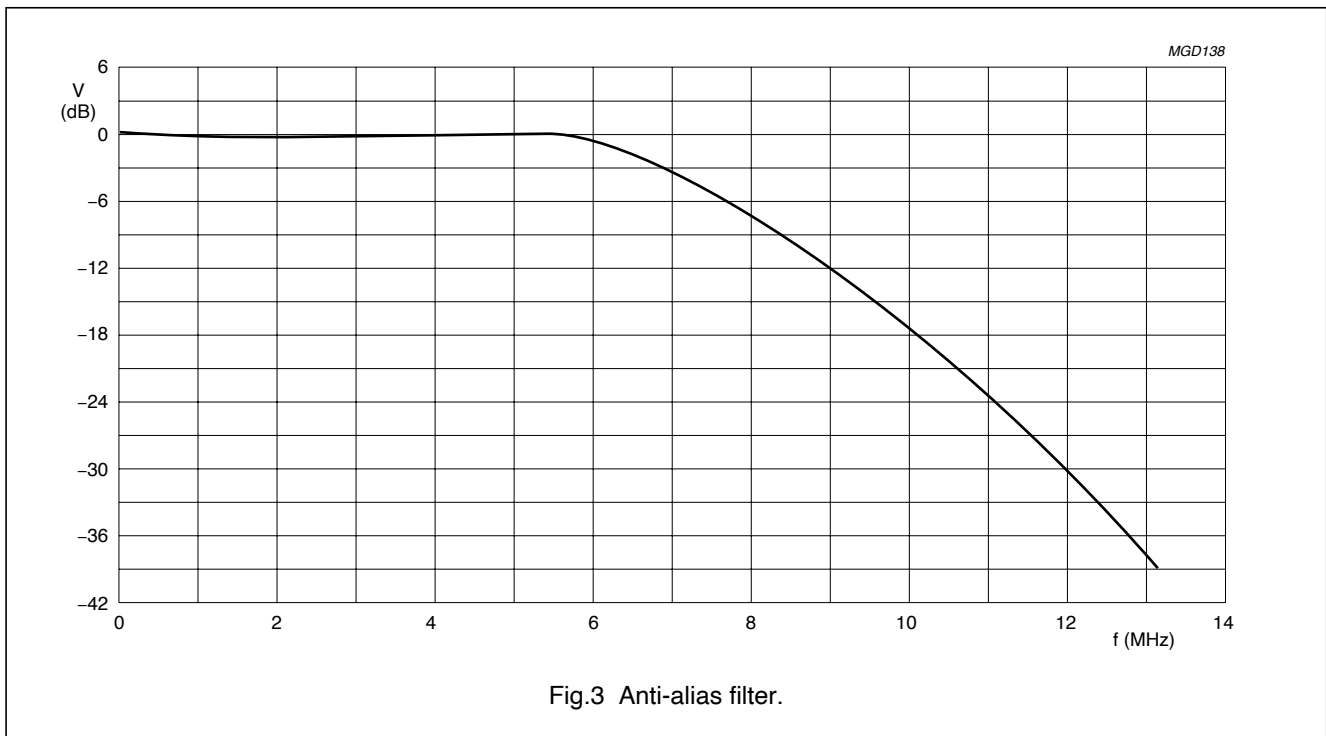

Fig.3 Anti-alias filter.

8.2.1 CLAMPING

The clamp control circuit controls the correct clamping of the analog input signals. The coupling capacitor is also used to store and filter the clamping voltage. An internal digital clamp comparator generates the information with respect to clamp-up or clamp-down. The clamping levels for the two ADC channels are fixed for luminance (120) and chrominance (256). Clamping time in normal use is set with the HCL pulse at the back porch of the video signal.

8.2.2 GAIN CONTROL

The gain control circuit receives (via the I²C-bus) the static gain levels for the two analog amplifiers or controls one of these amplifiers automatically via a built-in Automatic Gain Control (AGC) as part of the Analog Input Control (AICO). The AGC (automatic gain control for luminance) is used to amplify a CVBS or Y signal to the required signal

amplitude, matched to the ADCs input voltage range. The AGC active time is the sync bottom of the video signal.

Signal (white) peak control limits the gain at signal overshoots. The flow charts (see Figs 7 and 8) show more details of the AGC. The influence of supply voltage variation within the specified range is automatically eliminated by clamp and automatic gain control.

9-bit video input processor

SAA7113H

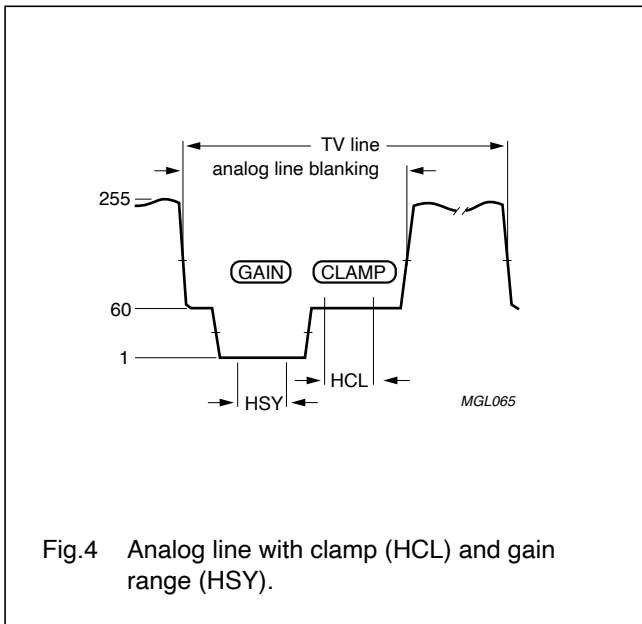

Fig.4 Analog line with clamp (HCL) and gain range (HSY).

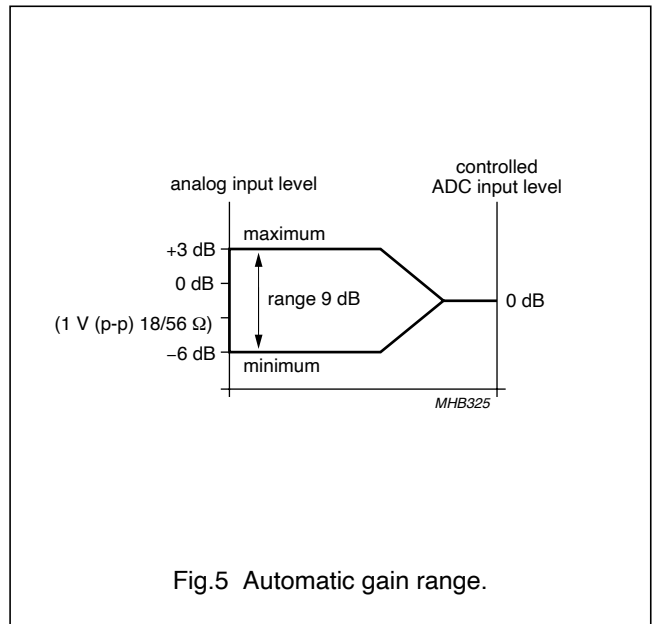

Fig.5 Automatic gain range.

9-bit video input processor

SAA7113H

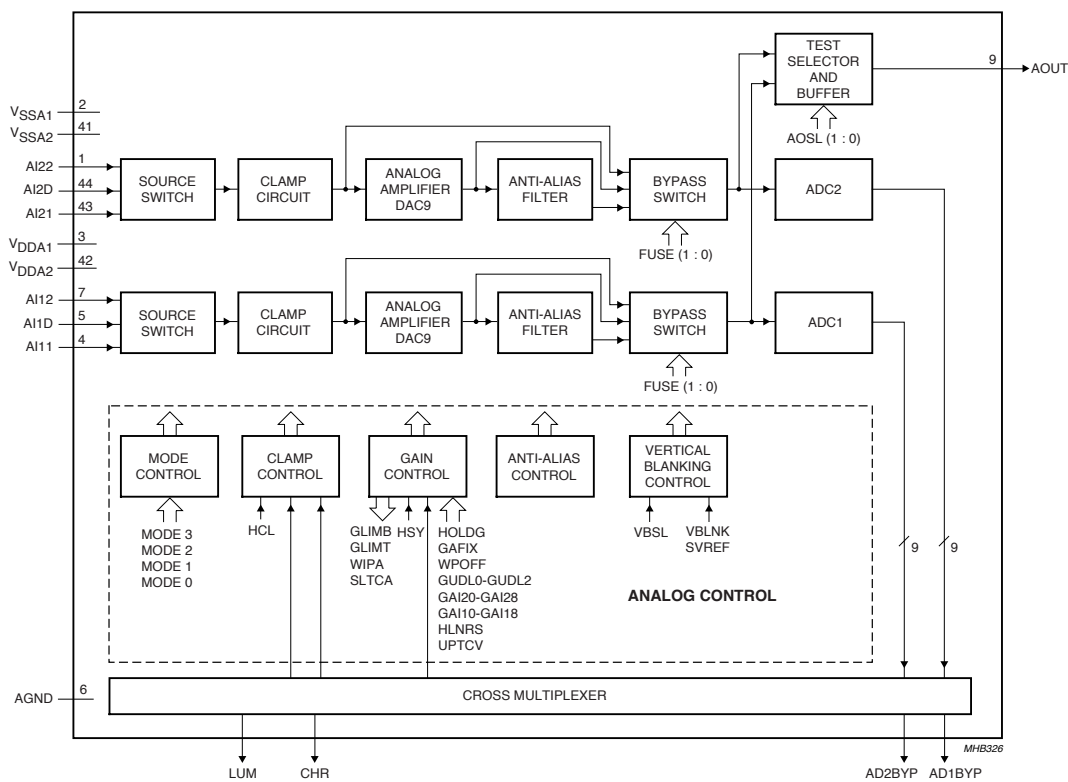
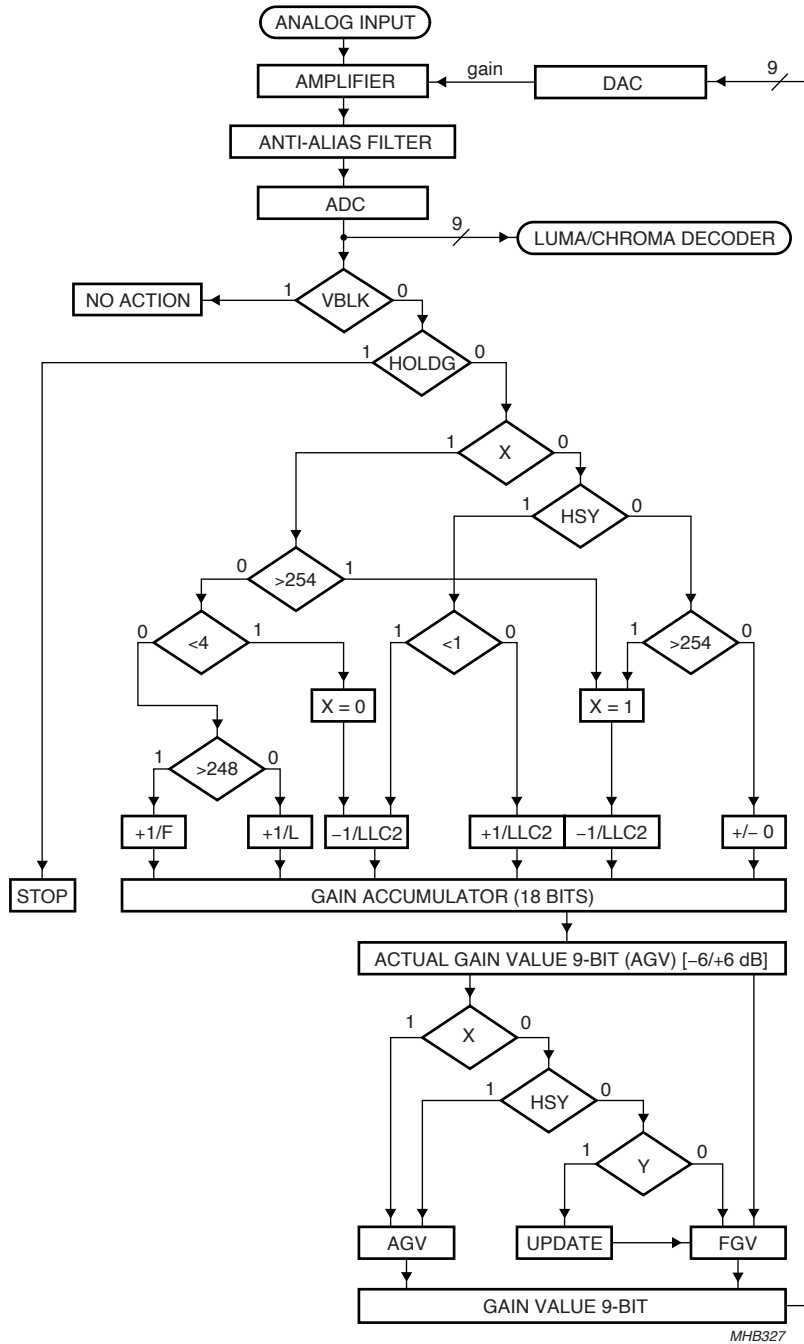

Fig.6 Analog input processing using the SAA7113H as differential front-end with 9-bit ADC.

MHB326

9-bit video input processor

SAA7113H



X = system variable; Y = (AGV - FGV) > GUDL; VBLK = vertical blanking pulse; HSY = horizontal sync pulse; AGV = actual gain value; FGV = frozen gain value.

Fig.7 Gain flow chart.

9-bit video input processor

SAA7113H

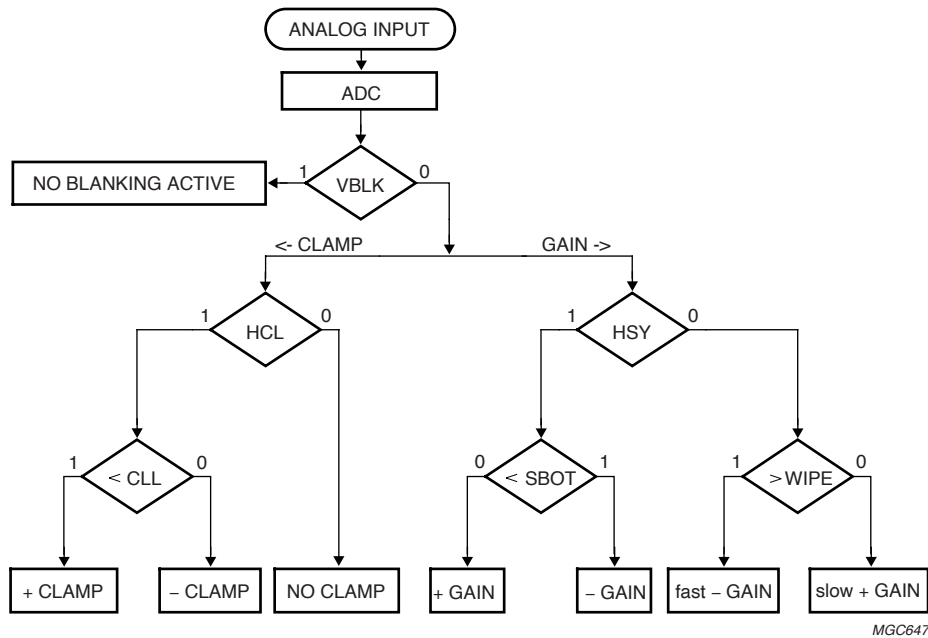

WIPE = white peak level (254); SBOT = sync bottom level (1); CLL = clamp level [60 Y (128 C)]; HSY = horizontal sync pulse; HCL = horizontal clamp pulse.

Fig.8 Clamp and gain flow.

8.3 Chrominance processing

The 9-bit chrominance signal is fed to the multiplication inputs of a quadrature demodulator, where two subcarrier signals from the local oscillator DTO1 are applied (0 and 90° phase relationship to the demodulator axis). The frequency is dependent on the present colour standard. The output signals of the multipliers are low-pass filtered (four programmable characteristics) to achieve the desired bandwidth for the colour difference signals (PAL, NTSC) or the 0 and 90° FM signals (SECAM).

The colour difference signals are fed to the Brightness/Contrast/Saturation block (BCS), which includes the following five functions:

- AGC (automatic gain control for chrominance PAL and NTSC)
- Chrominance amplitude matching (different gain factors for (R - Y) and (B - Y) to achieve CCIR-601 levels C_R and C_B for all standards)
- Chrominance saturation control

- Luminance contrast and brightness
- Limiting YUV to the values 1 (minimum) and 254 (maximum) to fulfil CCIR-601 requirements.

The SECAM-processing contains the following blocks:

- Baseband 'bell' filters to reconstruct the amplitude and phase equalized 0 and 90° FM signals
- Phase demodulator and differentiator (FM-demodulation)
- De-emphasis filter to compensate the pre-emphasized input signal, including frequency offset compensation (DB or DR white carrier values are subtracted from the signal, controlled by the SECAM switch signal).

The burst processing block provides the feedback loop of the chrominance PLL and contains:

- Burst gate accumulator
- Colour identification and killer
- Comparison nominal/actual burst amplitude (PAL/NTSC standards only)

9-bit video input processor

SAA7113H

- Loop filter chrominance gain control (PAL/NTSC standards only)
- Loop filter chrominance PLL (only active for PAL/NTSC standards)
- PAL/SECAM sequence detection, H/2-switch generation
- Increment generation for DTO1 with divider to generate stable subcarrier for non-standard signals.

The chrominance comb filter block eliminates crosstalk between the chrominance channels in accordance with the PAL standard requirements.

For NTSC colour standards the chrominance comb filter can be used to eliminate crosstalk from luminance to chrominance (cross-colour) for vertical structures. The comb filter can be switched off if desired. The embedded line delay is also used for SECAM recombination (cross-over switches).

The resulting signals are fed to the variable Y-delay compensation and the output interface, which contains the VPO output formatter and the output control logic, see Fig.10.

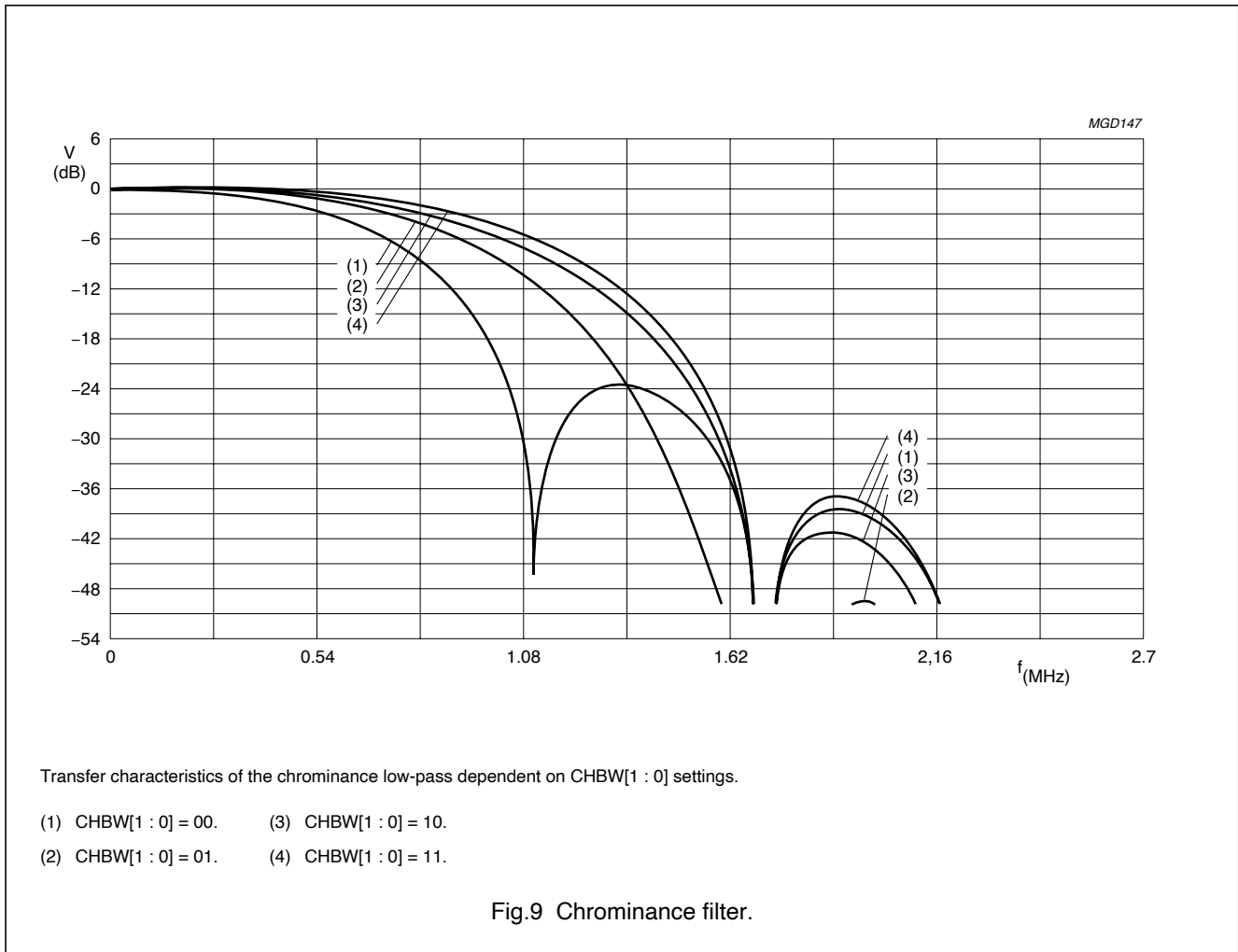

9-bit video input processor

SAA7113H

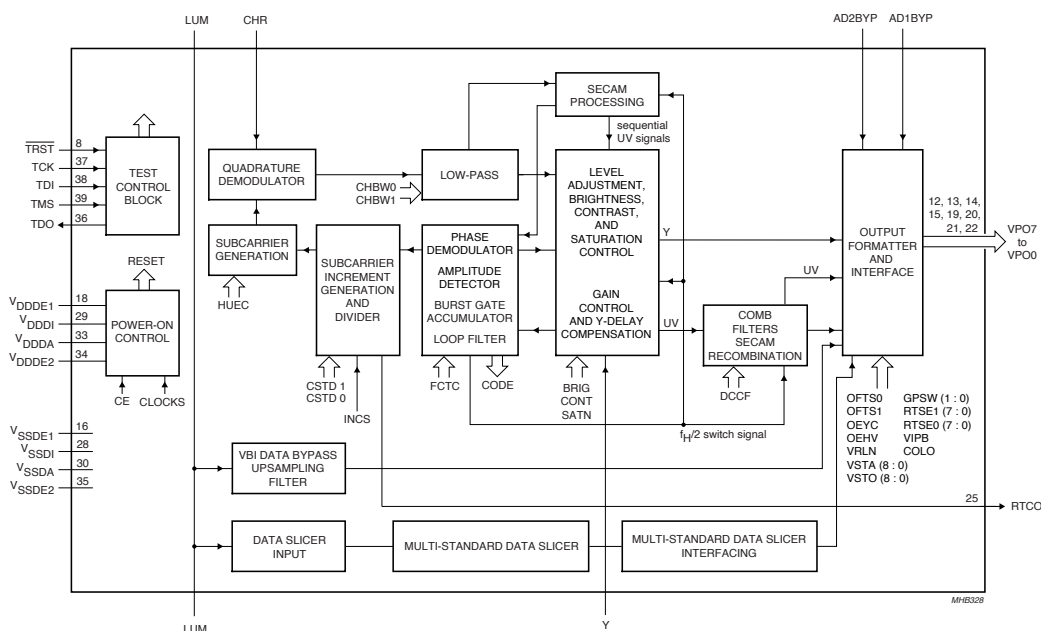

Fig.10 Chrominance circuit, text slicer, VBI-bypass, output formatting, power and test control.

9-bit video input processor

SAA7113H

8.4 Luminance processing

The 9-bit luminance signal, a digital CVBS format or a luminance format (S-VHS, HI8), is fed through a switchable prefilter. High frequency components are emphasized to compensate for loss. The following chrominance trap filter ($f_0 = 4.43$ or 3.58 MHz centre frequency set according to the selected colour standard) eliminates most of the colour carrier signal. It should be bypassed via I²C-bit BYPS (subaddress 09H, bit 7) for S-video (S-VHS, HI8) signals.

The high frequency components of the luminance signal can be peaked (control for sharpness improvement via I²C-bus subaddress 09H, see Table 36) in two band-pass filters with selectable transfer characteristic. This signal is then added to the original (unpeaked) signal. For the resulting frequency characteristics see Figs 11 to 18. A switchable amplifier achieves common DC amplification, because the DC gains are different in both chrominance trap modes. The improved luminance signal is fed to the BCS control located in the chrominance processing block, see Fig.19.

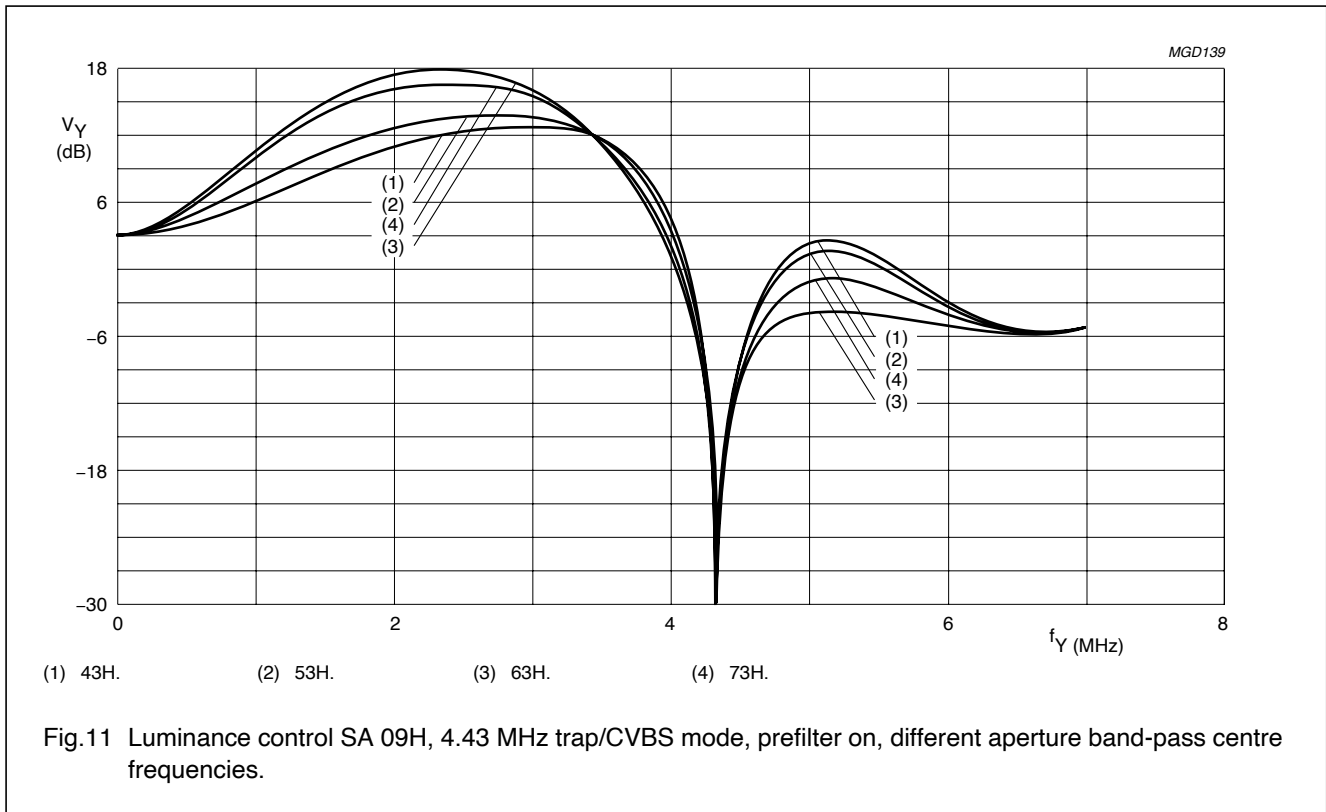
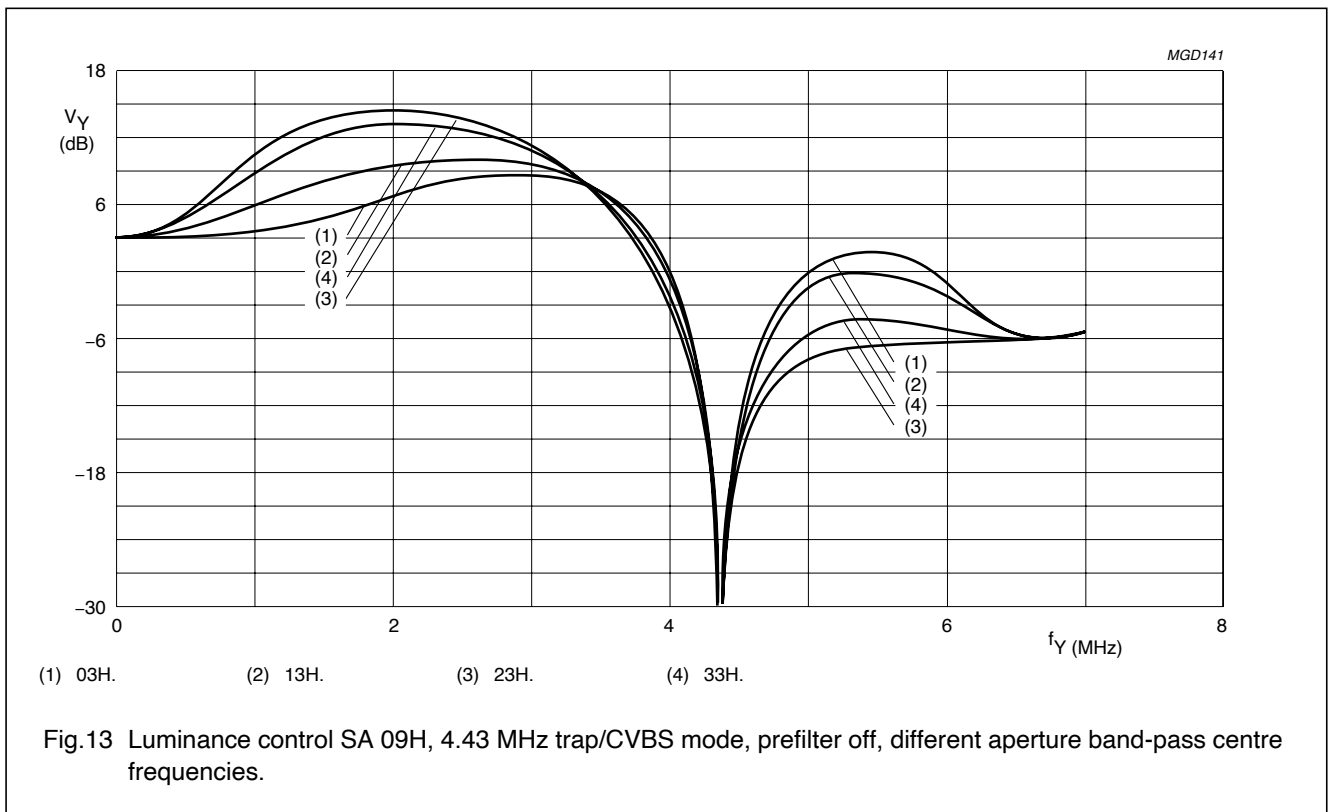
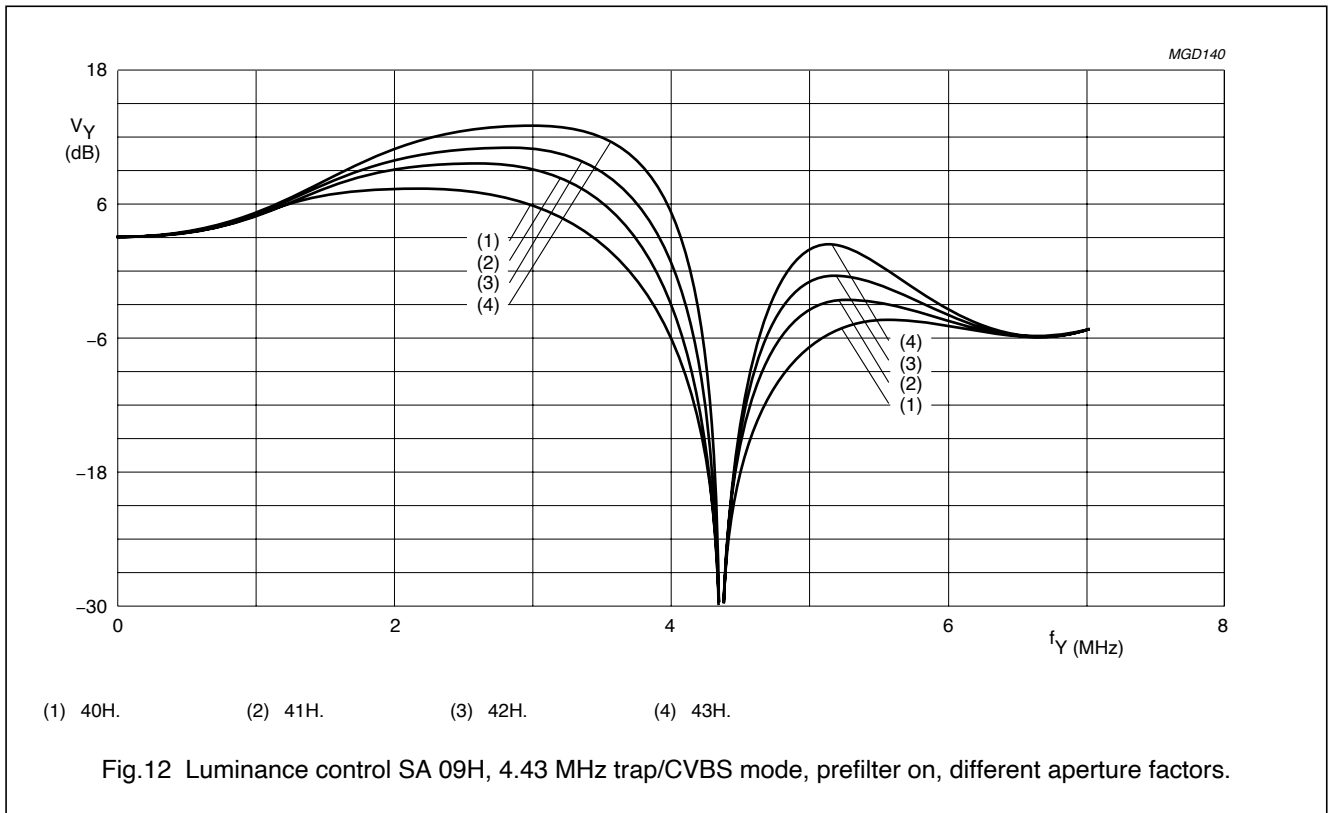

Fig.11 Luminance control SA 09H, 4.43 MHz trap/CVBS mode, prefilter on, different aperture band-pass centre frequencies.

9-bit video input processor

SAA7113H



9-bit video input processor

SAA7113H

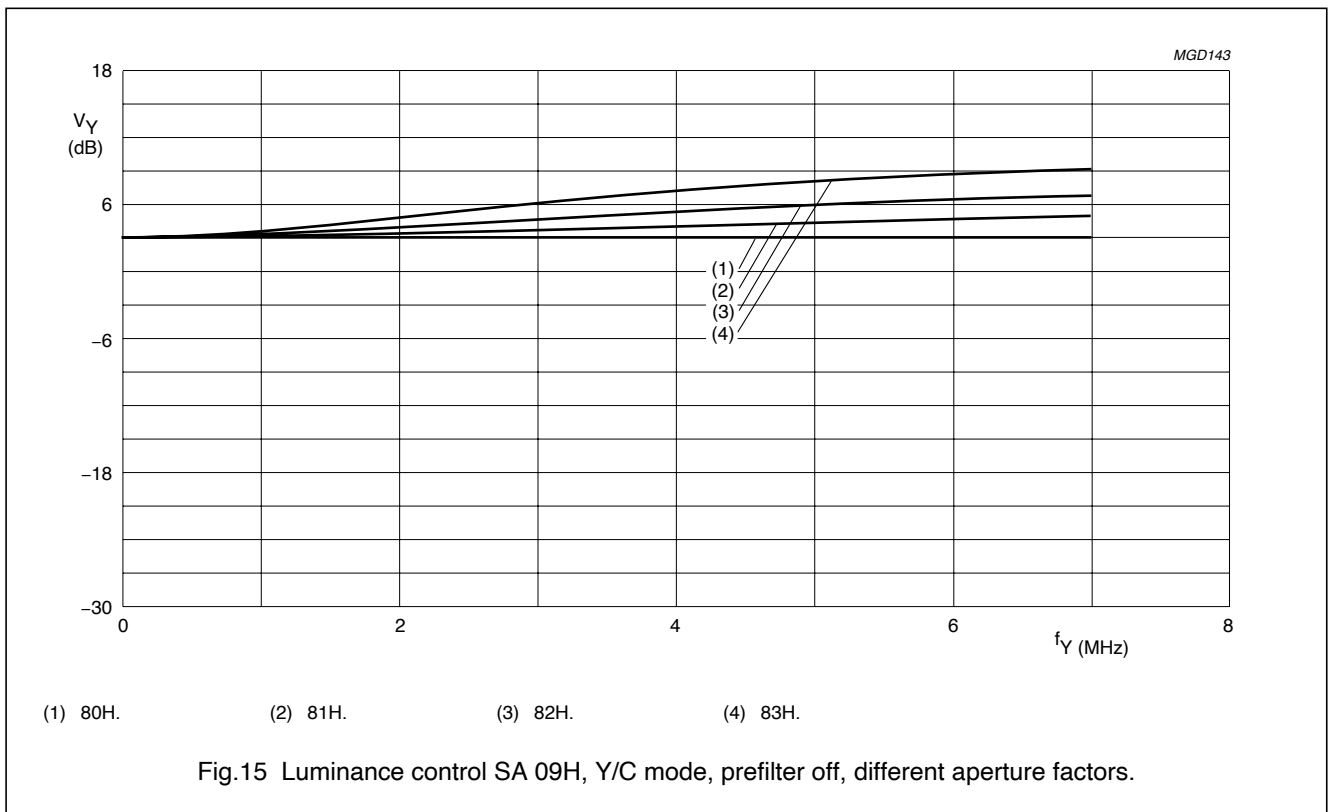
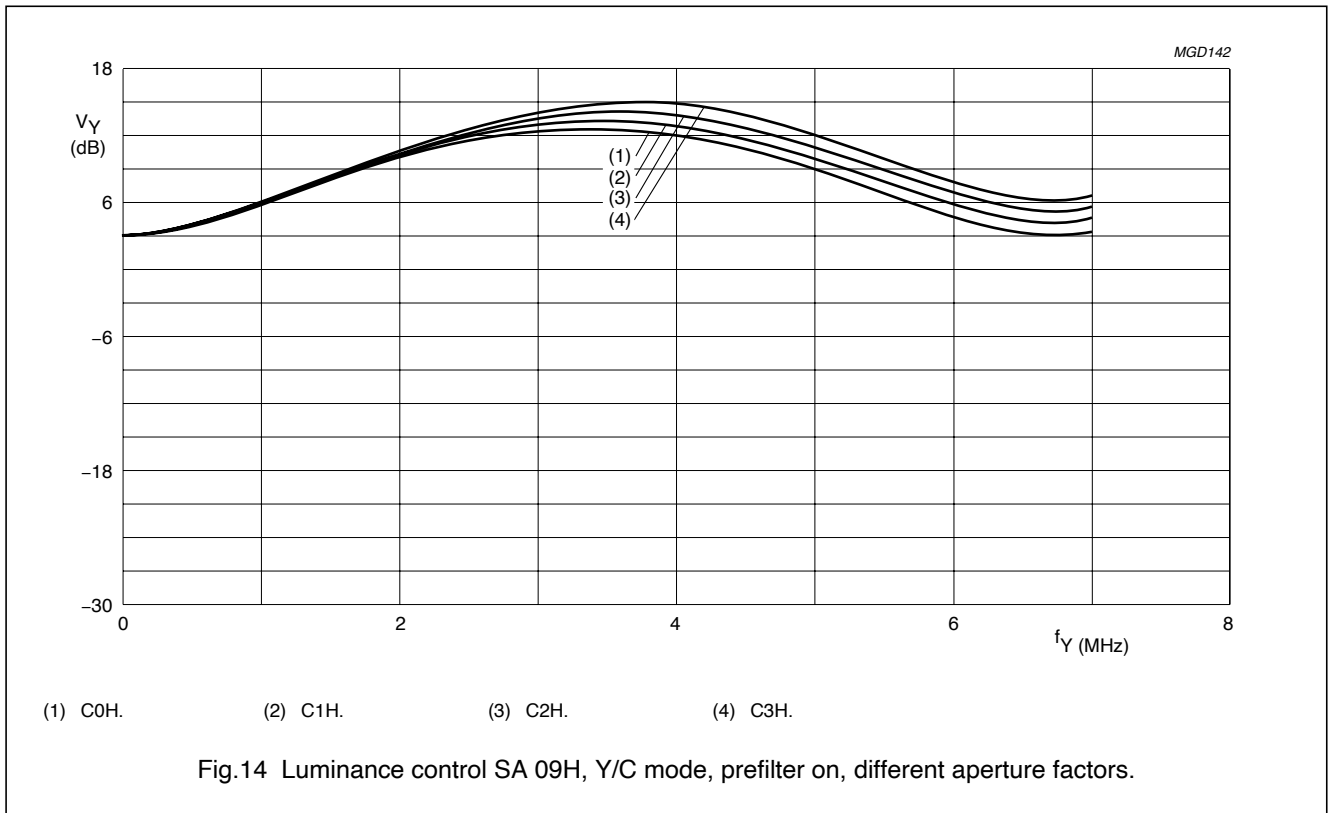

9-bit video input processor

SAA7113H

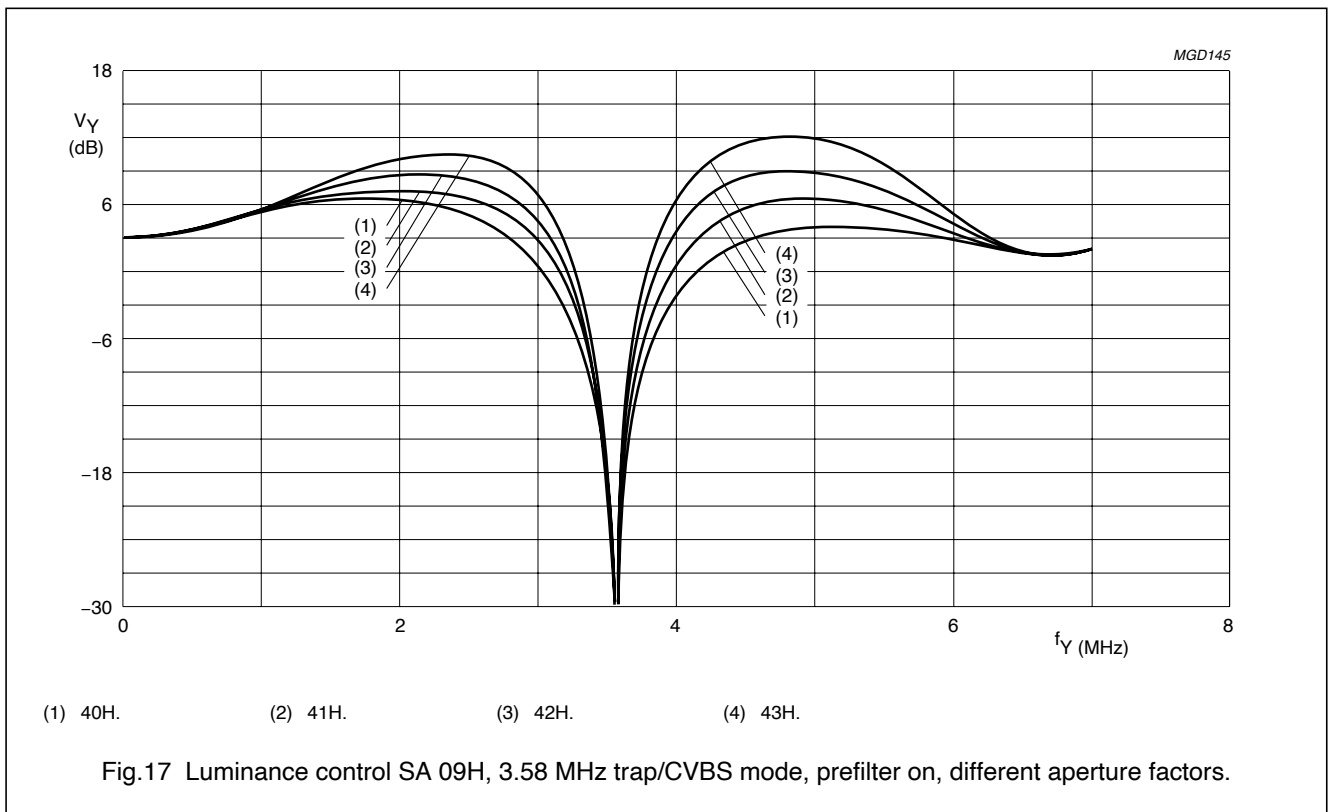
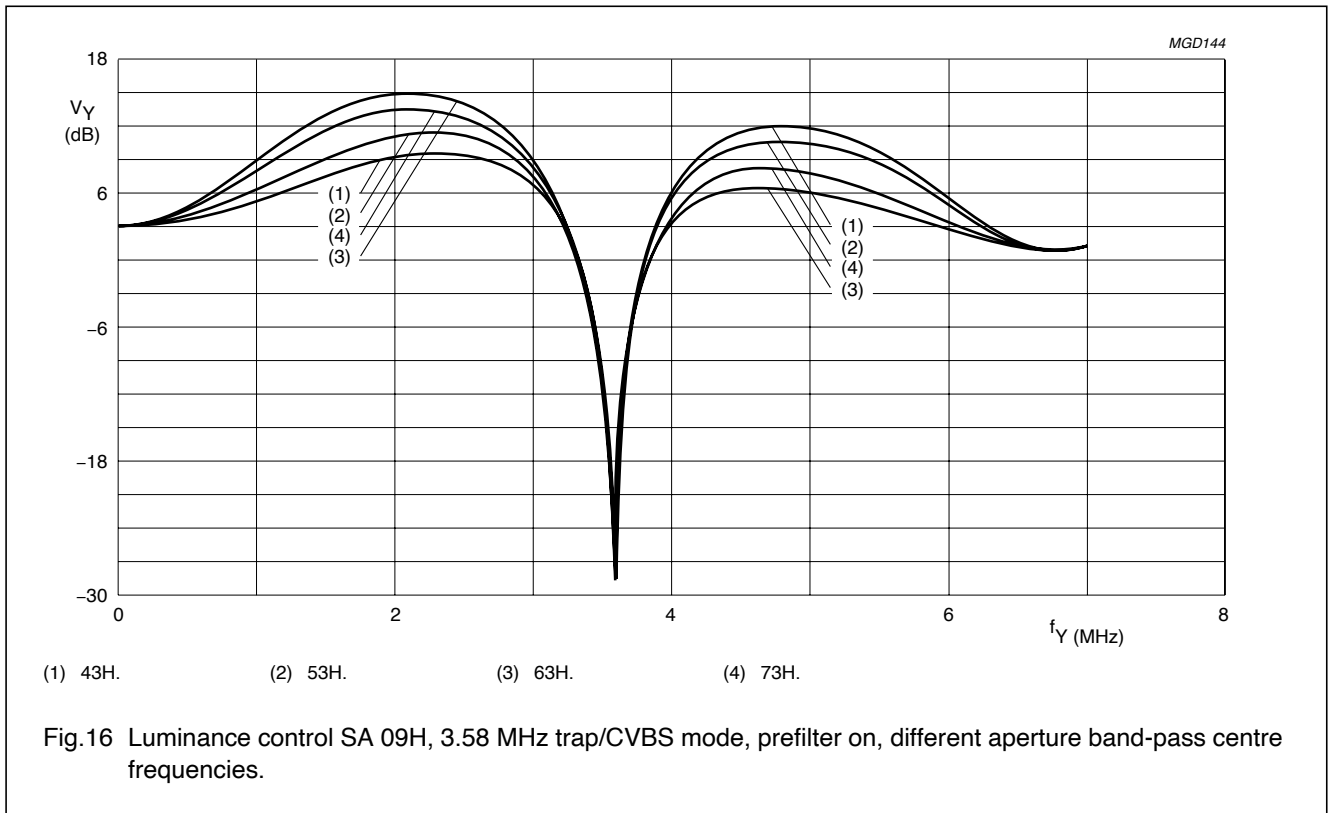

9-bit video input processor

SAA7113H

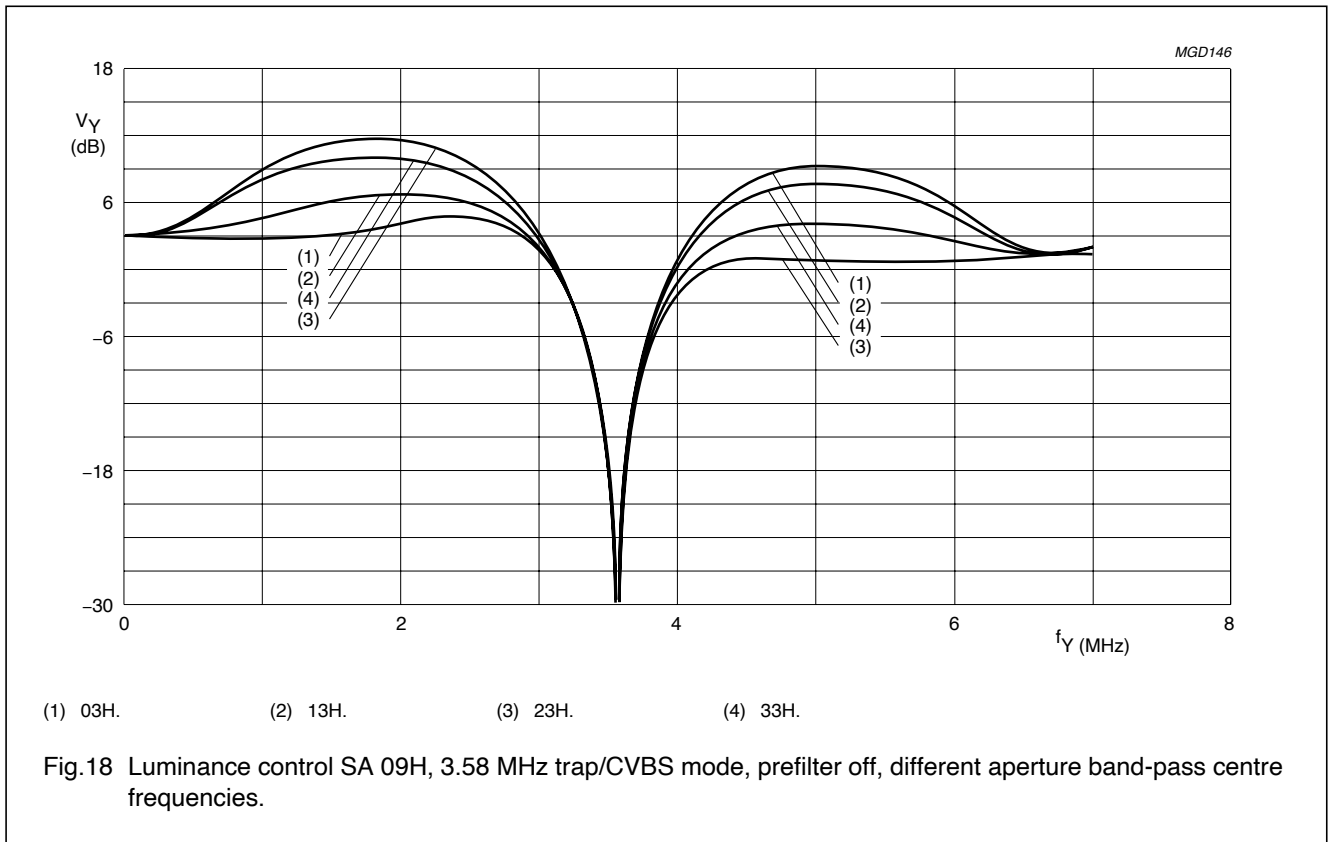

9-bit video input processor

SAA7113H

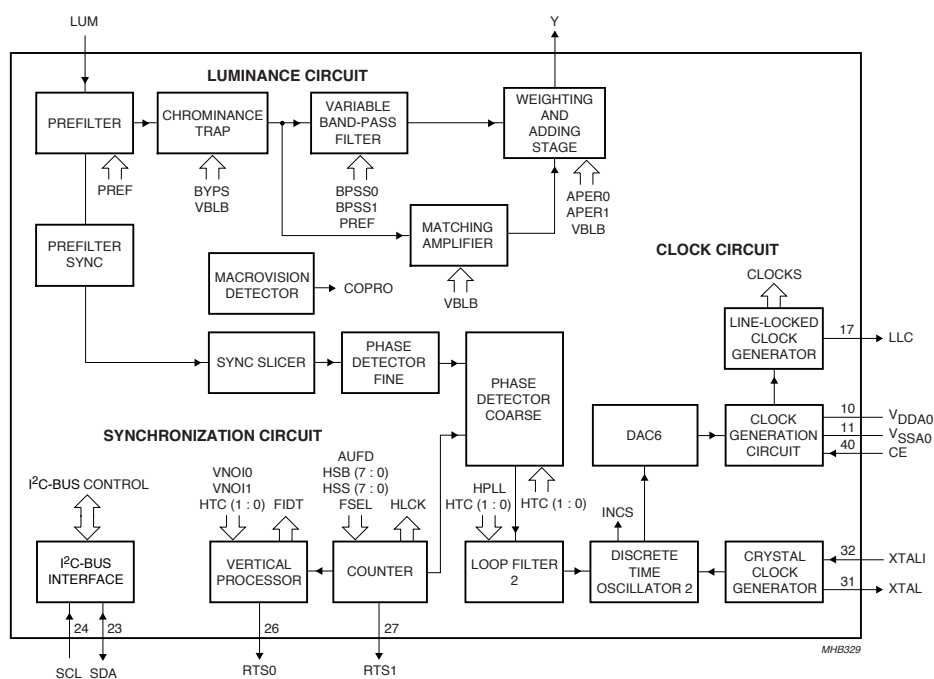

Fig.19 Luminance and sync processing.

9-bit video input processor

SAA7113H

8.5 Synchronization

The prefiltered luminance signal is fed to the synchronization stage. Its bandwidth is further reduced to 1 MHz in a low-pass filter. The sync pulses are sliced and fed to the phase detectors where they are compared with the sub-divided clock frequency. The resulting output signal is applied to the loop filter to accumulate all phase deviations. Internal signals (e.g. HCL and HSY) are generated in accordance with analog front-end requirements. The loop filter signal drives an oscillator to generate the line frequency control signal LLC, see Fig.19.

The detection of 'pseudo syncs' as part of the macrovision copy protection standard is also done within the synchronization circuit.

The result is reported as flag COPRO within the decoder status byte at subaddress 1FH.

8.6 Clock generation circuit

The internal CGC generates all clock signals required for the video input processor. The internal signal LFCO is a digital-to-analog converted signal provided by the horizontal PLL. It is the multiple of the line frequency [6.75 MHz = 429 × f_H (50 Hz) or 432 × f_H (60 Hz)].

Internally the LFCO signal is multiplied by a factor of 2 and 4 in the PLL circuit (including phase detector, loop filtering, VCO and frequency divider) to obtain the output clock signals. The rectangular output clocks have a 50% duty factor.

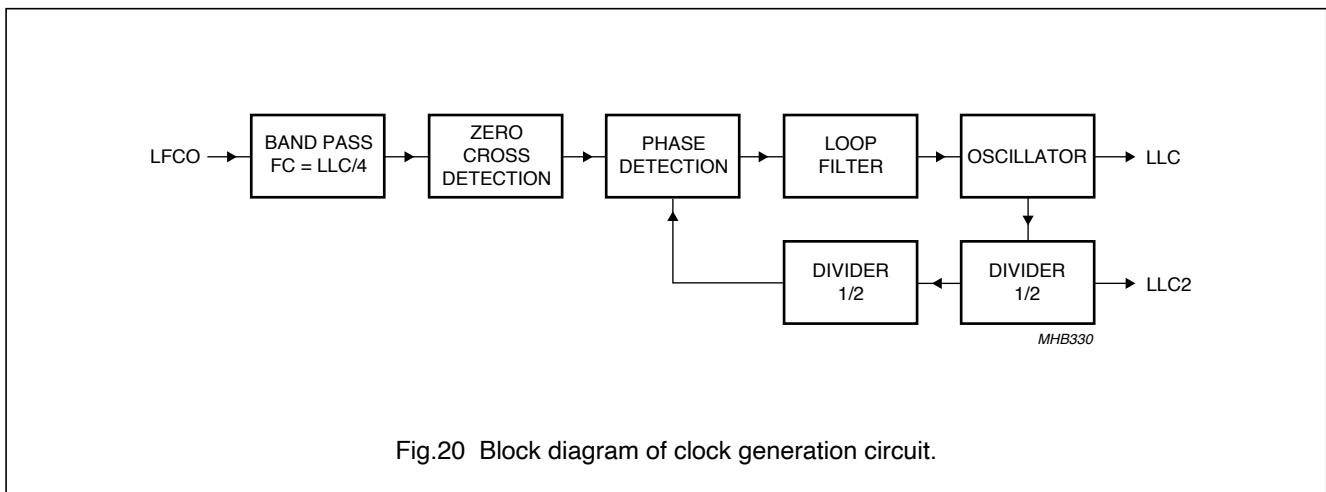

Fig.20 Block diagram of clock generation circuit.

Table 1 Clock frequencies

CLOCK	FREQUENCY (MHz)
XTAL	24.576
LLC	27
LLC2 (internal)	13.5
LLC4 (internal)	6.75
LLC8 (virtual)	3.375

8.7 Power-on reset and CE input

A missing clock, insufficient digital or analog V_{DDA0} supply voltages (below 2.8 V) will initiate the reset sequence; all outputs are forced to 3-state (see Fig.21).

It is possible to force a reset by pulling the Chip Enable (CE) to ground. After the rising edge of CE and sufficient power supply voltage, the outputs LLC and SDA return from 3-state to active, while RTS0, RTS1 and RTCO remain in 3-state and have to be activated via I²C-bus programming (see Table 2).

9-bit video input processor

SAA7113H

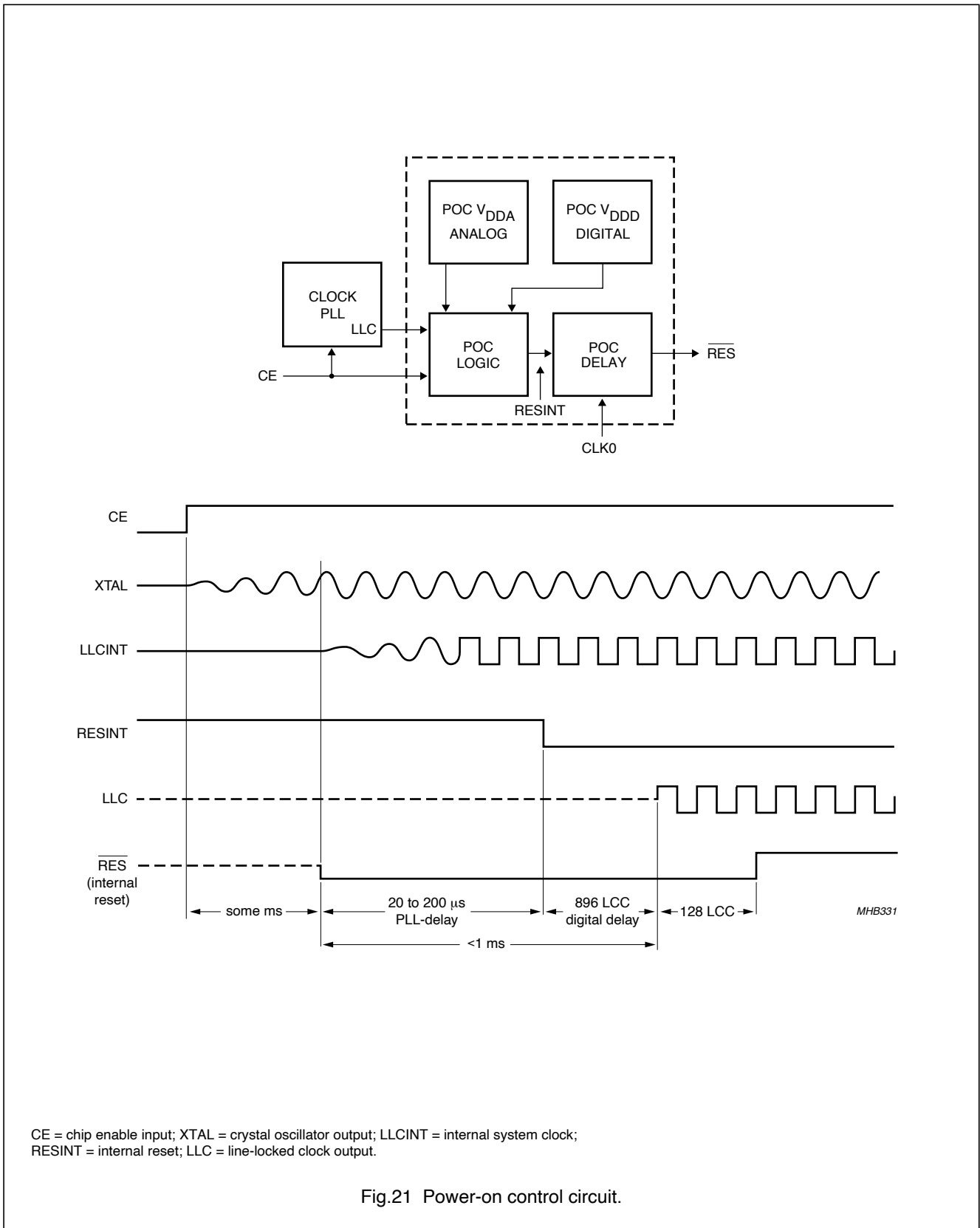

CE = chip enable input; XTAL = crystal oscillator output; LLCINT = internal system clock;
RESINT = internal reset; LLC = line-locked clock output.

Fig.21 Power-on control circuit.

9-bit video input processor

SAA7113H

Table 2 Power-on control sequence

INTERNAL POWER-ON CONTROL SEQUENCE	PIN OUTPUT STATUS	REMARKS
Directly after power-on asynchronous reset	VPO7 to VPO0, RTCO, RTS0, RTS1, SDA and LLC are in high-impedance state	direct switching to high-impedance for 20 to 200 ms
Synchronous reset sequence	LLC and SDA become active; VPO7 to VPO0, RTCO, RTS0 and RTS1 are held in high-impedance state	internal reset sequence
Status after power-on control sequence	VPO7 to VPO0, RTCO, RTS0 and RTS1 are held in high-impedance state	after power-on (reset sequence) a complete I ² C-bus transmission is required

8.8 Multi-standard VBI data slicer

The multi-standard data slicer is a Vertical Blanking Interval (VBI) and Full Field (FF) video data acquisition block. In combination with software modules the slicer acquires most existing formats of broadcast VBI and FF data.

The implementation and programming model of the multi-standard VBI data slicer is similar to the text slicer built in the "Multimedia Video Data Acquisition Circuit SAA5284".

The circuitry recovers the actual clock phase during the clock-run-in-period, slices the data bits with the selected data rate, and groups them into bytes. The clock frequency, signals source, field frequency and accepted error count must be defined via the I²C-bus in subaddress 40H, AC1: bits D7 to D4.

Several standards can be selected per VBI line. The supported VBI data standards are described in Table 3.

The programming of the desired standards is done via I²C-bus subaddresses 41H to 57H (LCR2[7 : 0] to LCR24[7 : 0]); see detailed description in Chapter 8.10. To adjust the slicers processing to the signals source, there are offsets in horizontal and vertical direction available via the I²C-bus in subaddresses 5BH (bits 2 to 0), 59H (HOFF10 to HOFF0) and 5BH (bit 4), 5AH (VOFF8 to VOFF0). The formatting of the decoded VBI data is done within the output interface to the VPO-bus. For a detailed description of the sliced data format see Table 17.

Table 3 Supported VBI standards

STANDARD TYPE	DATA RATE (Mbits/s)	FRAMING CODE	FC WINDOW	HAM CHECK
Teletext EuroWST, CCST	6.9375	27H	WST625	always
European closed caption	0.500	001	CC625	
VPS	5	9951H	VPS	
Wide screen signalling bits	5	1E3C1FH	WSS	
US teletext (WST)	5.7272	27H	WST525	always
US closed caption (line 21)	0.503	001	CC525	
Teletext	6.9375	programmable	general text	optional
VITC/EBU time codes (Europe)	1.8125	programmable	VITC625	
VITC/SMPTE time codes (USA)	1.7898	programmable	VITC625	
US NABTS	5.7272	programmable	NABTS	optional
MOJI (Japanese)	5.7272	programmable (A7H)	Japtext	
Japanese format switch (L20/22)	5	programmable		

9-bit video input processor

SAA7113H

8.9 VBI-raw data bypass

For a 27 MHz VBI-raw data bypass the digitized CVBS signal is upsampled after AD-conversion. Suppressing of the back folded CVBS frequency components after upsampling is achieved by an interpolation filter; see Fig.22.

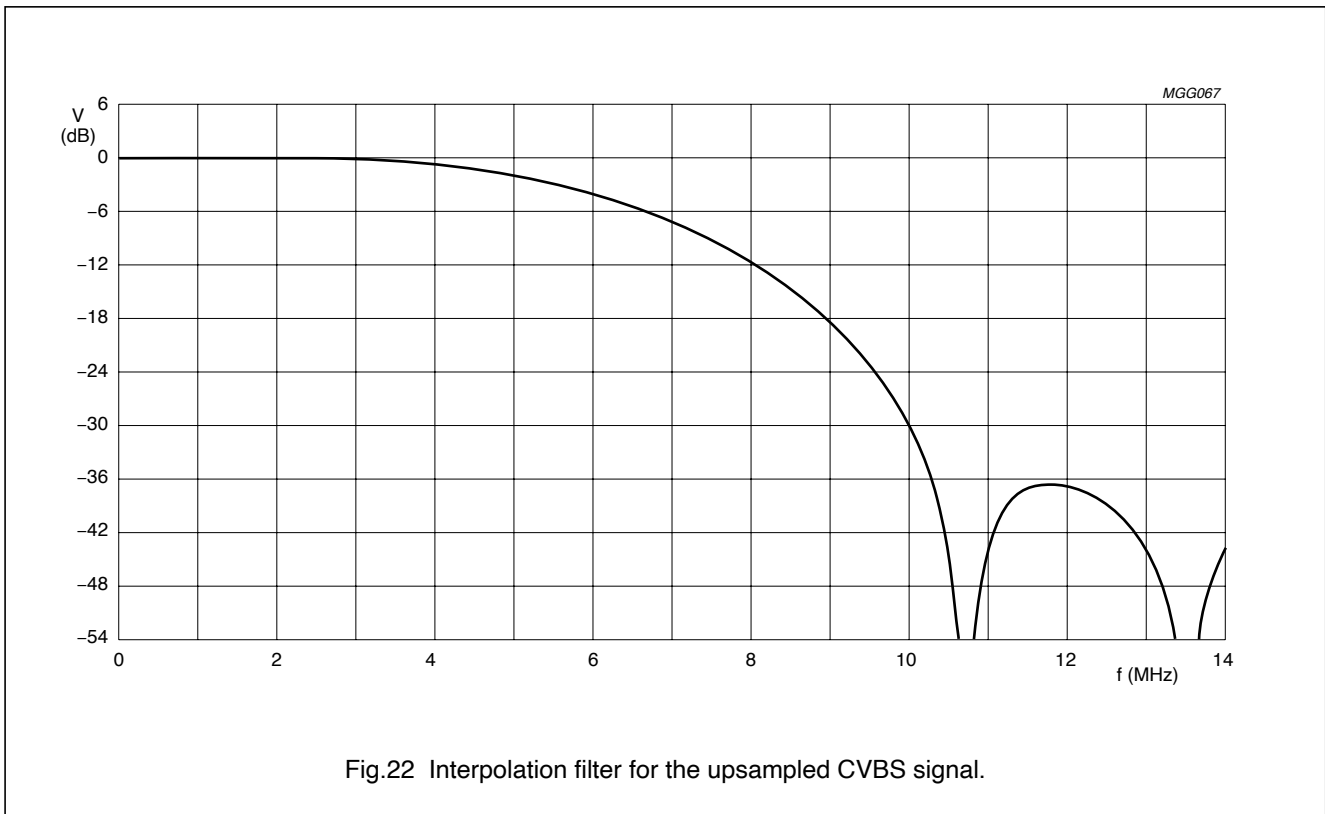

9-bit video input processor

SAA7113H

8.10 Digital output port VPO7 to VPO0

The 8-bit VPO-bus can carry 16 data types in three different formats, selectable by the control registers LCR2 to LCR24 (see also Chapter 15, subaddresses 41H to 57H).

Table 4 VPO-bus data formats and types

DATA TYPE NUMBER	DATA FORMAT	DATA TYPE	NAME	NUMBER OF VALID BYTES SENT PER LINE
0	sliced	teletext EuroWST, CCST	WST625	88
1	sliced	European closed caption	CC625	8
2	sliced	VPS	VPS	56
3	sliced	Wide screen signalling bits	WSS	32
4	sliced	US teletext (WST)	WST525	72
5	sliced	US closed caption (line 21)	CC525	8
6	YUV 4 : 2 : 2	video component signal, VBI region	test line	1440
7	raw	oversampled CVBS data	intercast	programmable
8	sliced	teletext	general text	88
9	sliced	VITC/EBU time codes (Europe)	VITC625	26
10	sliced	VITC/SMPTE time codes (USA)	VITC625	26
11	reserved	reserved	–	–
12	sliced	US NABTS	NABTS	72
13	sliced	MOJI (Japanese)	Japtext	74
14	sliced	Japanese format switch (L20/22)	JFS	56
15	YUV 4 : 2 : 2	video component signal, active video region	active video	1440

Note

1. The number of valid bytes per line can be less for the sliced data format if standard not recognized (wrong standard or poor input signal).

For each LCR value from 2 to 23 the data type can be programmed individually. LCR2 to LCR23 refer to line numbers. The selection in LCR24 values is valid for the rest of the corresponding field. The upper nibble contains the value for field 1 (odd), the lower nibble for field 2 (even). The relationship between LCR values and line numbers can be adjusted via VOFF8 to VOFF0 (located in subaddresses 5BH, bit 4 and 5AH, bits 7 to 0).

The recommended values are 07H for 50 Hz sources and 0AH for 60 Hz sources, to accommodate line number conventions as used for PAL, SECAM and NTSC standards; see Tables 8 to 11.

9-bit video input processor

SAA7113H

Some details about data types:

- **Active video** (data type 15) component YUV 4 : 2 : 2 signal, 720 active pixels per line. Format and nominal levels are given in Fig.23 and Table 13.
- **Test line** (data type 6), is similar to decoded YUV-data as in active video, with two exceptions:
 - vertical filter (chrominance comb filter for NTSC standards, PAL-phase-error correction) within the chrominance processing is disabled
 - peaking and chrominance trap are bypassed within the luminance processing, if I²C-bus bit VBLB is set. This data type is defined for future enhancements; it could be activated for lines containing standard test signals within the vertical blanking period; currently the most sources do not contain test lines.

This data type is available only in lines with VREF = 0, see I²C-bus detail section, Table 45.
Format and nominal levels are given in Fig.23 and Table 13.
- **Raw samples** (data type 7) oversampled CVBS-signal for intercast applications; the data rate is 27 MHz. The horizontal range is programmable via HSB7 to HSB0, HSS7 to HSS0 and HDEL1 to HDEL0;

see I²C-bus section subaddresses 06H, 07H and 10H and Tables 33, 34 and 46.
Format and nominal levels are given in Fig.24 and Table 15.

- **Sliced data** (various standards, data types 0 to 5 and 8 to 14).
The format is given in Table 17.

The data type selections by LCR are overruled by setting VIPB (subaddress 11H bit 1) to logic 1. This setting is mainly intended for device production tests. The VPO-bus carries the upper or lower 8 bits of the two ADCs depending on the ADLSB (subaddress 13H bit 7) setting. The output configuration is done via MODE3 to MODE0 settings (subaddress 02H bits 3 to 0, see Table 27). If the YC-mode is selected, the VPO-bus carries the multiplexed output signals of both ADCs, in CVBS-mode the output of only one ADC. No timing reference codes are generated in this mode.

Note: The LSBs (bit 0) of the ADCs are available on pins RTS0 or RTS1. See Chapter 15, subaddress 12H for details.

The SAV/EAV timing reference codes define start and end of valid data regions.

Table 5 SAV/EAV format

BIT 7	BIT 6 (F)	BIT 5 (V)	BIT 4 (H)	BIT 3 (P3)	BIT 2 (P2)	BIT 1 (P1)	BIT 0 (P0)
1	field bit 1st field: F = 0; 2nd field: F = 1; for vertical timing see Tables 6 and 7	vertical blanking bit VBI: V = 1; active video: V = 0; for vertical timing see Tables 6 and 7	H = 0 in SAV; H = 1 in EAV	reserved; evaluation not recommended (protection bits according to ITU 656)			

The generation of the H-bit and consequently the timing of SAV/EAV corresponds to the selected data format. H = 0 during active data region. For all data formats excluding data type 7 (raw data), the length of the active data region is 1440 LLC. For the YUV 4 : 2 : 2 formats (data types 15 and 6) every clock cycle within this range contains valid data, see Table 13.

The sliced data stream (various standards, data types 0 to 5 and 8 to 14; see Table 17) contains also invalid cycles marked as 00H.

The length of the raw data region (data type 7) is programmable via HSB7 to HSB0 and HSS7 to HSS0 (subaddresses 06H and 07H; see Fig.24).

During horizontal blanking period between EAV and SAV the ITU-blanking code sequence '-80-10-80-10-...' is transmitted.

The position of the F-bit is constant according to ITU 656 (see Tables 6 and 7).

The V-bit can be generated in four different ways (see Tables 6 and 7) controlled via OFTS1 and OFTS0 (subaddress 10H, bits 7 and 6), VRLN (subaddress 10H, bit 3) and LCR2 to LCR24 (subaddresses 41H to 57H).

F and V bits change synchronously with the EAV code.

9-bit video input processor

SAA7113H

Table 6 525 lines/60 Hz vertical timing

LINE NUMBER	F (ITU 656)	V			OFTS1 = 1; OFTS0 = 0
		OFTS1 = 0; OFTS0 = 0 (ITU 656)	OFTS1 = 0; OFTS0 = 1		
			VRLN = 0	VRLN = 1	
1 to 3	1	1	1	1	according to selected data type via LCR2 to LCR24 (subaddresses 41H to 57H): data types 0 to 14: V = 1; data type 15: V = 0
4 to 19	0	1	1	1	
20	0	0	1	1	
21	0	0	1	0	
22 to 261	0	0	0	0	
262	0	0	1	0	
263	0	0	1	1	
264 and 265	0	1	1	1	
266 to 282	1	1	1	1	
283	1	0	1	1	
284	1	0	1	0	
285 to 524	1	0	0	0	
525	1	0	1	0	

Table 7 625 lines/50 Hz vertical timing

LINE NUMBER	F (ITU 656)	V			OFTS1 = 1; OFTS0 = 0
		OFTS1 = 0; OFTS0 = 0 (ITU 656)	OFTS1 = 0; OFTS0 = 1		
			VRLN = 0	VRLN = 1	
1 to 22	0	1	1	1	according to selected data type via LCR2 to LCR24 (subaddresses 41H to 57H): data types 0 to 14: V = 1; data type 15: V = 0
23	0	0	1	0	
24 to 309	0	0	0	0	
310	0	0	1	0	
311 and 312	0	1	1	1	
313 to 335	1	1	1	1	
336	1	0	1	0	
337 to 622	1	0	0	0	
623	1	0	1	0	
624 and 625	1	1	1	1	

Table 8 Relationship of LCR to line numbers in 525 lines/60 Hz systems (part 1)

VERTICAL LINE OFFSET VOFF8 TO VOFF0 = 00AH; HORIZONTAL PIXEL OFFSET HOFF10 TO HOFF0 = 354H, FOFF = 1, FISET = 1																
Line number (1st field)	519	520	521	522	523	524	525	1	2	3	4	5	6	7	8	9
	active video						equalization pulses			serration pulses			equalization pulses			
Line number (2nd field)	257	258	259	260	261	262	263	264	265	266	267	268	269	270	271	272
	active video						equalization pulses			serration pulses			equalization pulses			
LCR (VOFF = 00AH; HOFF = 354H; FOFF = 1; FISET = 1)	24						2		3	4	5	6	7	8	9	

Table 9 Relationship of LCR to line numbers in 525 lines/60 Hz systems (part 2)

VERTICAL LINE OFFSET VOFF8 TO VOFF0 = 00AH; HORIZONTAL PIXEL OFFSET HOFF10 TO HOFF0 = 354H, FOFF = 1, FISET = 1														
Line number (1st field)	10	11	12	13	14	15	16	17	18	19	20	21	22	23
	nominal VBI-lines F1												active video	
Line number (2nd field)	273	274	275	276	277	278	279	280	281	282	283	284	285	286
	nominal VBI-lines F2												active video	
LCR (VOFF = 00AH; HOFF = 354H; FOFF = 1; FISET = 1)	10	11	12	13	14	15	16	17	18	19	20	21	22	23

Table 10 Relationship of LCR to line numbers in 625 lines/50 Hz systems (part 1)

VERTICAL LINE OFFSET VOFF8 TO VOFF0 = 007H; HORIZONTAL PIXEL OFFSET HOFF10 TO HOFF0 = 354H, FOFF = 1, FISET = 0										
Line number (1st field)	621	622	623	624	625	1	2	3	4	5
	active video			equalization pulses		serration pulses		equalization pulses		
Line number (2nd field)	309	310	311	312	313	314	315	316	317	318
	active video		equalization pulses			serration pulses		equalization pulses		
LCR (VOFF = 007H; HOFF = 354H; FOFF = 1; FISET = 0)	24						2	3	4	5

9-bit video input processor

SAA7113H

Table 11 Relationship of LCR to line numbers in 625 lines/50 Hz systems (part 2)

VERTICAL LINE OFFSET VOFF8 TO VOFF0 = 007H; HORIZONTAL PIXEL OFFSET HOFF10 TO HOFF0 = 354H, FOFF = 1, FISET = 0																				
Line number (1st field)	6	7	8	9	10	11	12	13	14	15	16	17	18	19	20	21	22	23	24	25
	nominal VBI-lines F1																		active video	
Line number (2nd field)	319	320	321	322	323	324	325	326	327	328	329	330	331	332	333	334	335	336	337	338
	nominal VBI-lines F2																		active video	
LCR (VOFF = 007H; HOFF = 354H; FOFF = 1; FISET = 0)	6	7	8	9	10	11	12	13	14	15	16	17	18	19	20	21	22	23	24	

Table 12 Location of related programming registers

NAME	SUBADDRESS, BITS
VOFF8 to VOFF0	5B, D4 and 5A, D7 to D0
HOFF10 to HOFF0	5B, D2 to D0 and 59, D7 to D0
FOFF	5B, D7
FISET	40, D7

9-bit video input processor

SAA7113H

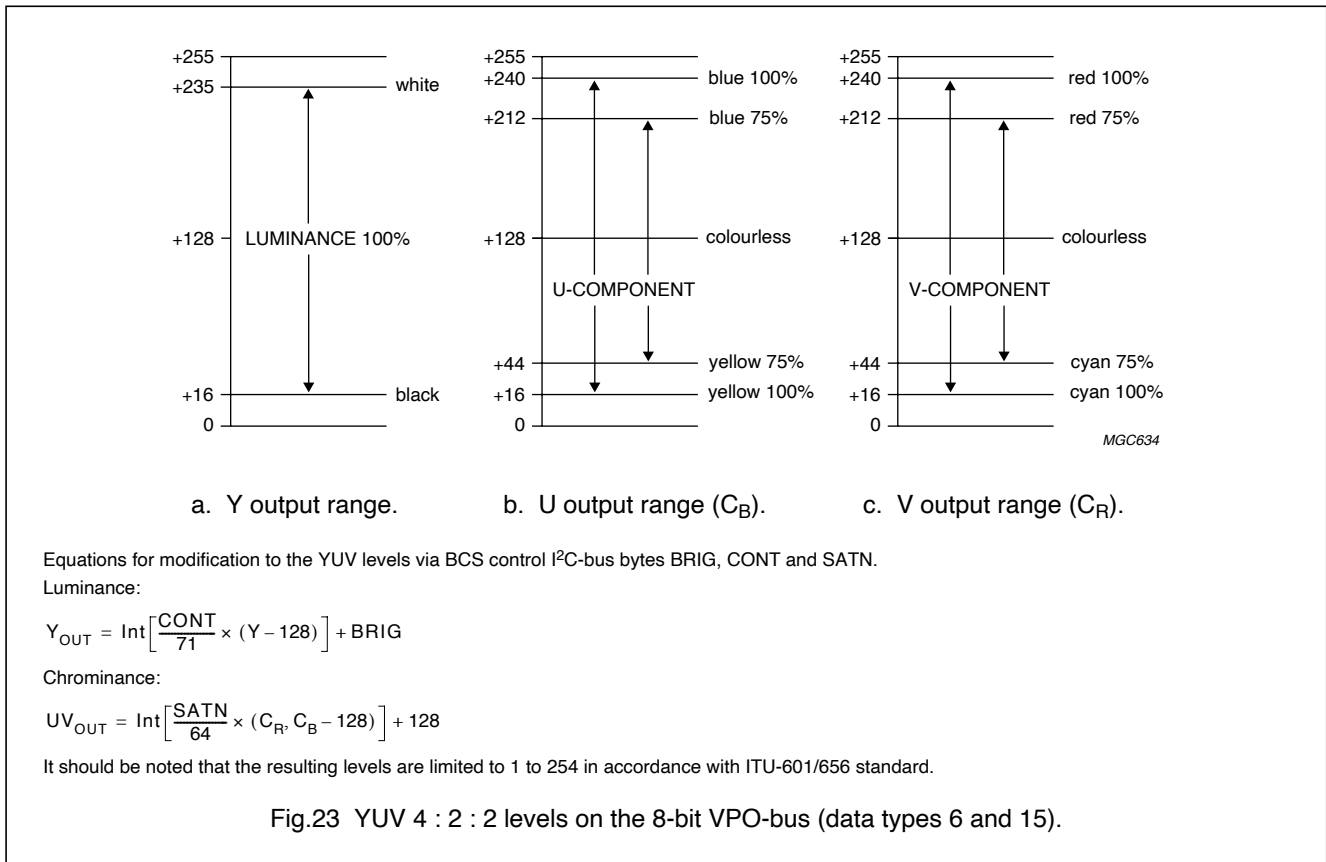

Table 13 YUV data format on the 8-bit VPO-bus (data types 6 and 15)

BLANKING PERIOD			TIMING REFERENCE CODE				720 PIXELS YUV 4 : 2 : 2 DATA										TIMING REFERENCE CODE				BLANKING PERIOD		
...	80	10	FF	00	00	SAV	C _B 0	Y0	C _R 0	Y1	C _B 2	Y2	...	C _R 718	Y719	FF	00	00	EAV	80	10	...	

Table 14 Explanation to Table 13

NAME	EXPLANATION
SAV	start of active video range; see Tables 5 to 7
C _{Bn}	U (B – Y) colour difference component, pixel number n = 0, 2, 4 to 718
Y _n	Y (luminance) component, pixel number n = 0, 1, 2, 3 to 719
C _{Rn}	V (R – Y) colour difference component, pixel number n = 0, 2, 4 to 718
EAV	end of active video range; see Tables 5 to 7

9-bit video input processor

SAA7113H

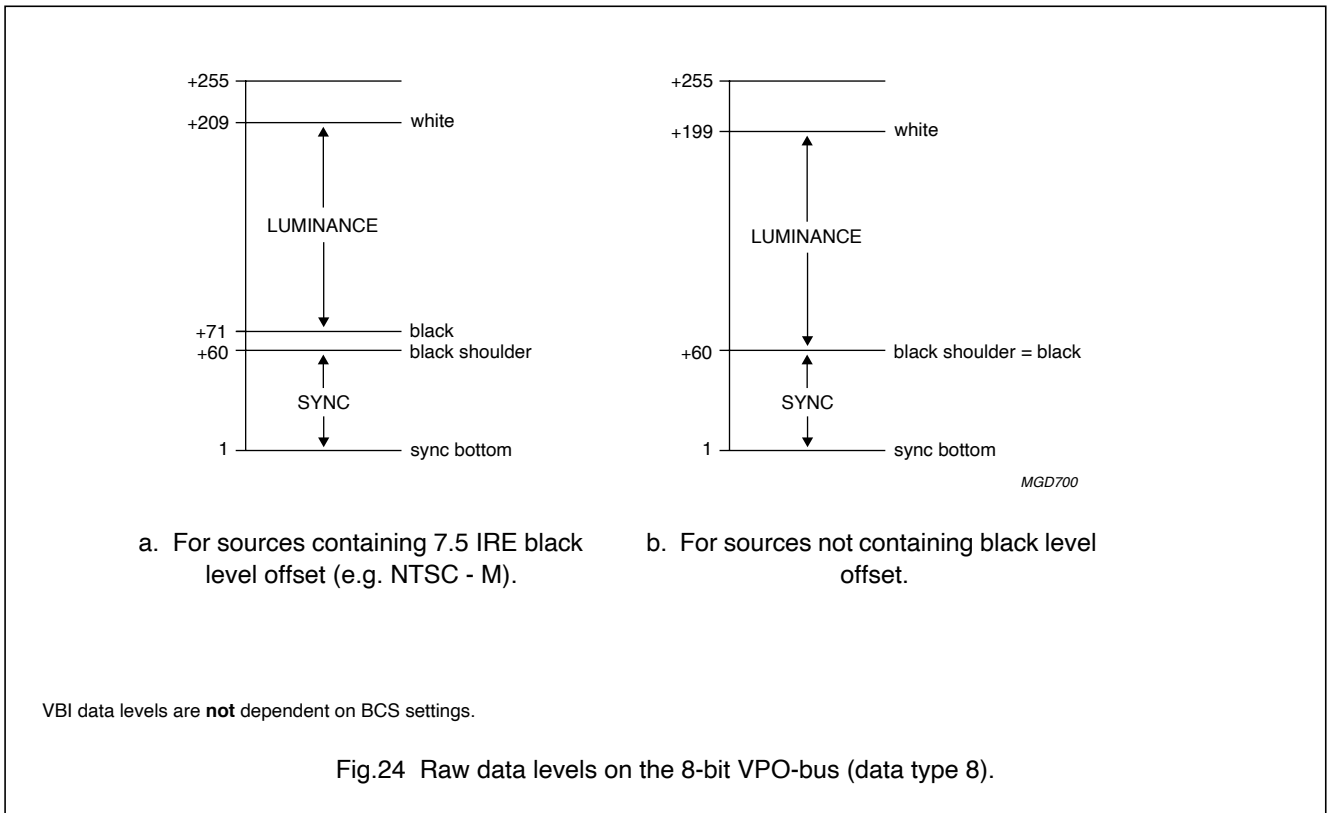

Table 15 Raw data format on the 8-bit VPO-bus (data type 8)

BLANKING PERIOD			TIMING REFERENCE CODE				OVERSAMPLED CVBS SAMPLES										TIMING REFERENCE CODE				BLANKING PERIOD		
...	80	10	FF	00	00	SAV	Y0	Y1	Y2	Y3	Y4	Y5	...	Yn - 1	Yn	FF	00	00	EAV	80	10	...	

Table 16 Explanation to Table 15

NAME	EXPLANATION
SAV	start of raw sample range; see Tables 5 to 7
Yi	oversampled raw sample stream (CVBS signal), n = 0, 1, 2, 3 to n; n is programmable via HSB and HSS; see Sections 15.2.7 and 15.2.8
EAV	end of raw sample range; see Tables 5 to 7

9-bit video input processor

SAA7113H

Table 17 Sliced data format on the 8-bit VPO-bus (data types 0 to 5 and 8 to 14)

BLANKING PERIOD			TIMING REFERENCE CODE				INTERNAL HEADER				SLICED DATA				TIMING REFERENCE CODE				BLANKING PERIOD			
...	80	10	FF	00	00	SAV	SDID	DC	IDI1	IDI2	DLN1	DHN1	...	DLNn	DHNn	FF	00	00	EAV	80	10	...

Table 18 Explanation to Table 17

NAME	EXPLANATION
SAV	start of active data; see Tables 5 to 7
SDID	sliced data identification: NEP ⁽¹⁾ , EP ⁽²⁾ , SDID5 to SDID0, freely programmable via I ² C-bus subaddress 5EH, D5 to D0, e. g. to be used as source identifier
DC	Dword count: NEP ⁽¹⁾ , EP ⁽²⁾ , DC5 to DC0; DC is inserted for software compatibility reasons to SAA7112, but does not represent any relevant information for SAA7113H applications. DC describes the number of succeeding 32-bit words: $DC = \frac{1}{4}(C + n)$, where C = 2 (the two data identification bytes IDI1 and IDI2) and n = number of decoded bytes according to the chosen text standard. As the sliced data are transmitted nibble wise, the maximum number of bytes transmitted (NBT) starting at IDI1 results to: $NBS = (DC \times 8) - 2$ DC can vary between 1 and 11, depending on the selected data type. Note that the number of bytes actually transmitted can be less than NBT for two reasons: 1. result of DC would result to a non-integer value (DC is always rounded up) 2. standard not recognized (wrong standard or poor input signal)
IDI1	internal data identification 1: OP ⁽³⁾ , FID (field 1 = 0, field 2 = 1), LineNumber8 to LineNumber3
IDI2	internal data identification 2: OP ⁽³⁾ , LineNumber2 to LineNumber0, DataType3 to DataType0; see Table 4
DLNn	sliced data LOW nibble, format: NEP ⁽¹⁾ , EP ⁽²⁾ , D3 to D0, 1, 1
DLHn	sliced data HIGH nibble, format: NEP ⁽¹⁾ , EP ⁽²⁾ , D7 to D4, 1, 1
EAV	end of active data; see Tables 5 to 7

Notes

1. Inverted EP (bit 7); for EP see note 2.
2. Even parity (bit 6) of bits 5 to 0.
3. Odd parity (bit 7) of bits 6 to 0.

9-bit video input processor

SAA7113H

8.11 RTCO output

The real-time control and status output signal contains serial information about the actual system clock (increment of the HPLL), subcarrier frequency, increment and phase (via reset) of the FSC-PLL and PAL sequence bit. The signal can be used for various applications in external circuits, e.g. in a digital encoder to achieve clean encoding. The SAA7113H supports RTC level 3.1 (see external document “RTC Functional Description”, available on request).

8.12 RTS0, RTS1 terminals

These two pins are multi functional inputs/output controlled by I²C-bus bits RTSE03 to RTSE00 and RTSE13 to RTSE10, located in subaddress 12H; see Tables 49 and 50.

The RTS0 terminal can be strapped to ground via a 3.3 kΩ resistor to change the I²C-bus slave address from default 4AH/4BH to 48H/49H (the strapping information is read only during the reset sequence).

The RTS1 terminal can be configured as Data Output to 3-state (DOT) input by RTSE13 to RTSE10 = 0000 to control the VPO port (bits 7 to 0) via hardware according to Table 19.

Table 19 Digital output control via RTS1 (enabled by bits RTSE13 to RTSE10 = 0)

OEYC	DOT (RTS1)	VPO7 TO VPO0
0	0	Z
1	0	active
0	1	Z
1	1	Z

9 BOUNDARY SCAN TEST

The SAA7113H has built in logic and 5 dedicated pins to support boundary scan testing which allows board testing without special hardware (nails). The SAA7113H follows the “IEEE Std. 1149.1 - Standard Test Access Port and Boundary-Scan Architecture” set by the Joint Test Action Group (JTAG) chaired by Philips.

The 5 special pins are Test Mode Select (TMS), Test Clock (TCK), Test Reset (TRST), Test Data Input (TDI) and Test Data Output (TDO).

The BST functions BYPASS, EXTEST, INTEST, SAMPLE, CLAMP and IDCODE are all supported (see Table 20). Details about the JTAG BST-TEST can be found in the specification “IEEE Std. 1149.1”. A file containing the detailed Boundary Scan Description Language (BSDL) description of the SAA7113H is available on request.

Table 20 BST instructions supported by the SAA7113H

INSTRUCTION	DESCRIPTION
BYPASS	This mandatory instruction provides a minimum length serial path (1 bit) between TDI and TDO when no test operation of the component is required.
EXTEST	This mandatory instruction allows testing of off-chip circuitry and board level interconnections.
SAMPLE	This mandatory instruction can be used to take a sample of the inputs during normal operation of the component. It can also be used to preload data values into the latched outputs of the boundary scan register.
CLAMP	This optional instruction is useful for testing when not all ICs have BST. This instruction addresses the bypass register while the boundary scan register is in external test mode.
IDCODE	This optional instruction will provide information on the components manufacturer, part number and version number.
INTEST	This optional instruction allows testing of the internal logic (no support for customers available).
USER1	This private instruction allows testing by the manufacturer (no support for customers available).

9-bit video input processor

SAA7113H

9.1 Initialization of boundary scan circuit

The TAP (Test Access Port) controller of an IC should be in the reset state (TEST_LOGIC_RESET) when the IC is in functional mode. This reset state also forces the instruction register into a functional instruction such as IDCODE or BYPASS.

To solve the power-up reset, the standard specifies that the TAP controller will be forced asynchronously to the TEST_LOGIC_RESET state by setting the TRST pin LOW.

9.2 Device identification codes

A device identification register is specified in "IEEE Std. 1149.1b-1994". It is a 32-bit register which contains fields for the specification of the IC manufacturer, the IC part number and the IC version number. Its biggest advantage is the possibility to check for the correct ICs mounted after production and determination of the version number of ICs during field service.

When the IDCODE instruction is loaded into the BST instruction register, the identification register will be connected between TDI and TDO of the IC.

The identification register will load a component specific code during the CAPTURE_DATA_REGISTER state of the TAP controller and this code can subsequently be shifted out. At board level this code can be used to verify component manufacturer, type and version number.

The device identification register contains 32 bits, numbered 31 to 0, where bit 31 is the most significant bit (nearest to TDI) and bit 0 is the least significant bit (nearest to TDO); see Fig.25.

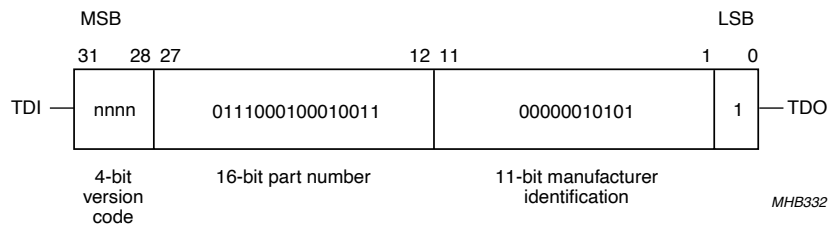

Fig.25 32 bits of identification code.

9-bit video input processor

SAA7113H

10 LIMITING VALUES

In accordance with the Absolute Maximum Rating System (IEC 134); all ground pins connected together and all supply pins connected together.

SYMBOL	PARAMETER	CONDITIONS	MIN.	MAX.	UNIT
V_{DDD}	digital supply voltage		-0.5	+4.6	V
V_{DDA}	analog supply voltage		-0.5	+4.6	V
V_{iA}	input voltage at analog inputs		-0.5	$V_{DDA} + 0.5$ (4.6 max)	V
V_{oA}	output voltage at analog output		-0.5	$V_{DDA} + 0.5$	V
V_{iD}	input voltage at digital inputs and outputs	outputs in 3-state	-0.5	+5.5	V
V_{oD}	output voltage at digital outputs	outputs active	-0.5	$V_{DDD} + 0.5$	V
ΔV_{SS}	voltage difference between $V_{SSA(all)}$ and $V_{SS(all)}$		-	100	mV
T_{stg}	storage temperature		-65	+150	°C
T_{amb}	operating ambient temperature		0	70	°C
$T_{amb(bias)}$	operating ambient temperature under bias		-10	+80	°C
V_{esd}	electrostatic discharge all pins	note 1	-2000	+2000	V

Note

- Human body model: equivalent to discharging a 100 pF capacitor through a 1.5 k Ω resistor.

11 THERMAL CHARACTERISTICS

SYMBOL	PARAMETER	CONDITIONS	VALUE	UNIT
$R_{th(j-a)}$	thermal resistance from junction to ambient	in free air	64	K/W

9-bit video input processor

SAA7113H

12 CHARACTERISTICS

$V_{DDDD} = 3.0$ to 3.6 V; $V_{DDA} = 3.1$ to 3.5 V; $T_{amb} = 25$ °C; unless otherwise specified.

SYMBOL	PARAMETER	CONDITIONS	MIN.	TYP.	MAX.	UNIT
Supplies						
V_{DDDD}	digital supply voltage		3.0	3.3	3.6	V
I_{DDDD}	digital supply current		–	32	35	mA
P_D	digital power		–	0.10	–	W
V_{DDA}	analog supply voltage	$V_{DDA} \leq V_{DDDD} + 200$ mV	3.1	3.3	3.5	V
I_{DDA}	analog supply current	AOSL1 to AOSL0 = 0	–	90	–	mA
P_A	analog power		–	0.30	–	W
P_{A+D}	analog and digital power		–	0.40	–	W
$P_{A+D(pd)}$	analog and digital power in power-down mode	CE connected to ground	–	0.07	–	W
Analog part						
I_{clamp}	clamping current	$V_I = 0.9$ V DC	–	± 8	–	μ A
$V_{i(p-p)}$	input voltage (peak-to-peak value)	for normal video levels 1 V (p-p), termination $18/56 \Omega$ and AC coupling required; coupling capacitor = 47 nF	0.5	0.7	1.4	V
$ Z_i $	input impedance	clamping current off	200	–	–	k Ω
C_i	input capacitance		–	–	10	pF
α_{cs}	channel crosstalk	$f_i = 5$ MHz	–	–	–50	dB
9-bit analog-to-digital converters						
B	bandwidth	at –3 dB	–	7	–	MHz
ϕ_{diff}	differential phase (amplifier plus anti-alias filter bypassed)		–	2	–	deg
G_{diff}	differential gain (amplifier plus anti-alias filter bypassed)		–	2	–	%
$f_{clk(ADC)}$	ADC clock frequency		12.8	–	14.3	MHz
DLE	DC differential linearity error		–	0.7	–	LSB
ILE	DC integral linearity error		–	1	–	LSB

9-bit video input processor

SAA7113H

SYMBOL	PARAMETER	CONDITIONS	MIN.	TYP.	MAX.	UNIT
Digital inputs						
$V_{IL(SCL,SDA)}$	LOW-level input voltage pins SDA and SCL		-0.5	-	+0.3V _{DD}	V
$V_{IH(SCL,SDA)}$	HIGH-level input voltage pins SDA and SCL		0.7V _{DD}	-	V _{DD} + 0.5	V
$V_{IL(xtal)}$	LOW-level CMOS input voltage pin XTALI		-0.3	-	+0.8	V
$V_{IH(xtal)}$	HIGH-level CMOS input voltage pin XTALI		2.0	-	V _{DD} + 0.3	V
$V_{IL(n)}$	LOW-level input voltage all other inputs		-0.3	-	+0.8	V
$V_{IH(n)}$	HIGH-level input voltage all other inputs		2.0	-	5.5	V
I_{LI}	input leakage current		-	-	10	μA
C_i	input capacitance	outputs at 3-state	-	-	8	pF
$C_{i(n)}$	input capacitance all other inputs		-	-	5	pF
Digital outputs						
$V_{OL(SCL,SDA)}$	LOW-level output voltage pins SDA and SCL	SDA/SCL at 3 mA (6 mA) sink current	-	-	0.4 (0.6)	V
V_{OL}	LOW-level output voltage	V _{DD} = max; I _{OL} = 2 mA	0	-	0.4	V
V_{OH}	HIGH-level output voltage	V _{DD} = min; I _{OH} = -2 mA	2.4	-	V _{DD} + 0.5	V
$V_{OL(clk)}$	LOW-level output voltage for LLC clock		-0.5	-	+0.6	V
$V_{OH(clk)}$	HIGH-level output voltage for LLC clock		2.4	-	V _{DD} + 0.5	V
RTS1 (DOT) input timing						
$t_{SU;DAT}$	input data set-up time		13	-	-	ns
$t_{HD;DAT}$	input data hold time		3	-	-	ns
Data and control output timing; note 1						
C_L	output load capacitance		15	-	40	pF
$t_{OHD;DAT}$	output hold time	C _L = 15 pF	4	-	-	ns
t_{PD}	propagation delay	C _L = 25 pF	-	-	22	ns
t_{PDZ}	propagation delay to 3-state		-	-	22	ns

9-bit video input processor

SAA7113H

SYMBOL	PARAMETER	CONDITIONS	MIN.	TYP.	MAX.	UNIT
Clock output timing (LLC); note 2						
$C_{L(LLC)}$	output load capacitance		15	–	40	pF
T_{cy}	cycle time	LLC	35	–	39	ns
δ_{LLC}	duty factors for t_{LLCH}/t_{LLC}	$C_L = 25$ pF	40	–	60	%
t_r	rise time LLC		–	–	5	ns
t_f	fall time LLC		–	–	5	ns
Clock input timing (XTALI)						
δ_{XTALI}	duty factor for t_{XTALIH}/t_{XTALI}	nominal frequency	40	–	60	%
Horizontal PLL						
f_{Hn}	nominal line frequency	50 Hz field	–	15625	–	Hz
		60 Hz field	–	15734	–	Hz
$\Delta f_H/f_{Hn}$	permissible static deviation		–	–	5.7	%
Subcarrier PLL						
f_{SCn}	nominal subcarrier frequency	PAL BGHIN	–	4433619	–	Hz
		NTSC M; NTSC-Japan	–	3579545	–	Hz
		PAL M	–	3575612	–	Hz
		combination-PAL N	–	3582056	–	Hz
Δf_{SC}	lock-in range		± 400	–	–	Hz
Crystal oscillator						
f_n	nominal frequency	3rd harmonic; note 3	–	24.576	–	MHz
$\Delta f/f_n$	permissible nominal frequency deviation		–	–	± 50	10^{-6}
$\Delta T/f_{n(T)}$	permissible nominal frequency deviation with temperature		–	–	± 20	10^{-6}
CRYSTAL SPECIFICATION (X1)						
$T_{amb(X1)}$	operating ambient temperature		0	–	70	$^{\circ}\text{C}$
C_L	load capacitance		8	–	–	pF
R_s	series resonance resistor		–	40	80	Ω
C_1	motional capacitance		–	$1.5 \pm 20\%$	–	fF
C_0	parallel capacitance		–	$3.5 \pm 20\%$	–	pF

Notes

- The levels must be measured with load circuits; 1.2 k Ω at 3 V (TTL load); $C_L = 50$ pF.
- The effects of rise and fall times are included in the calculation of $t_{OHD;DAT}$, t_{PD} and t_{PDZ} . Timings and levels refer to drawings and conditions illustrated in Fig.26.
- Order number: Philips 4322 143 05291.

9-bit video input processor

SAA7113H

Table 21 Processing delay

FUNCTION	TYPICAL ANALOG DELAY AI22 → ADCIN (AOUT) (ns)	DIGITAL DELAY ADCIN → VPO (LLC CLOCKS); YDEL2 TO YDEL0 = 0
Without amplifier or anti-alias filter	15	157
With amplifier, without anti-alias filter	25	
With amplifier and anti-alias filter	75	

9-bit video input processor

SAA7113H

13 TIMING DIAGRAMS

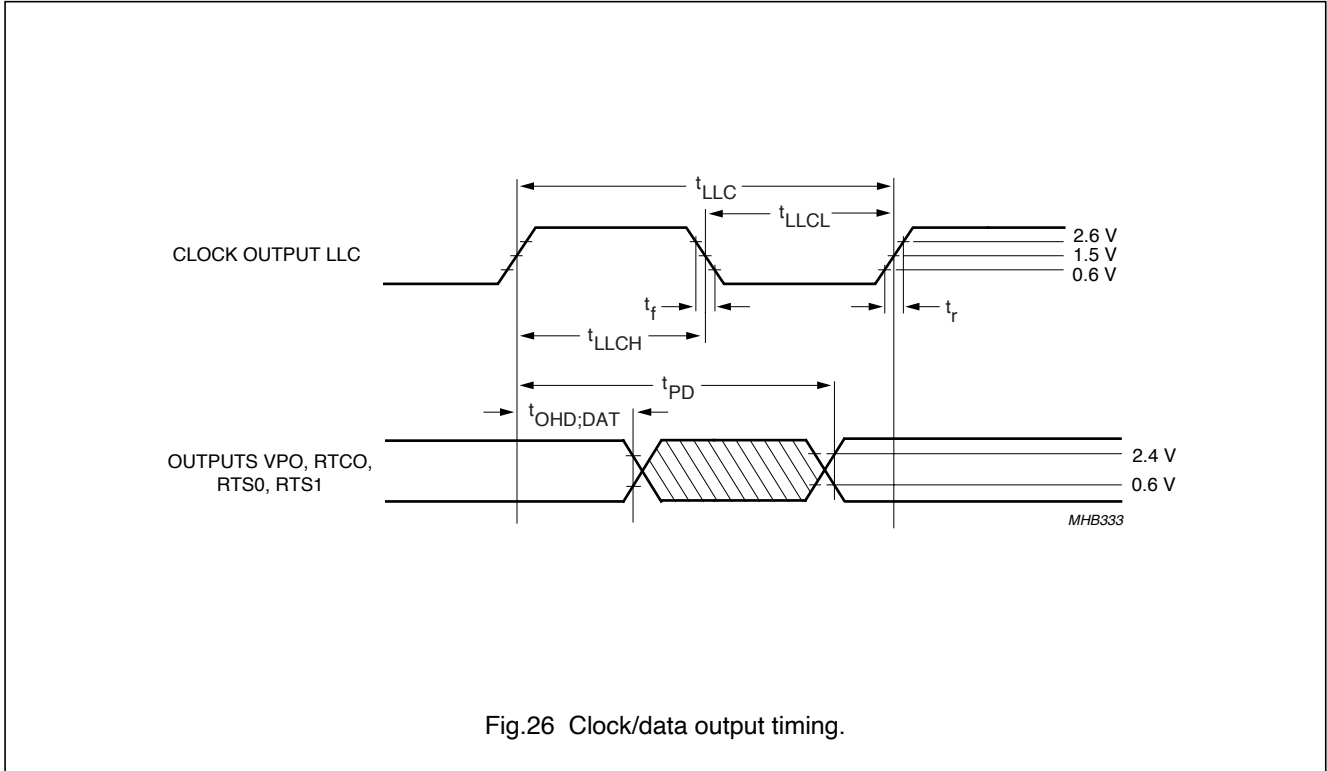

Fig.26 Clock/data output timing.

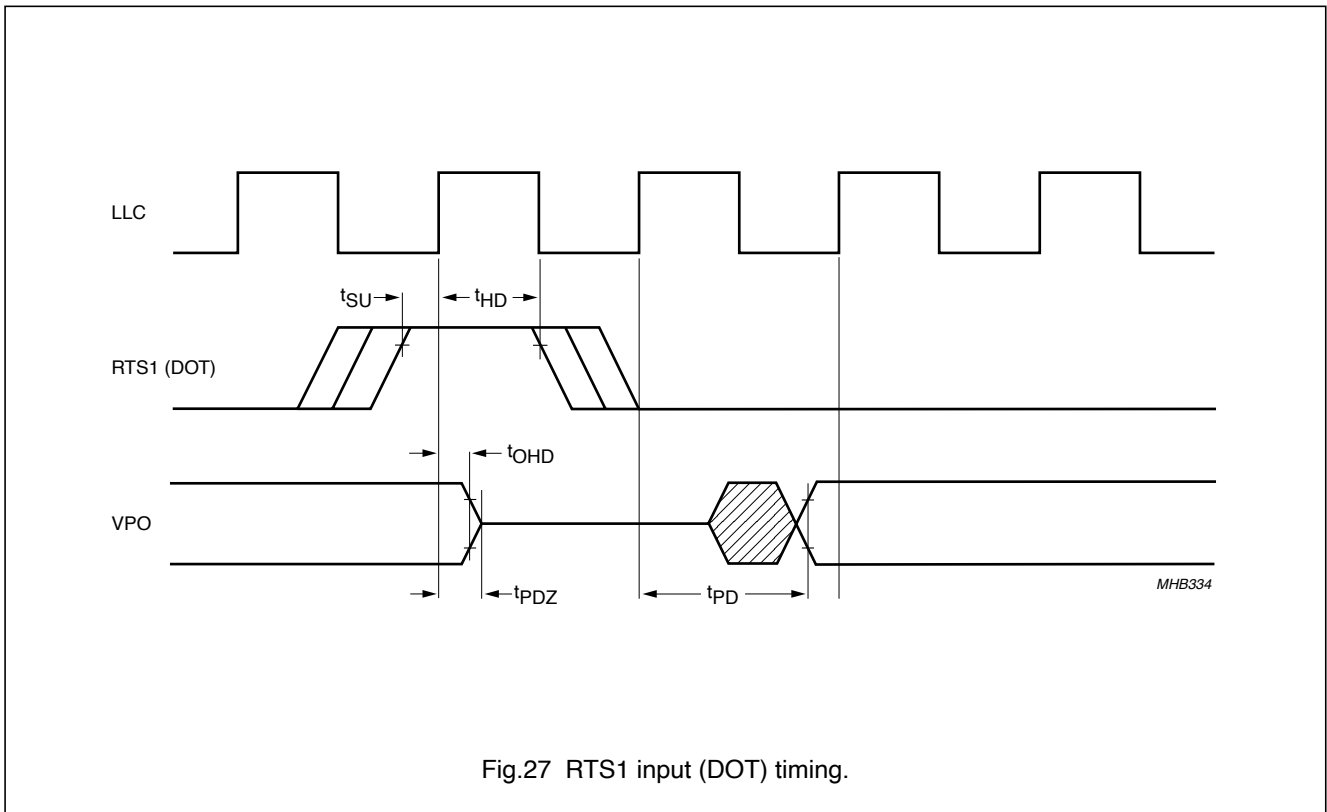
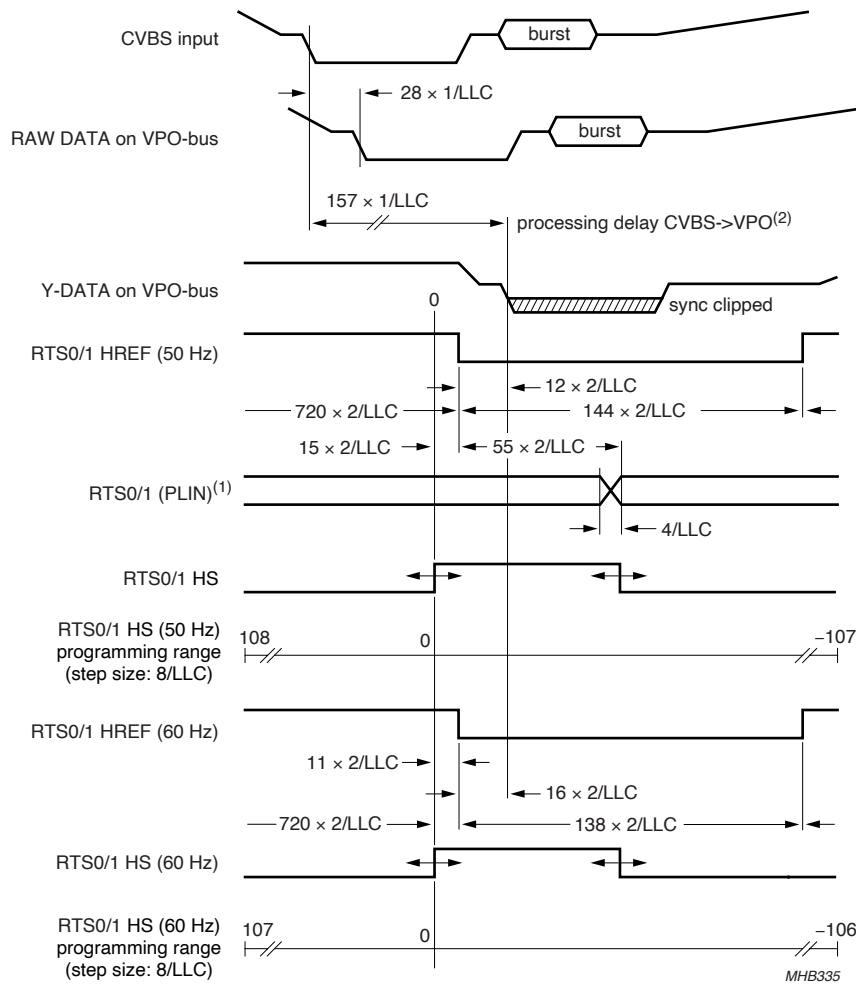

Fig.27 RTS1 input (DOT) timing.

9-bit video input processor

SAA7113H



(1) PLIN is switched to outputs RTS0 and/or RTS1 via I²C-bus bits RTSE13 to RTSE10 and/or RTSE03 to RTSE00.
 (2) See Table 21.

Fig.28 Horizontal timing diagram.

9-bit video input processor

SAA7113H

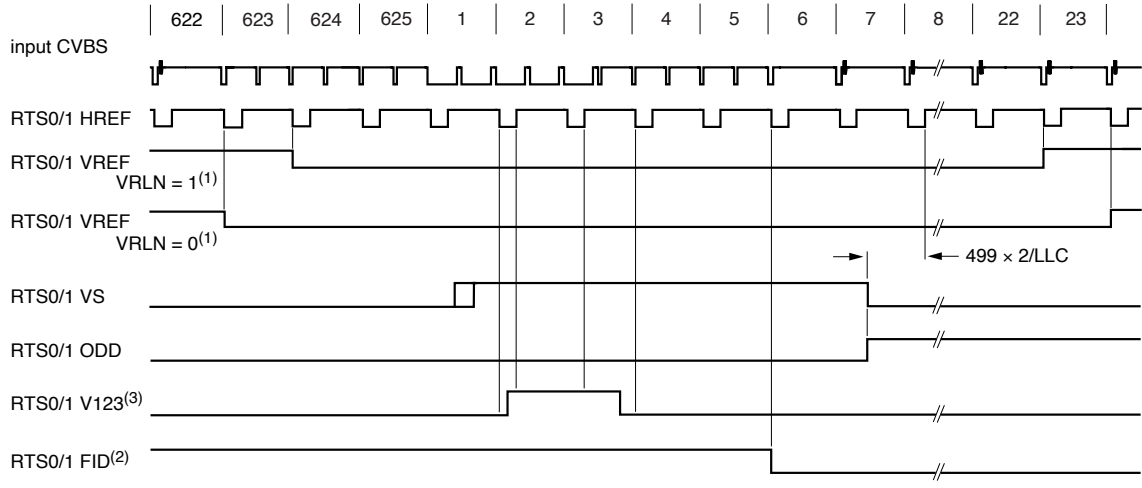

(a) 1st field

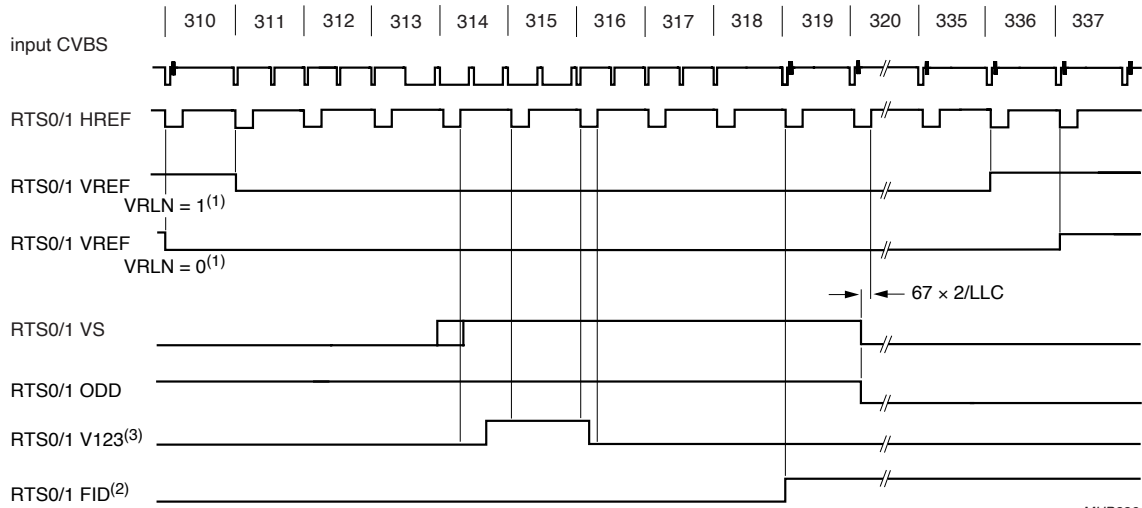

(b) 2nd field

MHB336

HREF: selectable on RTS0 and/or RTS1 via I²C-bus bits RTSE03 to RTSE00 and/or RTSE13 to RTSE10 = 7H.

ODD: selectable on RTS0 and/or RTS1 via I²C-bus bits RTSE03 to RTSE00 and/or RTSE13 to RTSE10 = AH.

VS: selectable on RTS0 and/or RTS1 via I²C-bus bits RTSE03 to RTSE00 and/or RTSE13 to RTSE10 = BH.

V123: selectable on RTS0 and/or RTS1 via I²C-bus bits RTSE03 to RTSE00 and/or RTSE13 to RTSE10 = CH.

VREF: selectable on RTS0 and/or RTS1 via I²C-bus bits RTSE03 to RTSE00 and/or RTSE13 to RTSE10 = EH.

FID: selectable on RTS0 and/or RTS1 via I²C-bus bits RTSE03 to RTSE00 and/or RTSE13 to RTSE10 = FH.

(1) VREF range short or long can be programmed via I²C-bus bit VRLN.

The luminance peaking and the chrominance trap are bypassed during VREF = 0 if I²C-bus bit VBLB is set to logic 1.

The chrominance delay line (chrominance-comb filter for NTSC, phase error correcting for PAL) is disabled during VREF = 0.

(2) FID changing line number and polarity programmable via VSTA8 to VSTA0 and FIDP, see Table 52.

(3) The inactive going edge of the V123-signal indicates whether the field is odd or even. If HREF is active during the falling edge of V123, the field is **odd**. If HREF is inactive during the falling edge of V123, the field is **even**. The specific position of the slope is dependent on the internal processing delay and may change a few clock cycles from version to version.

Fig.29 Vertical timing diagram for 50 Hz [nominal input signal, VNL in normal mode (VNOI = 00), HPLL in VCR or fast mode (HTC = 01 or 11)].

9-bit video input processor

SAA7113H

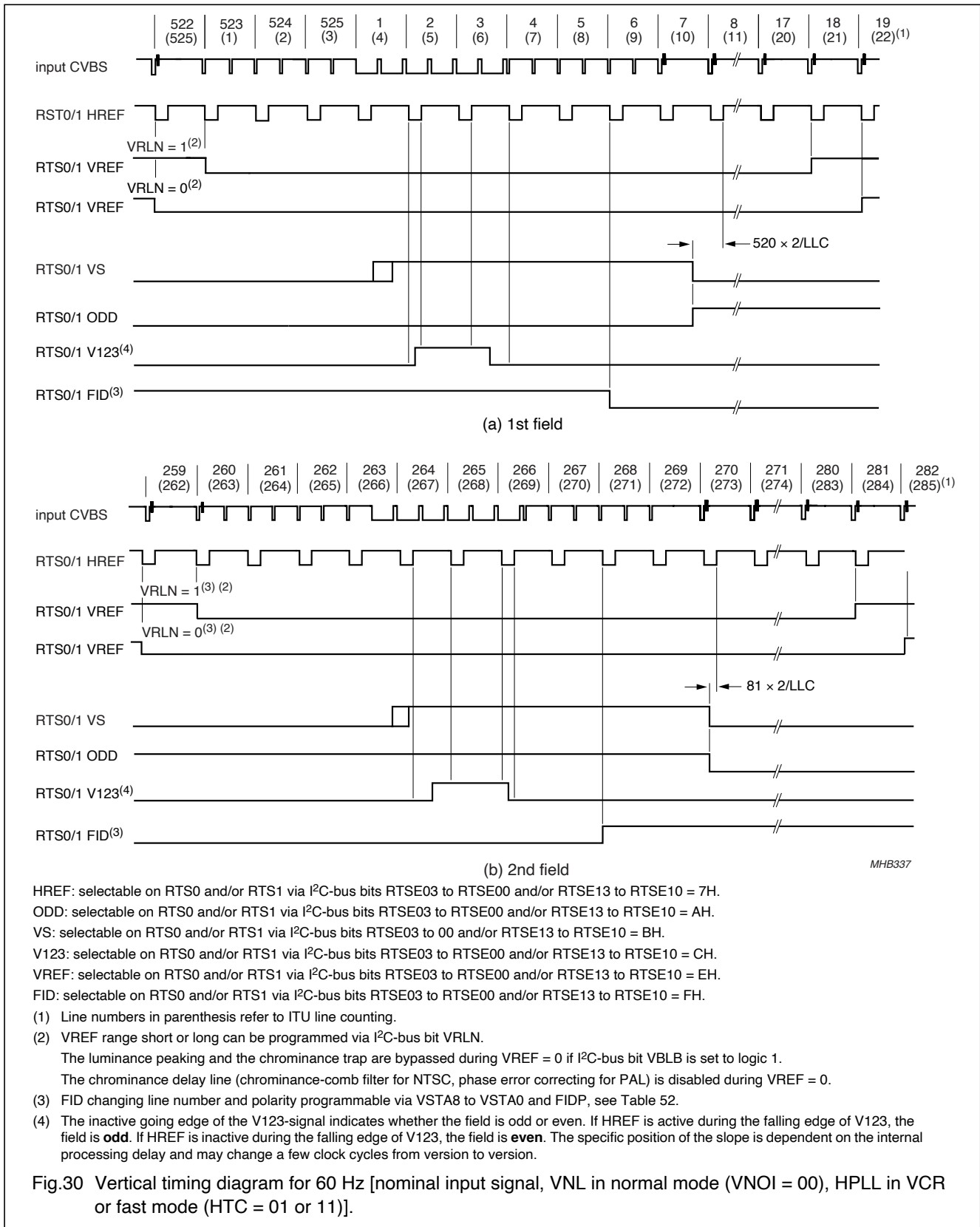

9-bit video input processor

SAA7113H

14 APPLICATION INFORMATION

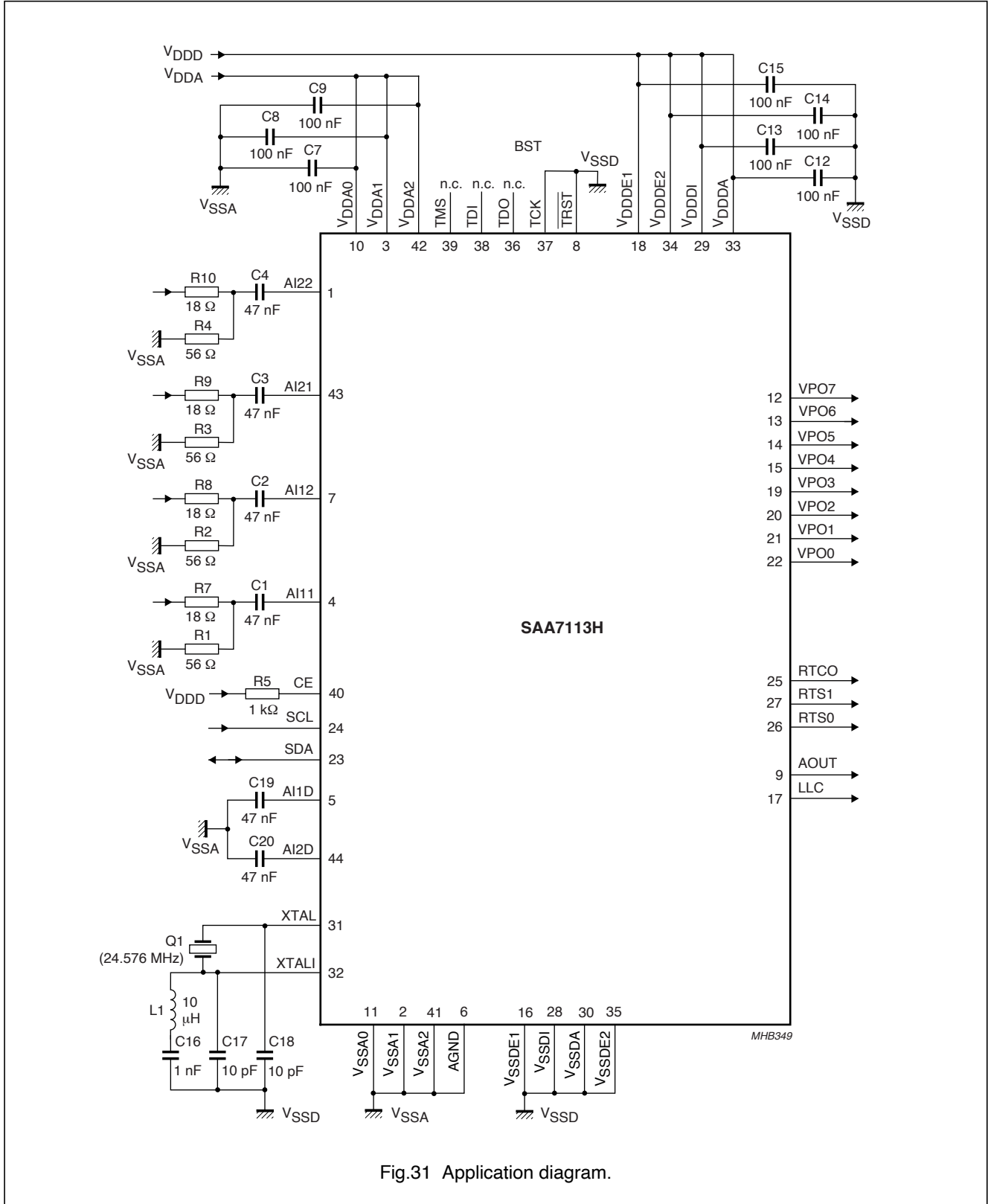
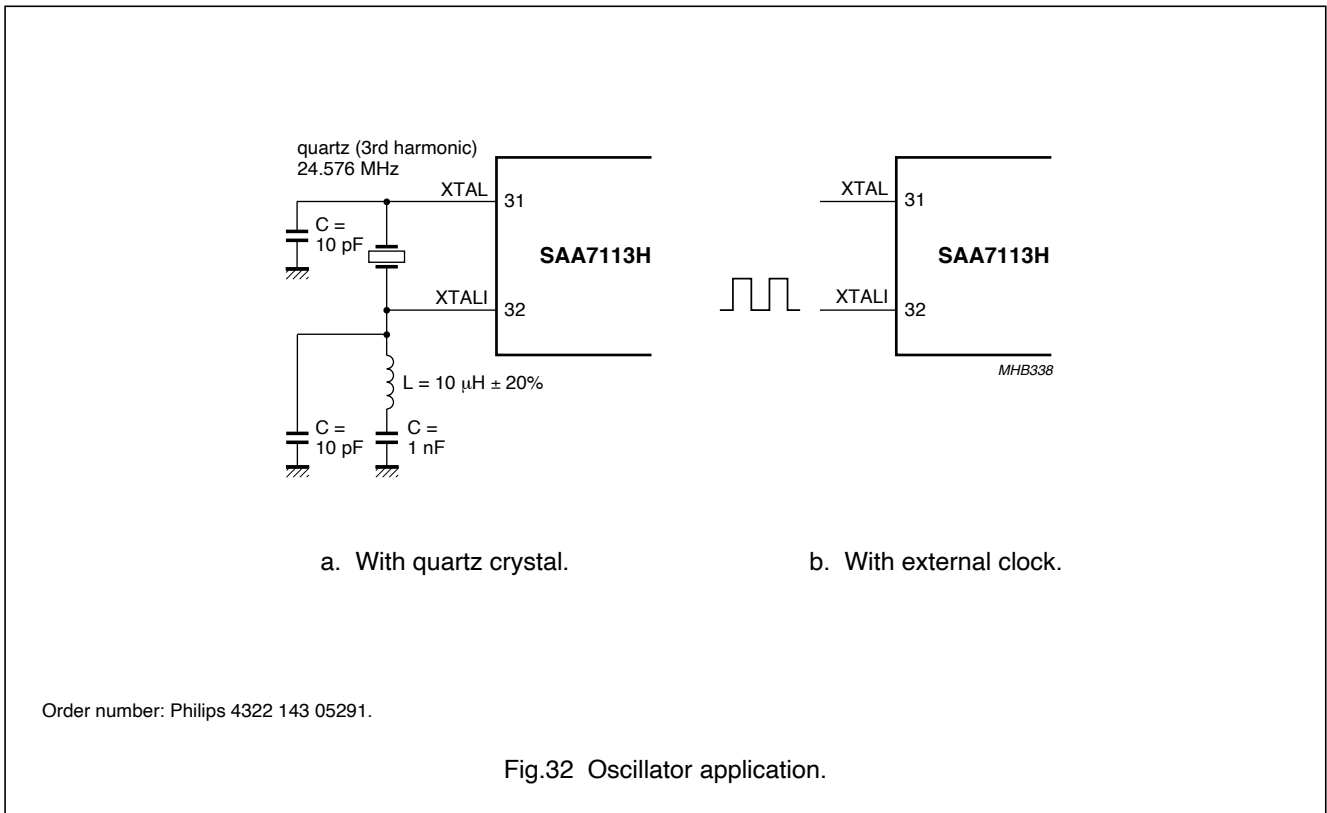

Fig.31 Application diagram.

9-bit video input processor

SAA7113H



15 I²C-BUS DESCRIPTION

15.1 I²C-bus format

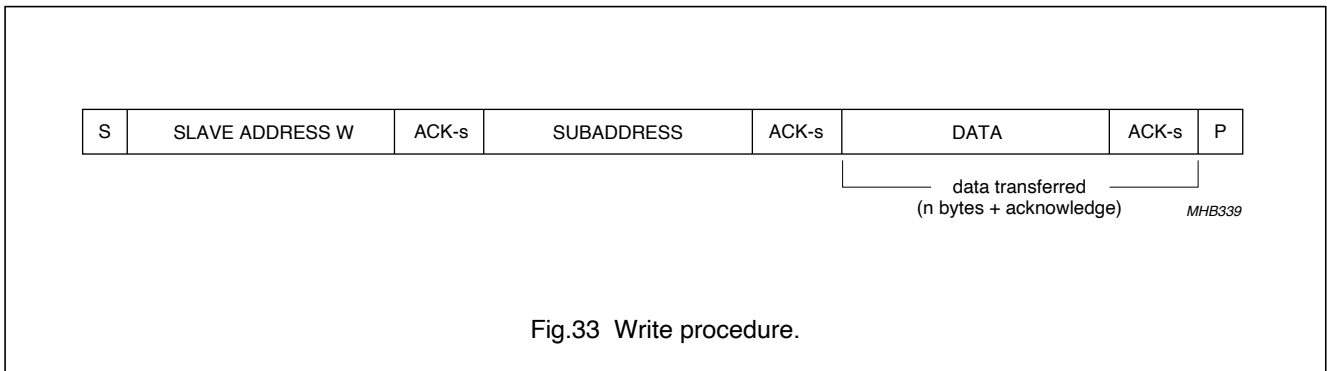

9-bit video input processor

SAA7113H

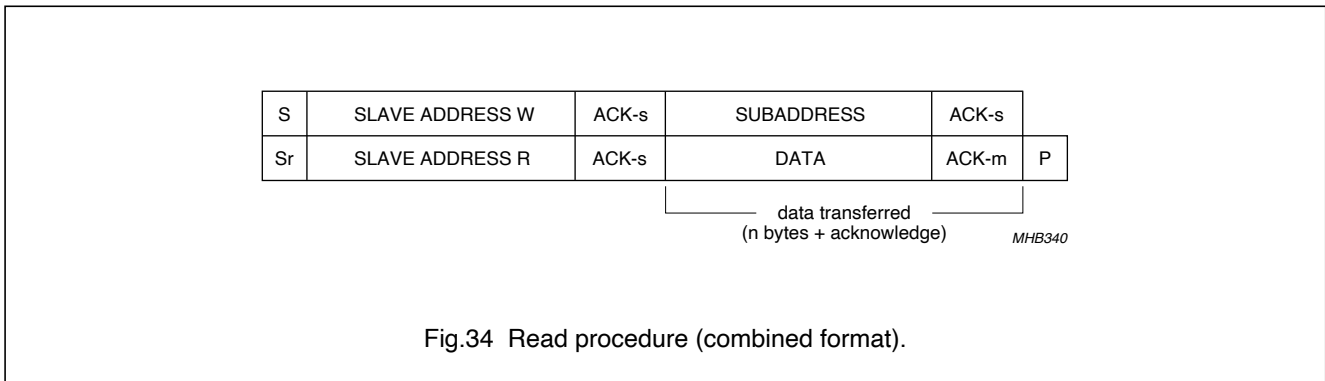

Fig.34 Read procedure (combined format).

Table 22 Description of I²C-bus format; note 1

CODE	DESCRIPTION	
S	START condition	
Sr	repeated START condition	
Slave address W	0100 1010 (= 4AH, default) or 0100 1000 (= 48H, if pin RTS0 strapped to ground via a 3.3 kΩ resistor)	
Slave address R	0100 1011 (= 4BH, default) or 0100 1001 (= 49H, if pin RTS0 strapped to ground via a 3.3 kΩ resistor)	
ACK-s	acknowledge generated by the slave	
ACK-m	acknowledge generated by the master	
Subaddress	subaddress byte; see Table 24	
Data	data byte; see Table 24; note 2	
P	STOP condition	
X = LSB slave address	read/write control bit; X = 0, order to write (the circuit is slave receiver); X = 1, order to read (the circuit is slave transmitter)	
Subaddresses	00H chip version	read only
	01H to 05H front-end part	read and write
	06H to 13H decoder part	read and write
	14H reserved	–
	15H to 17H decoder part	read and write
	18H to 1EH reserved	–
	1FH video decoder status byte	read only
	20H to 3FH reserved	–
	40H to 60H general purpose data slicer	read and write
	60H to 62H general purpose data slicer status	read only
63H to FFH reserved	–	

Notes

1. The SAA7113H supports the 'fast mode' I²C-bus specification extension (data rate up to 400 kbits/s).
2. If more than one byte DATA is transmitted the subaddress pointer is automatically incremented.

9-bit video input processor

SAA7113H

Table 23 Slave address

READ	WRITE	DESCRIPTION
4BH	4AH	default
49H	48H	RTS0 strapped to ground

9-bit video input processor

SAA713H

Table 24 I²C-bus receiver/transmitter overview

REGISTER FUNCTION	SUB-ADDR. (HEX)	D7	D6	D5	D4	D3	D2	D1	D0
Chip version (read only)	00	ID07	ID06	ID05	ID04	–	–	–	–
Increment delay	01	(1)	(1)	(1)	(1)	IDEL3	IDEL2	IDEL1	IDEL0
Analog input control 1	02	FUSE1	FUSE0	GUDL1	GUDL0	MODE3	MODE2	MODE1	MODE0
Analog input control 2	03	(1)	HLNRS	VBSL	WPOFF	HOLDG	GAFIX	GAI28	GAI18
Analog input control 3	04	GAI17	GAI16	GAI15	GAI14	GAI13	GAI12	GAI11	GAI10
Analog input control 4	05	GAI27	GAI26	GAI25	GAI24	GAI23	GAI22	GAI21	GAI20
Horizontal sync start	06	HSB7	HSB6	HSB5	HSB4	HSB3	HSB2	HSB1	HSB0
Horizontal sync stop	07	HSS7	HSS6	HSS5	HSS4	HSS3	HSS2	HSS1	HSS0
Sync control	08	AUFD	FSEL	FOET	HTC1	HTC0	HPLL	VNOI1	VNOI0
Luminance control	09	BYPS	PREF	BPSS1	BPSS0	VBLB	UPTCV	APER1	APER0
Luminance brightness	0A	BRIG7	BRIG6	BRIG5	BRIG4	BRIG3	BRIG2	BRIG1	BRIG0
Luminance contrast	0B	CONT7	CONT6	CONT5	CONT4	CONT3	CONT2	CONT1	CONT0
Chroma saturation	0C	SATN7	SATN6	SATN5	SATN4	SATN3	SATN2	SATN1	SATN0
Chroma hue control	0D	HUEC7	HUEC6	HUEC5	HUEC4	HUEC3	HUEC2	HUEC1	HUEC0
Chroma control	0E	CDTO	CSTD2	CSTD1	CSTD0	DCCF	FCTC	CHBW1	CHBW0
Chroma gain control	0F	ACGC	CGAIN6	CGAIN5	CGAIN4	CGAIN3	CGAIN2	CGAIN1	CGAIN0
Format/delay control	10	OFTS1	OFTS0	HDEL1	HDEL0	VRLN	YDEL2	YDEL1	YDEL0
Output control 1	11	GPSW1	CM99	GPSW0	HLSEL	OEYC	OERT	VIPB	COLO
Output control 2	12	RTSE13	RTSE12	RTSE11	RTSE10	RTSE03	RTSE02	RTSE01	RTSE00
Output control 3	13	ADLSB	(1)	(1)	OLDSB	FIDP	(1)	AOSL1	AOSL0
Reserved	14	(1)	(1)	(1)	(1)	(1)	(1)	(1)	(1)
V_GATE1_START	15	VSTA7	VSTA6	VSTA5	VSTA4	VSTA3	VSTA2	VSTA1	VSTA0
V_GATE1_STOP	16	VSTO7	VSTO6	VSTO5	VSTO4	VSTO3	VSTO2	VSTO1	VSTO0
V_GATE1_MSB	17	(1)	(1)	(1)	(1)	(1)	(1)	VSTO8	VSTA8
Reserved	18 to 1E	(1)	(1)	(1)	(1)	(1)	(1)	(1)	(1)
Status byte (read only, OLDSB = 0)	1F	INTL	HLVLN	FIDT	GLIMT	GLIMB	WIPA	COPRO	RDCAP
Status byte (read only, OLDSB = 1)	1F	INTL	HLCK	FIDT	GLIMT	GLIMB	WIPA	SLTCA	CODE
Reserved	20 to 3F	(1)	(1)	(1)	(1)	(1)	(1)	(1)	(1)

9-bit video input processor

SAA713H

REGISTER FUNCTION	SUB-ADDR. (HEX)	D7	D6	D5	D4	D3	D2	D1	D0
AC1	40	FISET	HAM_N	FCE	HUNT_N	(1)	CLKSEL1	CLKSEL0	(1)
LCR2	41	LCR02_7	LCR02_6	LCR02_5	LCR02_4	LCR02_3	LCR02_2	LCR02_1	LCR02_0
LCR3 to LCR23	42 to 56	LCRN_7	LCRN_6	LCRN_5	LCRN_4	LCRN_3	LCRN_2	LCRN_1	LCRN_0
LCR24	57	LCR24_7	LCR24_6	LCR24_5	LCR24_4	LCR24_3	LCR24_2	LCR24_1	LCR24_0
FC	58	FC7	FC6	FC5	FC4	FC3	FC2	FC1	FC0
HOFF	59	HOFF7	HOFF6	HOFF5	HOFF4	HOFF3	HOFF2	HOFF1	HOFF0
VOFF	5A	VOFF7	VOFF6	VOFF5	VOFF4	VOFF3	VOFF2	VOFF1	VOFF0
HVOFF	5B	FOFF	(1)	(1)	VOFF8	(1)	HOFF10	HOFF9	HOFF8
For testability	5C	(1)	(1)	(1)	(1)	(1)	(1)	(1)	(1)
Reserved	5D	(1)	(1)	(1)	(1)	(1)	(1)	(1)	(1)
Sliced data identification code SDID	5E	(1)	(1)	SDID5	SDID4	SDID3	SDID2	SDID1	SDID0
Reserved	5F	(1)	(1)	(1)	(1)	(1)	(1)	(1)	(1)
DR (read only)	60	–	FC8V	FC7V	VPSV	PPV	CCV	–	–
LN1 (read only)	61	–	–	F21_N	LN8	LN7	LN6	LN5	LN4
LN2 (read only)	62	LN3	LN2	LN1	LN0	DT3	DT2	DT1	DT0
Reserved for future extensions	63 to FF	(1)	(1)	(1)	(1)	(1)	(1)	(1)	(1)

Note

- All unused control bits must be programmed with logic 0 to ensure compatibility to future enhancements.

9-bit video input processor

SAA7113H

15.2 I²C-bus detail

The I²C-bus receiver slave address is 48H/49H. Subaddresses 14H, 18H to 1EH, 20H to 3FH and 63H to FFH are reserved.

15.2.1 SUBADDRESS 00H (READ ONLY REGISTER)

Table 25 Chip version SA 00

FUNCTION	LOGIC LEVELS			
	ID07	ID06	ID05	ID04
Chip Version (CV)	CV3	CV2	CV1	CV0

15.2.3 SUBADDRESS 02H

Table 27 Analog control 1 SA 02

FUNCTION ⁽¹⁾	CONTROL BITS D3 TO D0			
	MODE 3	MODE 2	MODE 1	MODE 0
Mode 0: CVBS (automatic gain) from AI11 (pin 4)	0	0	0	0
Mode 1: CVBS (automatic gain) from AI12 (pin 7)	0	0	0	1
Mode 2: CVBS (automatic gain) from AI21 (pin 43)	0	0	1	0
Mode 3: CVBS (automatic gain) from AI22 (pin 1)	0	0	1	1
Mode 4: reserved	0	1	0	0
Mode 5: reserved	0	1	0	1
Mode 6: Y (automatic gain) from AI11 (pin 4) + C (gain adjustable via GAI28 to GAI20) from AI21 (pin 43); note 2	0	1	1	0
Mode 7: Y (automatic gain) from AI12 (pin 7) + C (gain adjustable via GAI28 to GAI20) from AI22 (pin 1); note 2	0	1	1	1
Mode 8: Y (automatic gain) from AI11 (pin 4) + C (gain adapted to Y gain) from AI21 (pin 43); note 2	1	0	0	0
Mode 9: Y (automatic gain) from AI12 (pin 7) + C (gain adapted to Y gain) from AI22 (pin 1); note 2	1	0	0	1
Modes 10 to 15: reserved	1	1	1	1

Notes

1. Mode select (see Figs 35 to 42).
2. To take full advantage of the YC-modes 6 to 9 the I²C-bus bit BYPS (subaddress 09H, bit 7) should be set to logic 1 (full luminance bandwidth).

15.2.2 SUBADDRESS 01H

Table 26 Horizontal increment delay

FUNCTION	IDEL3	IDEL2	IDEL1	IDEL0
No update	1	1	1	1
Minimum delay	1	1	1	0
Recommended position	1	0	0	0
Maximum delay	0	0	0	0

The programming of the horizontal increment delay is used to match internal processing delays to the delay of the ADC. Use recommended position only.

9-bit video input processor

SAA7113H

Table 28 Analog control 1 SA 02, D5 and D4 (see Fig.7)

UPDATE HYSTERESIS FOR 9-BIT GAIN	CONTROL BITS D5 AND D4	
	GUDL 1	GUDL 0
Off	0	0
±1 LSB	0	1
±2 LSB	1	0
±3 LSB	1	1

Table 29 Analog control 1 SA 02, D7 and D6 (see Fig.6)

ANALOG FUNCTION SELECT FUSE	CONTROL BITS D7 AND D6	
	FUSE 1	FUSE 0
Amplifier plus anti-alias filter bypassed	0	0
	0	1
Amplifier active	1	0
Amplifier plus anti-alias filter active	1	1

9-bit video input processor

SAA7113H

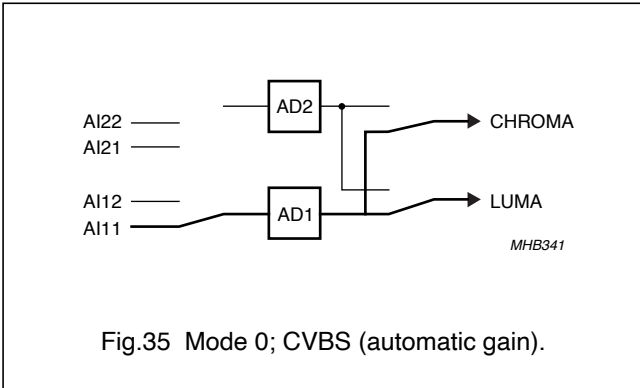

Fig.35 Mode 0; CVBS (automatic gain).

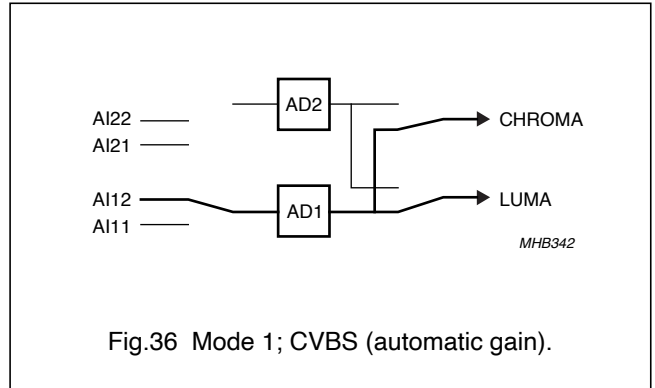

Fig.36 Mode 1; CVBS (automatic gain).

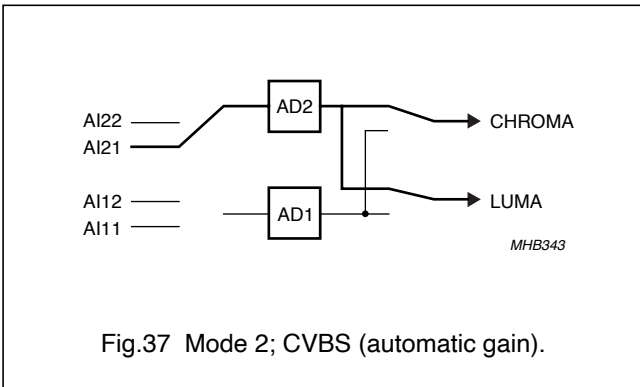

Fig.37 Mode 2; CVBS (automatic gain).

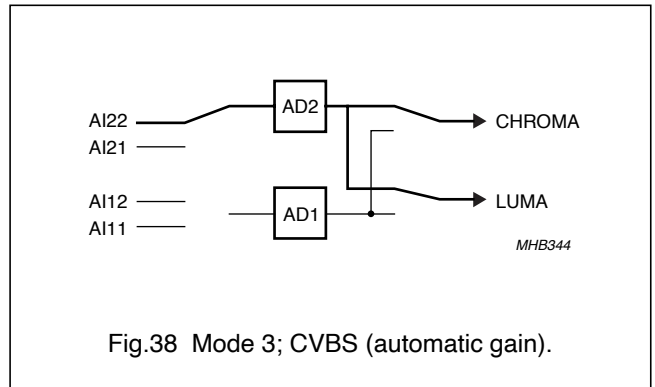

Fig.38 Mode 3; CVBS (automatic gain).

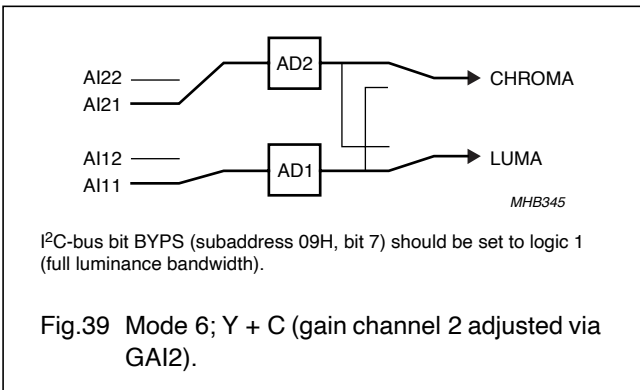

Fig.39 Mode 6; Y + C (gain channel 2 adjusted via GAI2).

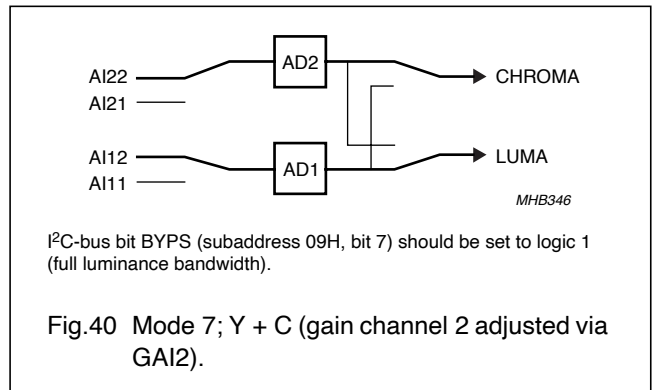

Fig.40 Mode 7; Y + C (gain channel 2 adjusted via GAI2).

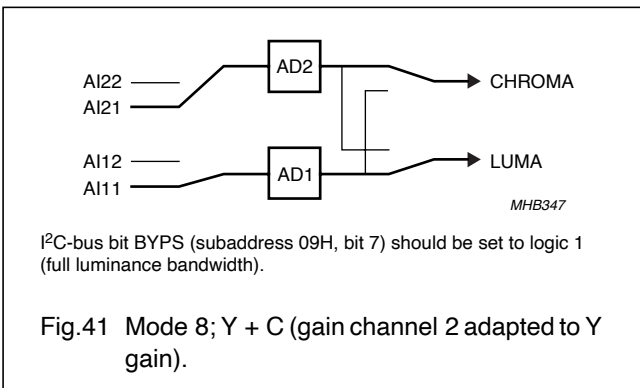

Fig.41 Mode 8; Y + C (gain channel 2 adapted to Y gain).

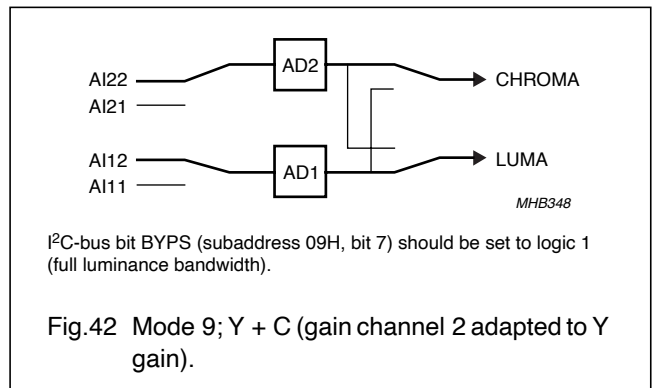

Fig.42 Mode 9; Y + C (gain channel 2 adapted to Y gain).

9-bit video input processor

SAA7113H

15.2.4 SUBADDRESS 03H

Table 30 Analog control 2 (AICO2) SA 03

FUNCTION	LOGIC LEVEL	DATA BIT
Static gain control channel 1 (GAI18) (see SA 04)		
Sign bit of gain control	see Table 31	D0
Static gain control channel 2 (GAI28) (see SA 05)		
Sign bit of gain control	see Table 32	D1
Gain control fix (GAFIX)		
Automatic gain controlled by MODE3 to MODE0	0	D2
Gain is user programmable via GAI1 + GAI2	1	D2
Automatic gain control integration (HOLDG)		
AGC active	0	D3
AGC integration hold (freeze)	1	D3
White peak off (WPOFF)		
White peak control active	0	D4
White peak off	1	D4
AGC hold during vertical blanking period (VBSL)		
Short vertical blanking (AGC disabled during equalization and serration pulses)	0	D5
Long vertical blanking (AGC disabled from start of pre-equalization pulses until start of active video (line 22 for 60 Hz, line 24 for 50 Hz))	1	D5
HL not reference select (HLNRS)		
Normal clamping if decoder is in unlocked state	0	D6
Reference select if decoder is in unlocked state	1	D6

15.2.5 SUBADDRESS 04H

Table 31 Gain control analog (AICO3); static gain control channel 1 GAI1 SA 04, D7 to D0

DECIMAL VALUE	GAIN (dB)	SIGN BIT	CONTROL BITS D7 TO D0							
		GAI18	GAI17	GAI16	GAI15	GAI14	GAI13	GAI12	GAI11	GAI10
0...	≈-3	0	0	0	0	0	0	0	0	0
...117...	≈0	0	0	1	1	1	0	1	0	1
...511	≈6	1	1	1	1	1	1	1	1	1

9-bit video input processor

SAA7113H

15.2.6 SUBADDRESS 05H

Table 32 Gain control analog (AICO4); static gain control channel 2 GAI2 SA 05, D7 to D0

DECIMAL VALUE	GAIN (dB)	SIGN BIT (SA 03, D1)	CONTROL BITS D7 TO D0							
			GAI28	GAI27	GAI26	GAI25	GAI24	GAI23	GAI22	GAI21
0...	≈-3	0	0	0	0	0	0	0	0	0
...117...	≈0	0	0	1	1	1	0	1	0	1
...511	≈6	1	1	1	1	1	1	1	1	1

15.2.7 SUBADDRESS 06H

Table 33 Horizontal sync begin SA 06, D7 to D0

DELAY TIME (STEP SIZE = 8/LLC)	CONTROL BITS D7 TO D0							
	HSB7	HSB6	HSB5	HSB4	HSB3	HSB2	HSB1	HSB0
-128...-109 (50 Hz)	forbidden (outside available central counter range)							
-128...-108 (60 Hz)								
-108 (50 Hz)...	1	0	0	1	0	1	0	0
-107 (60 Hz)...	1	0	0	1	0	1	0	1
...108 (50 Hz)	0	1	1	0	1	1	0	0
...107 (60 Hz)	0	1	1	0	1	0	1	1
109...127 (50 Hz)	forbidden (outside available central counter range)							
108...127 (60 Hz)								
Recommended value for raw data type; see Fig.24	1	1	1	0	1	0	0	1

15.2.8 SUBADDRESS 07H

Table 34 Horizontal sync stop SA 07, D7 to D0

DELAY TIME (STEP SIZE = 8/LLC)	CONTROL BITS D7 TO D0							
	HSS7	HSS6	HSS5	HSS4	HSS3	HSS2	HSS1	HSS0
-128...-109 (50 Hz)	forbidden (outside available central counter range)							
-128...-108 (60 Hz)								
-108 (50 Hz)...	1	0	0	1	0	1	0	0
-107 (60 Hz)...	1	0	0	1	0	1	0	1
...108 (50 Hz)	0	1	1	0	1	1	0	0
...107 (60 Hz)	0	1	1	0	1	0	1	1
109...127 (50 Hz)	forbidden (outside available central counter range)							
108...127 (60 Hz)								
Recommended value for raw data type; see Fig.24	0	0	0	0	1	1	0	1

9-bit video input processor

SAA7113H

15.2.9 SUBADDRESS 08H

Table 35 Sync control SA 08, D7 to D5, D3 to D0

FUNCTION	CONTROL BIT	LOGIC LEVEL	DATA BIT
Vertical noise reduction (VNOI)			
Normal mode (recommended setting)	VNOI1	0	D1
	VNOI0	0	D0
Fast mode [applicable for stable sources only; automatic field detection (AUFD) must be disabled]	VNOI1	0	D1
	VNOI0	1	D0
Free running mode	VNOI1	1	D1
	VNOI0	0	D0
Vertical noise reduction bypassed	VNOI1	1	D1
	VNOI0	1	D0
Horizontal PLL (HPLL)			
PLL closed	HPLL	0	D2
PLL open; horizontal frequency fixed	HPLL	1	D2
Horizontal time constant selection (HTC1 and HTC0)			
TV mode (recommended for poor quality TV signals only; do not use for new applications)	HTC1 and HTC0	00	D4 and D3
VTR mode (recommended if a deflection control circuit is directly connected to SAA7113H)	HTC1 and HTC0	01	D4 and D3
Reserved	HTC1 and HTC0	10	D4 and D3
Fast locking mode (recommended setting)	HTC1 and HTC0	11	D4 and D3
Forced ODD/EVEN toggle FOET			
ODD/EVEN signal toggles only with interlaced source	FOET	0	D5
ODD/EVEN signal toggles fieldwise even if source is non-interlaced	FOET	1	D5
Field selection (FSEL)			
50 Hz, 625 lines	FSEL	0	D6
60 Hz, 525 lines	FSEL	1	D6
Automatic field detection (AUFD)			
Field state directly controlled via FSEL	AUFD	0	D7
Automatic field detection	AUFD	1	D7

9-bit video input processor

SAA7113H

15.2.10 SUBADDRESS 09H

Table 36 Luminance control SA 09, D7 to D0

FUNCTION	APER/BPSS BIT	LOGIC LEVEL	DATA BIT
Aperture factor (APER); see Figs 12 to 17			
Aperture factor = 0	APER1	0	D1
	APER0	0	D0
Aperture factor = 0.25	APER1	0	D1
	APER0	1	D0
Aperture factor = 0.5	APER1	1	D1
	APER0	0	D0
Aperture factor = 1.0	APER1	1	D1
	APER0	1	D0
Update time interval for analog AGC value (UPTCV)			
Horizontal update (once per line)	UPTCV	0	D2
Vertical update (once per field)	UPTCV	1	D2
Vertical blanking luminance bypass (VBLB)			
Active luminance processing	VBLB	0	D3
Chrominance trap and peaking stage are disabled during VBI lines determined by VREF = 0; see Table 45	VBLB	1	D3
Aperture band-pass (centre frequency) (BPSS)			
Centre frequency = 4.1 MHz	BPSS1	0	D5
	BPSS0	0	D4
Centre frequency = 3.8 MHz; note 1	BPSS1	0	D5
	BPSS0	1	D4
Centre frequency = 2.6 MHz; note 1	BPSS1	1	D5
	BPSS0	0	D4
Centre frequency = 2.9 MHz; note 1	BPSS1	1	D5
	BPSS0	1	D4
Prefilter active (PREF); see Figs 12 to 17			
Bypassed	PREF	0	D6
Active	PREF	1	D6
Chrominance trap bypass (BYPS)			
Chrominance trap active; default for CVBS mode	BYPS	0	D7
Chrominance trap bypassed; default for S-video mode	BYPS	1	D7

Note

1. Not to be used with bypassed chrominance trap.

9-bit video input processor

SAA7113H

15.2.11 SUBADDRESS 0AH

Table 37 Luminance brightness control BRIG7 to BRIG0 SA 0A

OFFSET	CONTROL BITS D7 TO D0							
	BRIG7	BRIG6	BRIG5	BRIG4	BRIG3	BRIG2	BRIG1	BRIG0
255 (bright)	1	1	1	1	1	1	1	1
128 (CCIR level)	1	0	0	0	0	0	0	0
0 (dark)	0	0	0	0	0	0	0	0

15.2.12 SUBADDRESS 0BH

Table 38 Luminance contrast control CONT7 to CONT0 SA 0B

GAIN	CONTROL BITS D7 TO D0							
	CONT7	CONT6	CONT5	CONT4	CONT3	CONT2	CONT1	CONT0
1.999 (maximum)	0	1	1	1	1	1	1	1
1.109 (CCIR level)	0	1	0	0	0	1	1	1
1.0	0	1	0	0	0	0	0	0
0 (luminance off)	0	0	0	0	0	0	0	0
-1 (inverse luminance)	1	1	0	0	0	0	0	0
-2 (inverse luminance)	1	0	0	0	0	0	0	0

15.2.13 SUBADDRESS 0CH

Table 39 Chrominance saturation control SATN7 to SATN0 SA 0C

GAIN	CONTROL BITS D7 TO D0							
	SATN7	SATN6	SATN5	SATN4	SATN3	SATN2	SATN1	SATN0
1.999 (maximum)	0	1	1	1	1	1	1	1
1.0 (CCIR level)	0	1	0	0	0	0	0	0
0 (colour off)	0	0	0	0	0	0	0	0
-1 (inverse chrominance)	1	1	0	0	0	0	0	0
-2 (inverse chrominance)	1	0	0	0	0	0	0	0

15.2.14 SUBADDRESS 0DH

Table 40 Chrominance hue control HUEC7 to HUEC0 SA 0D

HUE PHASE (DEG)	CONTROL BITS D7 TO D0							
	HUEC7	HUEC6	HUEC5	HUEC4	HUEC3	HUEC2	HUEC1	HUEC0
+178.6...	0	1	1	1	1	1	1	1
...0...	0	0	0	0	0	0	0	0
...-180	1	0	0	0	0	0	0	0

9-bit video input processor

SAA7113H

15.2.15 SUBADDRESS 0EH

Table 41 Chrominance control SA 0E

FUNCTION		CHBW/CSTD BIT	LOGIC LEVEL	DATA BIT
50 Hz	60 Hz			
Chrominance bandwidth (CHBW0 and CHBW1)				
Small bandwidth (\approx 620 kHz)		CHBW1	0	D1
		CHBW0	0	D0
Nominal bandwidth (\approx 800 kHz)		CHBW1	0	D1
		CHBW0	1	D0
Medium bandwidth (\approx 920 kHz)		CHBW1	1	D1
		CHBW0	0	D0
Wide bandwidth (\approx 1 000 kHz)		CHBW1	1	D1
		CHBW0	1	D0
Fast colour time constant (FCTC)				
Nominal time constant		FCTC	0	D2
Fast time constant		FCTC	1	D2
Disable chrominance comb filter (DCCF)				
Chrominance comb filter on (during lines determined by VREF = 1; see Table 45)		DCCF	0	D3
Chrominance comb filter permanently off		DCCF	1	D3
Colour standard selection (CSTD0 to CSTD2); logic levels 100, 110 and 111 are reserved, do not use				
PAL BGHIN	NTSC M (or NTSC-Japan with special level adjustment: brightness subaddress 0AH = 95H; contrast subaddress 0BH = 48H)	CSTD2	0	D6
		CSTD1	0	D5
		CSTD0	0	D4
NTSC 4.43 (50 Hz)	PAL 4.43 (60 Hz)	CSTD2	0	D6
		CSTD1	0	D5
		CSTD0	1	D4
Combination-PAL N	NTSC 4.43 (60 Hz)	CSTD2	0	D6
		CSTD1	1	D5
		CSTD0	0	D4
NTSC N	PAL M	CSTD2	0	D6
		CSTD1	1	D5
		CSTD0	1	D4
SECAM	reserved	CSTD2	1	D6
		CSTD1	0	D5
		CSTD0	1	D4

9-bit video input processor

SAA7113H

FUNCTION		CHBW/CSTD BIT	LOGIC LEVEL	DATA BIT
50 Hz	60 Hz			
Clear DTO (CDTO)				
Disabled		CDTO	0	D7
Every time CDTO is set, the internal subcarrier DTO phase is reset to 0° and the RTCO output generates a logic 0 at time slot 68 (see external document “ <i>RTC Functional Description</i> ”, available on request). So an identical subcarrier phase can be generated by an external device (e.g. an encoder).		CDTO	1	D7

15.2.16 SUBADDRESS 0FH

Table 42 Chrominance gain control SA 0F (D6 to D0)

CHROMINANCE GAIN VALUE (IF ACGC IS SET TO LOGIC 1)	CONTROL BITS D6 TO D0						
	CGAIN6	CGAIN5	CGAIN4	CGAIN3	CGAIN2	CGAIN1	CGAIN0
Minimum gain (0.5)	0	0	0	0	0	0	0
Nominal gain (1.125)	0	1	0	0	1	0	0
Maximum gain (7.5)	1	1	1	1	1	1	1

Table 43 Chrominance gain control SA 0F (D7)

AUTOMATIC CHROMINANCE GAIN CONTROL ACGC	D7
	ACGC
On	0
Programmable gain via CGAIN6 to CGAIN0	1

15.2.17 SUBADDRESS 10H

Table 44 Format/delay control SA 10 (D2 to D0)

LUMINANCE DELAY COMPENSATION (STEPS IN 2/LLC)	CONTROL BITS D2 TO D0		
	YDEL2	YDEL1	YDEL0
-4...	1	0	0
...0...	0	0	0
...3	0	1	1

9-bit video input processor

SAA7113H

Table 45 VREF pulse position and length VRLN SA 10 (D3)

VRLN	VREF AT 60 Hz 525 LINES				VREF AT 50 Hz 625 LINES			
	0		1		0		1	
Length	240		242		286		288	
Line number	first	last	first	last	first	last	first	last
Field 1 ⁽¹⁾	19 (22)	258 (261)	18 (21)	259 (262)	24	309	23	310
Field 2 ⁽¹⁾	282 (285)	521 (524)	281 (284)	522 (525)	337	622	336	623

Note

1. The numbers given in parenthesis refer to ITU line counting.

Table 46 Fine position of HS HDEL0 and HDEL1 SA 10 (D5 and D4)

FINE POSITION OF HS (STEPS IN 2/LLC)	CONTROL BITS D5 AND D4	
	HDEL1	HDEL0
0	0	0
1	0	1
2	1	0
3	1	1

Table 47 Output format selection OFTS0 and OFTS1 SA 10 (D7 and D6); see Tables 6 and 7

V-FLAG GENERATION IN SAV/EAV-CODES	CONTROL BITS D7 AND D6	
	OFTS1	OFTS0
Standard ITU 656-format	0	0
V-flag in SAV/EAV is generated by VREF	0	1
V-flag in SAV/EAV is generated by data-type	1	0
Reserved	1	1

9-bit video input processor

SAA7113H

15.2.18 SUBADDRESS 11H

Table 48 Output control 1 SA 11

FUNCTION	BIT	LOGIC LEVEL	DATA BIT
Colour on (COLO)			
Automatic colour killer	COLO	0	D0
Colour forced on	COLO	1	D0
YUV decoder bypassed (VIPB)			
Processed data to VPO output	VIPB	0	D1
ADC data to VPO output; dependent on mode settings	VIPB	1	D1
Output enable real-time (OERT)			
RTS0, RTS1, RTCO high-impedance inputs	OERT	0	D2
RTS0, RTCO active, RTS1 active, if RTSE13 to RTSE10 = 0000	OERT	1	D2
Output enable YUV data (OEYC)			
VPO-bus high-impedance	OEYC	0	D3
Output VPO-bus active or controlled by RTS1; see Table 19	OEYC	1	D3
Selection of horizontal lock indicator for RTS0, RTS1 outputs			
Standard horizontal lock indicator (low-passed)	HLSEL	0	D4
Fast lock indicator (use is recommended only for high performance input signals)	HLSEL	1	D4
General purpose switch [available on pin RTS0, if control byte RTSE03 to RTSE00 (subaddress 12H) is set to 0010]			
LOW	GPSW0	0	D5
HIGH	GPSW0	1	D5
CM99 compatibility to SAA7199 (CM99)			
Default value	CM99	0	D6
To be set only if SAA7199 (digital encoder) is used for re-encoding in conjunction with RTCO	CM99	1	D6
General purpose switch [available on pin RTS1, if control byte RTS103 to RTS100 (subaddress 12H) is set to 0010]			
LOW	GPSW1	0	D7
HIGH	GPSW1	1	D7

9-bit video input processor

SAA7113H

15.2.19 SUBADDRESS 12H

Table 49 RTS0 output control SA 12

RTS0 OUTPUT CONTROL	D3 TO D0			
	RTSE03	RTSE02	RTSE01	RTSE00
Reserved	0	0	0	0
VIPB (subaddress 11H bit 1) = 0: reserved	0	0	0	1
VIPB (subaddress 11H bit 1) = 1: LSBs of the 9-bit ADCs				
GPSW0 level (subaddress 11H, bit 5)	0	0	1	0
HL (horizontal lock indicator); selectable via HLSEL (subaddress 11H, bit 4) HSEL = 0: standard horizontal lock indicator HSEL = 1: fast horizontal lock indicator (use is not recommended for sources with unstable timebase e.g. VCRs)	0	0	1	1
VL (vertical and horizontal lock)	0	1	0	0
DL (vertical and horizontal lock and colour detected)	0	1	0	1
PLIN (PAL/SECAM sequence; LOW: PAL/DR line is present)	0	1	1	0
HREF_HS, horizontal reference signal: indicates valid data on the VPO-bus. The positive slope marks the beginning of a new active line. The pulse width is dependent on the data type selected by the control registers LCR2 to LCR24 (subaddress 41H to 57H; see Tables 4 and 61) data type 0 to 6 8 to 15: HIGH period 1440 LLC-cycles (720 samples; see Fig.28) data type 7 (upsampled raw data): HIGH period programmable in LLC8 steps via HSB7 to HSB0, HSS7 to HSS0 (subaddress 06H and 07H), fine position adjustment via HDEL1 to HDEL0 (subaddress 10H, bits 5 and 4)	0	1	1	1
HS, programmable width in LLC8 steps via HSB7 to HSB0 and HSS7 to HSS0 (subaddress 06H and 07H), fine position adjustment in LLC2 steps via HDEL1 to HDEL0 (subaddress 10H, bits 5 and 4)	1	0	0	0
HQ (HREF gated with VREF)	1	0	0	1
ODD, field identifier; HIGH = odd field; see vertical timing diagrams Figs 29 and 30	1	0	1	0
VS (vertical sync; see vertical timing diagrams Figs 29 and 30)	1	0	1	1
V123 (vertical pulse; see vertical timing diagrams Figs 29 and 30)	1	1	0	0
VGATE (programmable via VSTA8 to VSTA0 and VSTO8 to VSTO0, subaddresses 15H, 16H and 17H)	1	1	0	1
VREF (programmable in two positions via VRLN, subaddress 10H, bit 3)	1	1	1	0
FID (position and polarity programmable via VSTA8 to VSTA0, subaddresses 15H and 17H and FIDP, subaddress 13H bit 3)	1	1	1	1

9-bit video input processor

SAA7113H

Table 50 RTS1 output control SA 12

RTS1 OUTPUT CONTROL	D7 TO D4			
	RTSE13	RTSE12	RTSE11	RTSE10
3-state, pin RTS1 is used as DOT input; see Table 19	0	0	0	0
VIPB (subaddress 11H bit 1) = 0: reserved	0	0	0	1
VIPB (subaddress 11H bit 1) = 1: LSBs of the 9-bit ADCs				
GPSW1	0	0	1	0
HL (horizontal lock indicator); selectable via HLSEL (subaddress 11H, bit 4) HLSEL = 0: standard horizontal lock indicator HLSEL = 1: fast horizontal lock indicator (use is not recommended for sources with unstable timebase e. g. VCRs)	0	0	1	1
VL (vertical and horizontal lock)	0	1	0	0
DL (vertical and horizontal lock and colour detected)	0	1	0	1
PLIN (PAL/SECAM sequence; LOW: PAL/DR line is present)	0	1	1	0
HREF_HS, horizontal reference signal: indicates valid data on the VPO-bus. The positive slope marks the beginning of a new active line. The pulse width is dependent on the data type selected by the control registers LCR2 to LCR24 (subaddress 41H to 57H; see Tables 4 and 61) data type 0 to 6, 8 to 15: HIGH period 1440 LLC-cycles (720 samples; see Fig.28) data type 7 (upsampled raw data): HIGH period programmable in LLC8 steps via HSB7 to HSB0, HSS7 to HSS0 (subaddress 06H and 07H), fine position adjustment via HDEL1 to HDEL0 (subaddress 10H, bits 5 and 4)	0	1	1	1
HS, programmable width in LLC8 steps via HSB7 to HSB0 and HSS7 to HSS0 (subaddress 06H and 07H), fine position adjustment in LLC2 steps via HDEL1 to HDEL0 (subaddress 10H, bits 5 and 4)	1	0	0	0
HQ (HREF gated with VREF)	1	0	0	1
ODD, field identifier; HIGH = odd field; see vertical timing diagrams Figs 29 and 30	1	0	1	0
VS (vertical sync); see vertical timing diagrams Figs 29 and 30	1	0	1	1
V123 (vertical pulse); see vertical timing diagrams Figs 29 and 30	1	1	0	0
VGATE (programmable via VSTA8 to VSTA0 and VSTO8 to VSTO0, subaddresses 15H, 16H and 17H)	1	1	0	1
VREF (programmable in two positions via VRLN, subaddress 10H, bit 3)	1	1	1	0
FID (position and polarity programmable via VSTA 8 to VSTA0, subaddresses 15H and 17H and FIDP, subaddress 13 bit 3)	1	1	1	1

9-bit video input processor

SAA7113H

15.2.20 SUBADDRESS 13H

Table 51 Output control SA 13, D7, D4, D3, D1 and D0

FUNCTION	BIT	LOGIC LEVEL	DATA BIT
Analog test select (AOSL)			
AOUT connected to internal test point 1	AOSL1	0	D1
	AOSL0	0	D0
AOUT connected to input AD1	AOSL1	0	D1
	AOSL0	1	D0
AOUT connected to input AD2	AOSL1	1	D1
	AOSL0	0	D0
AOUT connected to internal test point 2	AOSL1	1	D1
	AOSL0	1	D0
Field ID polarity if selected on RTS1 or RTS0 outputs if RTSE1, RTSE0 (subaddress 12H) are set to 1111			
Default	FIDP	0	D3
Inverted	FIDP	1	D3
Selection bit for status byte functionality OLDSB			
Default status information; see Table 55	OLDSB	0	D4
Old status information, for compatibility reasons; see Table 55	OLDSB	1	D4
Analog-to-digital converter output bits on VPO7 to VPO0 in bypass mode (VIPB = 1, used for test purposes) ADLSB; note 1			
AD8 to AD1 (MSBs) on VPO7 to VPO0	ADLSB	0	D7
AD7 to AD0 (LSBs) on VPO7 to VPO0	ADLSB	1	D7

Note

1. Analog-to-digital converter selection via MODE3 to MODE0 (subaddress 02H; see Figs 35 to 38).

9-bit video input processor

SAA7113H

15.2.21 SUBADDRESS 15H

Table 52 Start of VGATE pulse (01-transition) and polarity change of FID pulse

FIELD	FRAME LINE COUNTING	DECIMAL VALUE	MSB (SA 17, D0)	CONTROL BITS D7 TO D0								
			VSTA8	VSTA7	VSTA6	VSTA5	VSTA4	VSTA3	VSTA2	VSTA1	VSTA0	
50 Hz	1st	1	312	1	0	0	1	1	1	0	0	0
	2nd	314										
	1st	2	0...	0	0	0	0	0	0	0	0	0
	2nd	315										
	1st	312	...310	1	0	0	1	1	0	1	1	1
	2nd	625										
60 Hz	1st	4	262	1	0	0	0	0	0	1	1	0
	2nd	267										
	1st	5	0...	0	0	0	0	0	0	0	0	0
	2nd	268										
	1st	265	...260	1	0	0	0	0	0	1	0	1
	2nd	3										

9-bit video input processor

SAA7113H

15.2.22 SUBADDRESS 16H

Table 53 Stop of VGATE pulse (10-transition)

FIELD	FRAME LINE COUNTING	DECIMAL VALUE	MSB (SA 17, D0)	CONTROL BITS D7 TO D0									
			VSTO8	VSTO7	VSTO6	VSTO5	VSTO4	VSTO3	VSTO2	VSTO1	VSTO0		
50 Hz	1st	1	312	1	0	0	1	1	1	0	0	0	
	2nd	314											
	1st	2	0...	0	0	0	0	0	0	0	0	0	
	2nd	315											
	1st	312	...310	1	0	0	1	1	0	1	1	1	
	2nd	625											
60 Hz	1st	4	262	1	0	0	0	0	0	0	1	1	0
	2nd	267											
	1st	5	0...	0	0	0	0	0	0	0	0	0	0
	2nd	268											
	1st	265	...260	1	0	0	0	0	0	1	0	1	
	2nd	3											

9-bit video input processor

SAA7113H

15.2.23 SUBADDRESS 17H

Table 54 VGATE MSBs

FUNCTION	LOGIC LEVEL	CONTROL BIT
VSTA8, see SA 15		
MSB VGATE start	see Table 52	D0
VSTO8, see SA 16		
MSB VGATE stop	see Table 53	D1

15.2.24 SUBADDRESS 1FH (READ ONLY REGISTER)

Table 55 Status byte video decoder SA 1F

I ² C-BUS CONTROL BIT	FUNCTION	DATA BIT
RDCAP	ready for capture (all internal loops locked); active HIGH (OLDSB = 0)	D0
CODE	colour signal in accordance with selected standard has been detected; active HIGH (OLDSB = 1)	
COPRO	copy protected source detected according to macrovision version up to 7.01 (OLDSB = 0)	D1
SLTCA	slow time constant active in WIPA mode; active HIGH (OLDSB = 1)	
WIPA	white peak loop is activated; active HIGH	D2
GLIMB	gain value for active luminance channel is limited [min (bottom)]; active HIGH	D3
GLIMT	gain value for active luminance channel is limited [max (top)]; active HIGH	D4
FIDT	identification bit for detected field frequency; LOW = 50 Hz, HIGH = 60 Hz	D5
HLVLN	status bit for horizontal/vertical loop: LOW = locked, HIGH = unlocked (OLDSB = 0)	D6
HLCK	status bit for locked horizontal frequency; LOW = locked, HIGH = unlocked (OLDSB = 1)	
INTL	status bit for interlace detection; LOW = non-interlaced, HIGH = interlaced	D7

15.2.25 SUBADDRESS 40H

Table 56 Data slicer clock selection

SLICER SET (40H)	CONTROL BITS D2 AND D1	
AMPLITUDE SEARCHING	CLKSEL1	CLKSEL0
Reserved	00	
13.5 MHz (default)	01	
Reserved	10	
Reserved	11	

Table 57 Amplitude searching

SLICER SET (40H)	CONTROL BIT D4
AMPLITUDE SEARCHING	HUNT_N
Amplitude searching active (default)	0
Amplitude searching stopped	1

9-bit video input processor

SAA7113H

Table 58 Framing code error

SLICER SET (40H)	CONTROL BIT D5
FRAMING CODE ERROR	FCE
One framing code error allowed	0
No framing code errors allowed	1

Table 59 Hamming check

SLICER SET (40H)	CONTROL BIT D6
HAMMING CHECK	HAM_N
Hamming check for 2 bytes after framing code, dependent on data type (default)	0
No hamming check	1

Table 60 Field size select

SLICER SET (40H)	CONTROL BIT D7
FIELD SIZE SELECT	FISET
50 Hz field rate	0
60 Hz field rate	1

9-bit video input processor

SAA7113H

15.2.26 SUBADDRESS 41H TO 57H

Table 61 LCR register 2 to 24 (41H to 57H); see Table 4

LCR REGISTER 2 TO 24 (41H TO 57H)		FRAMING CODE	D7 TO D4	D3 TO D0
			DT3 TO DT0 ⁽¹⁾	DT3 TO DT0 ⁽¹⁾
WST625	teletext EuroWST, CCST	27H	0000	0000
CC625	European closed caption	001	0001	0001
VPS	video programming service	9951H	0010	0010
WSS	wide screen signalling bits	1E3C1FH	0011	0011
WST525	US teletext (WST)	27H	0100	0100
CC525	US closed caption (line 21)	001	0101	0101
Test line	video component signal, VBI region	–	0110	0110
Intercast	oversampled CVBS data	–	0111	0111
General text	teletext	programmable	1000	1000
VITC625	VITC/EBU time codes (Europe)	programmable	1001	1001
	VITC/SMPTE time codes (USA)	programmable	1010	1010
Reserved	reserved	–	1011	1011
NABTS	US NABTS	–	1100	1100
Japtext	MOJI (Japanese)	programmable (A7H)	1101	1101
JFS	Japanese format switch (L20/22)	programmable	1110	1110
Active video	video component signal, active video region (default)	–	1111	1111

Note

1. The assignment of the upper and lower nibbles to the corresponding field depends on the setting of FOFF (subaddress 5B, D7); see Table 62.

Table 62 Setting of FOFF

FOFF	D7 TO D4	D3 TO D0
0	field 1	field 2
1	field 2	field 1

9-bit video input processor

SAA7113H

15.2.27 SUBADDRESS 58H

Table 63 Framing code for programmable data types

SLICER SET (58H)	CONTROL BITS D7 TO D0
PROGRAMMABLE FRAMING CODE	FC7 TO FC0
(Default)	40H

15.2.28 SUBADDRESS 59H

Table 64 Horizontal offset

SLICER SET (59H, 5BH)	CONTROL BITS ADDRESS 5BH, DATA BITS D2 TO D0	CONTROL BITS ADDRESS 59H, DATA BITS D7 TO D0
HORIZONTAL OFFSET	HOFF10 TO HOFF8	HOFF7 TO HOFF0
Recommended value	3H	54H

15.2.29 SUBADDRESS 5AH

Table 65 Vertical offset

SLICER SET (5AH, 5BH)	CONTROL BIT 5BH, D4	CONTROL BITS ADDRESS 5AH, DATA BITS D7 TO D0
VERTICAL OFFSET	VOFF8	VOFF7 TO VOFF0
Minimum value 0	0	0H
Maximum value 312	1	38H
Value for 50 Hz 625 lines input	0	07H
Value for 60 Hz 525 lines input	0	0AH

15.2.30 SUBADDRESS 5BH

Table 66 Field offset, MSBs for vertical and horizontal offsets

SLICER SET (5BH)	CONTROL BIT D7
FIELD OFFSET	FOFF
No modification of internal field indicator	0
Invert field indicator (even/odd; default)	1

15.2.31 SUBADDRESS 5EH

Table 67 SDID codes

SLICER SET (5EH)	D5	D4	D3	D2	D1	D0
SDID codes	SDID5	SDID4	SDID3	SDID2	SDID1	SDID0
SDID5 to SDID0 = 0H (default)	0	0	0	0	0	0

9-bit video input processor

SAA7113H

15.2.32 SUBADDRESS 60H (READ-ONLY REGISTER)

Table 68 Slicer status bit (60H) read only

SLICER STATUS BIT (60H) READ ONLY	CONTROL BIT D2
CLOSED CAPTION VALID	CCV
No closed caption in the last frame	0
Closed caption detected	1

Table 69 Slicer status bit (60H) read only

SLICER STATUS BIT (60H) READ ONLY	CONTROL BIT D3
PALplus VALID	PPV
No PALplus in the last frame	0
PALplus detected	1

Table 70 Slicer status bit (60H) read only

SLICER STATUS BIT (60H) READ ONLY	CONTROL BIT D4
VPS VALID	VPSV
No VPS in the last frame	0
VPS detected	1

Table 71 Slicer status bit (60H) read only

SLICER STATUS BIT (60H) READ ONLY	CONTROL BITS D6 AND D5	
	FC8V	FC7V
FRAMING CODE VALID		
No framing code in the last frame	0	0
Framing code with 1 error detected in the last frame	0	1
Framing code without errors detected in the last frame	1	X ⁽¹⁾

Note

1. X = don't care.

15.2.33 SUBADDRESS 61H (READ-ONLY REGISTER)

Table 72 Slicer status bits (61H and 62H) read only

SLICER STATUS BITS (61H AND 62H) READ ONLY	ADDRESS 61H, CONTROL BITS D4 TO D0	ADDRESS 62H, CONTROL BITS D7 TO D4
Line number	LN8 to LN4	LN3 to LN0

15.2.34 SUBADDRESS 62H (READ-ONLY REGISTER)

Table 73 Slicer status bits (62H) read only

SLICER STATUS BITS (62H) READ ONLY	CONTROL BITS D3 TO D0
Data type according to Table 4	DT3 to DT0

9-bit video input processor

SAA7113H

16 I²C-BUS START SET-UP

The given values force the following behaviour of the SAA7113H:

- The analog input AI11 expects a signal in CVBS format; analog anti-alias filter and AGC active
- Automatic field detection enabled, PAL BDGHI or NTSC M standard expected
- Standard ITU 656 output format enabled, VBI-data slicer disabled; see Table 74 note 2
- Contrast, brightness and saturation control in accordance with ITU standards
- Chrominance processing with nominal bandwidth (800 kHz).

Table 74 I²C-bus start set-up values

SUB (HEX)	FUNCTION	NAME ⁽¹⁾	VALUES (BIN)								(HEX)
			7	6	5	4	3	2	1	0	START
00	chip version	ID07 to ID00	read only								
01	increment delay	X, X, X, X, IDEL	0	0	0	0	1	0	0	0	08
02	analog input control 1	FUSE1 and FUSE0, GUDL1 to GUDL0, MODE3 to MODE0	1	1	0	0	0	0	0	0	C0
03	analog input control 2	X, HLNRS, VBSL, WPOFF, HOLDG, GAFIX, GAI28 and GAI18	0	0	1	1	0	0	1	1	33
04	analog input control 3	GAI17 to GAI10	0	0	0	0	0	0	0	0	00
05	analog input control 4	GAI27 to GAI20	0	0	0	0	0	0	0	0	00
06	horizontal sync start	HSB7 to HSB0	1	1	1	0	1	0	0	1	E9
07	horizontal sync stop	HSS7 to HSS0	0	0	0	0	1	1	0	1	0D
08	sync control	AUFD, FSEL, FOET, HTC1, HTC0, HPLL, VNOI1 and VNOI0	1	0	0	1	1	0	0	0	98
09	luminance control	BYPS, PREF, BPSS1 and BPSS0, VBLB, UPTCV, APER1 and APER0	0	0	0	0	0	0	0	1	01
0A	luminance brightness	BRIG7 to BRIG0	1	0	0	0	0	0	0	0	80
0B	luminance contrast	CONT7 to CONT0	0	1	0	0	0	1	1	1	47
0C	chrominance saturation	SATN7 to SATN0	0	1	0	0	0	0	0	0	40
0D	chrominance hue control	HUEC7 to HUEC0	0	0	0	0	0	0	0	0	00
0E	chrominance control	CDTO, CSTD2 to CSTD0, DCCF, FCTC, CHBW1 and CHBW0	0	0	0	0	0	0	0	1	01
0F	chrominance gain control	ACGC, CGAIN6 to CGAIN0	0	0	1	0	1	0	1	0	2A
10	format/delay control	OFTS1 and OFTS0, HDEL1 and HDEL0, VRLN, YDEL2 to YDEL0	0	0	0	0	0	0	0	0	00
11	output control 1	GPSW1, CM99, GPSW0, HLSEL, OEYC, OERT, VIPB and COLO	0	0	0	0	1	1	0	0	0C
12	output control 2	RTSE13 to RTSE10, RTSE03 to RTSE00	0	0	0	0	0	0	0	1	01
13	output control 3	ADLSB, X, X, OLDSB, FIDP, X, AOSL1 and AOSL0	0	0	0	0	0	0	0	0	00
14	reserved		0	0	0	0	0	0	0	0	00

9-bit video input processor

SAA7113H

SUB (HEX)	FUNCTION	NAME ⁽¹⁾	VALUES (BIN)							(HEX)	
			7	6	5	4	3	2	1	0	START
15	VGATE start	VSTA7 to VSTA0	0	0	0	0	0	0	0	0	00
16	VGATE stop	VSTO7 to VSTO0	0	0	0	0	0	0	0	0	00
17	MSBs for VGATE control	X, X, X, X, X, X, VSTO8 and VSTA8	0	0	0	0	0	0	0	0	00
18 to 1E	reserved		0	0	0	0	0	0	0	0	00
1F	decoder status byte	INTL, HVLN, FIDT, GLIMIT, GLIMB, WIPA, COPRP and RDCAP	read-only register								
20 to 3F	reserved		0	0	0	0	0	0	0	0	00
40	slicer control 1	FISET, HAM_N, FCE and HUNT_N	0	0	0	0	0	0	1	0	02 ⁽²⁾
41 to 57	line control register 2 to 24	LCRn7 to LCRn0	1	1	1	1	1	1	1	1	FF ⁽²⁾
58	programmable framing code	FC7 to FC0	0	0	0	0	0	0	0	0	00
59	horizontal offset for slicer	HOFF7 to HOFF0	0	1	0	1	0	1	0	0	54 ⁽²⁾
5A	vertical offset for slicer	VOFF7 to VOFF0	0	0	0	0	0	1	1	1	07 ⁽²⁾
5B	field offset and MSBs for horizontal and vertical offset	FOFF, X, X, VOFF8, X, HOFF10 to HOFF8	1	0	0	0	0	0	1	1	83 ⁽²⁾
5C and 5D	reserved		0	0	0	0	0	0	0	0	00
5E	sliced data identification code	X, X, SDID5 to SDID0	0	0	0	0	0	0	0	0	00
5F	reserved		0	0	0	0	0	0	0	0	00
60	slicer status byte 1	X, FC8V, FC7V, VPSV, PPV, CCV, X, X	read-only register								
61	slicer status byte 2	X, X, F21_N, LN8 to LN4	read-only register								
62		LN3 to LN0, DT3 to DT0	read-only register								

Notes

1. All X values must be set to LOW. For SECAM decoding set register 0EH to 50H.
2. For proper data slicer programming refer to Tables 8 to 11 and 4.

9-bit video input processor

SAA7113H

17 PACKAGE OUTLINE

QFP44: plastic quad flat package; 44 leads (lead length 1.3 mm); body 10 x 10 x 1.75 mm

SOT307-2

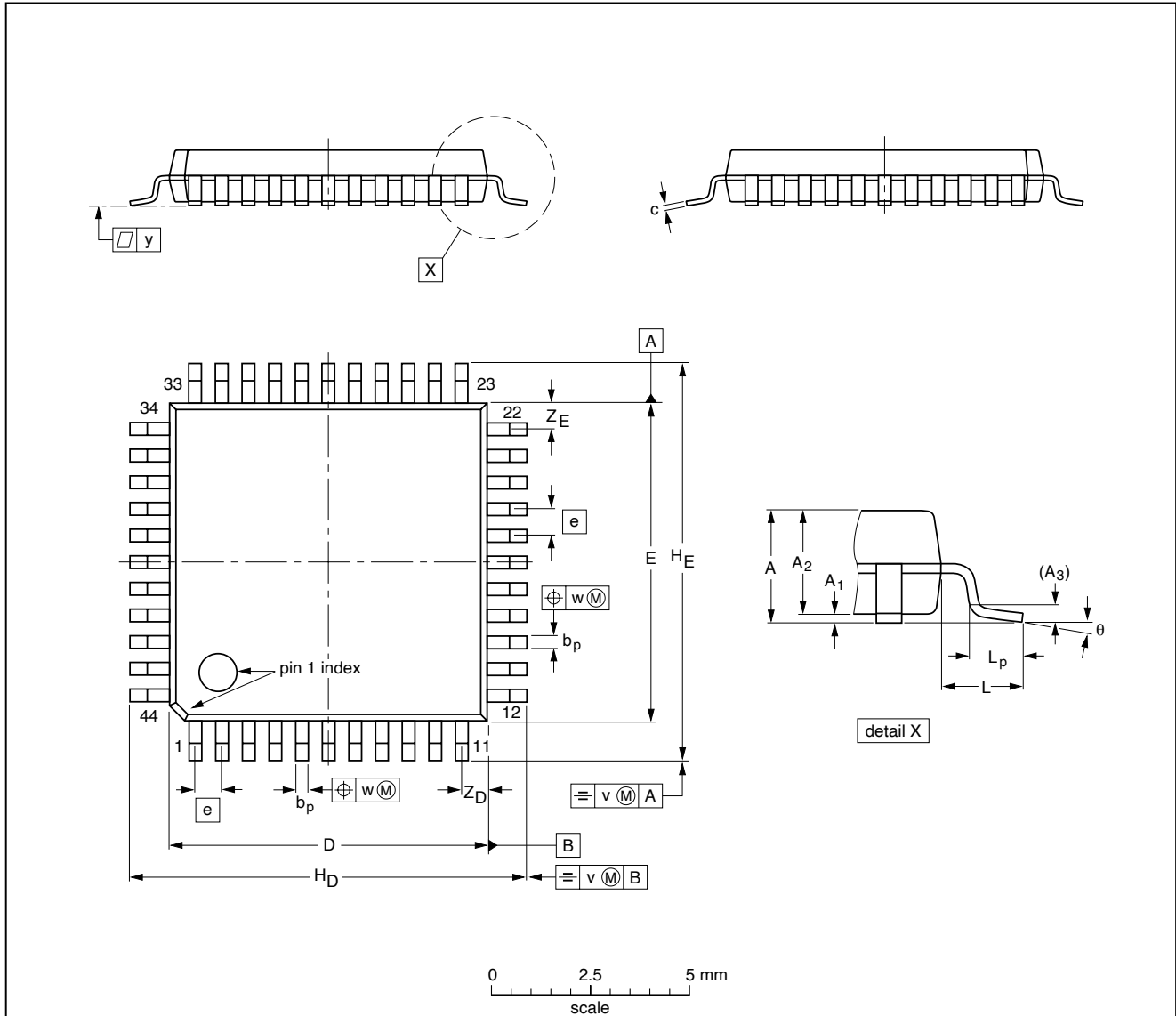

DIMENSIONS (mm are the original dimensions)

UNIT	A max.	A ₁	A ₂	A ₃	b _p	c	D ⁽¹⁾	E ⁽¹⁾	e	H _D	H _E	L	L _p	v	w	y	Z _D ⁽¹⁾	Z _E ⁽¹⁾	θ
mm	2.10	0.25 0.05	1.85 1.65	0.25	0.40 0.20	0.25 0.14	10.1 9.9	10.1 9.9	0.8	12.9 12.3	12.9 12.3	1.3	0.95 0.55	0.15	0.15	0.1	1.2 0.8	1.2 0.8	10° 0°

Note

1. Plastic or metal protrusions of 0.25 mm maximum per side are not included.

OUTLINE VERSION	REFERENCES				EUROPEAN PROJECTION	ISSUE DATE
	IEC	JEDEC	EIAJ			
SOT307-2						95-02-04 97-08-01

9-bit video input processor

SAA7113H

18 SOLDERING

18.1 Introduction to soldering surface mount packages

This text gives a very brief insight to a complex technology. A more in-depth account of soldering ICs can be found in our *"Data Handbook IC26; Integrated Circuit Packages"* (document order number 9398 652 90011).

There is no soldering method that is ideal for all surface mount IC packages. Wave soldering is not always suitable for surface mount ICs, or for printed-circuit boards with high population densities. In these situations reflow soldering is often used.

18.2 Reflow soldering

Reflow soldering requires solder paste (a suspension of fine solder particles, flux and binding agent) to be applied to the printed-circuit board by screen printing, stencilling or pressure-syringe dispensing before package placement.

Several methods exist for reflowing; for example, infrared/convection heating in a conveyor type oven. Throughput times (preheating, soldering and cooling) vary between 100 and 200 seconds depending on heating method.

Typical reflow peak temperatures range from 215 to 250 °C. The top-surface temperature of the packages should preferably be kept below 230 °C.

18.3 Wave soldering

Conventional single wave soldering is not recommended for surface mount devices (SMDs) or printed-circuit boards with a high component density, as solder bridging and non-wetting can present major problems.

To overcome these problems the double-wave soldering method was specifically developed.

If wave soldering is used the following conditions must be observed for optimal results:

- Use a double-wave soldering method comprising a turbulent wave with high upward pressure followed by a smooth laminar wave.
- For packages with leads on two sides and a pitch (e):
 - larger than or equal to 1.27 mm, the footprint longitudinal axis is **preferred** to be parallel to the transport direction of the printed-circuit board;
 - smaller than 1.27 mm, the footprint longitudinal axis **must** be parallel to the transport direction of the printed-circuit board.

The footprint must incorporate solder thieves at the downstream end.
- For packages with leads on four sides, the footprint must be placed at a 45° angle to the transport direction of the printed-circuit board. The footprint must incorporate solder thieves downstream and at the side corners.

During placement and before soldering, the package must be fixed with a droplet of adhesive. The adhesive can be applied by screen printing, pin transfer or syringe dispensing. The package can be soldered after the adhesive is cured.

Typical dwell time is 4 seconds at 250 °C. A mildly-activated flux will eliminate the need for removal of corrosive residues in most applications.

18.4 Manual soldering

Fix the component by first soldering two diagonally-opposite end leads. Use a low voltage (24 V or less) soldering iron applied to the flat part of the lead. Contact time must be limited to 10 seconds at up to 300 °C.

When using a dedicated tool, all other leads can be soldered in one operation within 2 to 5 seconds between 270 and 320 °C.

9-bit video input processor

SAA7113H

18.5 Suitability of surface mount IC packages for wave and reflow soldering methods

PACKAGE	SOLDERING METHOD	
	WAVE	REFLOW ⁽¹⁾
BGA, SQFP	not suitable	suitable
HLQFP, HSQFP, HSOP, SMS	not suitable ⁽²⁾	suitable
PLCC ⁽³⁾ , SO, SOJ	suitable	suitable
LQFP, QFP, TQFP	not recommended ⁽³⁾⁽⁴⁾	suitable
SSOP, TSSOP, VSO	not recommended ⁽⁵⁾	suitable

Notes

1. All surface mount (SMD) packages are moisture sensitive. Depending upon the moisture content, the maximum temperature (with respect to time) and body size of the package, there is a risk that internal or external package cracks may occur due to vaporization of the moisture in them (the so called popcorn effect). For details, refer to the Drypack information in the *"Data Handbook IC26; Integrated Circuit Packages; Section: Packing Methods"*.
2. These packages are not suitable for wave soldering as a solder joint between the printed-circuit board and heatsink (at bottom version) can not be achieved, and as solder may stick to the heatsink (on top version).
3. If wave soldering is considered, then the package must be placed at a 45° angle to the solder wave direction. The package footprint must incorporate solder thieves downstream and at the side corners.
4. Wave soldering is only suitable for LQFP, TQFP and QFP packages with a pitch (e) equal to or larger than 0.8 mm; it is definitely not suitable for packages with a pitch (e) equal to or smaller than 0.65 mm.
5. Wave soldering is only suitable for SSOP and TSSOP packages with a pitch (e) equal to or larger than 0.65 mm; it is definitely not suitable for packages with a pitch (e) equal to or smaller than 0.5 mm.

9-bit video input processor

SAA7113H

19 DEFINITIONS

Data sheet status	
Objective specification	This data sheet contains target or goal specifications for product development.
Preliminary specification	This data sheet contains preliminary data; supplementary data may be published later.
Product specification	This data sheet contains final product specifications.
Limiting values	
Limiting values given are in accordance with the Absolute Maximum Rating System (IEC 134). Stress above one or more of the limiting values may cause permanent damage to the device. These are stress ratings only and operation of the device at these or at any other conditions above those given in the Characteristics sections of the specification is not implied. Exposure to limiting values for extended periods may affect device reliability.	
Application information	
Where application information is given, it is advisory and does not form part of the specification.	

20 LIFE SUPPORT APPLICATIONS

These products are not designed for use in life support appliances, devices, or systems where malfunction of these products can reasonably be expected to result in personal injury. Philips customers using or selling these products for use in such applications do so at their own risk and agree to fully indemnify Philips for any damages resulting from such improper use or sale.

21 PURCHASE OF PHILIPS I²C COMPONENTS

Purchase of Philips I²C components conveys a license under the Philips' I²C patent to use the components in the I²C system provided the system conforms to the I²C specification defined by Philips. This specification can be ordered using the code 9398 393 40011.

9-bit video input processor

SAA7113H

NOTES

Philips Semiconductors – a worldwide company

Argentina: see South America

Australia: 34 Waterloo Road, NORTH RYDE, NSW 2113,
Tel. +61 2 9805 4455, Fax. +61 2 9805 4466

Austria: Computerstr. 6, A-1101 WIEN, P.O. Box 213,
Tel. +43 1 60 101 1248, Fax. +43 1 60 101 1210

Belarus: Hotel Minsk Business Center, Bld. 3, r. 1211, Volodarski Str. 6,
220050 MINSK, Tel. +375 172 20 0733, Fax. +375 172 20 0773

Belgium: see The Netherlands

Brazil: see South America

Bulgaria: Philips Bulgaria Ltd., Energoproject, 15th floor,
51 James Bourchier Blvd., 1407 SOFIA,
Tel. +359 2 68 9211, Fax. +359 2 68 9102

Canada: PHILIPS SEMICONDUCTORS/COMPONENTS,
Tel. +1 800 234 7381, Fax. +1 800 943 0087

China/Hong Kong: 501 Hong Kong Industrial Technology Centre,
72 Tat Chee Avenue, Kowloon Tong, HONG KONG,
Tel. +852 2319 7888, Fax. +852 2319 7700

Colombia: see South America

Czech Republic: see Austria

Denmark: Sydhavnsgade 23, 1780 COPENHAGEN V,
Tel. +45 33 29 3333, Fax. +45 33 29 3905

Finland: Sinikalliontie 3, FIN-02630 ESPOO,
Tel. +358 9 615 800, Fax. +358 9 6158 0920

France: 51 Rue Carnot, BP317, 92156 SURESNES Cedex,
Tel. +33 1 4099 6161, Fax. +33 1 4099 6427

Germany: Hammerbrookstraße 69, D-20097 HAMBURG,
Tel. +49 40 2353 60, Fax. +49 40 2353 6300

Hungary: see Austria

India: Philips INDIA Ltd, Band Box Building, 2nd floor,
254-D, Dr. Annie Besant Road, Worli, MUMBAI 400 025,
Tel. +91 22 493 8541, Fax. +91 22 493 0966

Indonesia: PT Philips Development Corporation, Semiconductors Division,
Gedung Philips, Jl. Buncit Raya Kav.99-100, JAKARTA 12510,
Tel. +62 21 794 0040 ext. 2501, Fax. +62 21 794 0080

Ireland: Newstead, Clonskeagh, DUBLIN 14,
Tel. +353 1 7640 000, Fax. +353 1 7640 200

Israel: RAPAC Electronics, 7 Kehilat Saloniki St, PO Box 18053,
TEL AVIV 61180, Tel. +972 3 645 0444, Fax. +972 3 649 1007

Italy: PHILIPS SEMICONDUCTORS, Piazza IV Novembre 3,
20124 MILANO, Tel. +39 02 67 52 2531, Fax. +39 02 67 52 2557

Japan: Philips Bldg 13-37, Kohnan 2-chome, Minato-ku,
TOKYO 108-8507, Tel. +81 3 3740 5130, Fax. +81 3 3740 5057

Korea: Philips House, 260-199 Itaewon-dong, Yongsan-ku, SEOUL,
Tel. +82 2 709 1412, Fax. +82 2 709 1415

Malaysia: No. 76 Jalan Universiti, 46200 PETALING JAYA, SELANGOR,
Tel. +60 3 750 5214, Fax. +60 3 757 4880

Mexico: 5900 Gateway East, Suite 200, EL PASO, TEXAS 79905,
Tel. +9-5 800 234 7381, Fax +9-5 800 943 0087

Middle East: see Italy

Netherlands: Postbus 90050, 5600 PB EINDHOVEN, Bldg. VB,
Tel. +31 40 27 82785, Fax. +31 40 27 88399

New Zealand: 2 Wagener Place, C.P.O. Box 1041, AUCKLAND,
Tel. +64 9 849 4160, Fax. +64 9 849 7811

Norway: Box 1, Manglerud 0612, OSLO,
Tel. +47 22 74 8000, Fax. +47 22 74 8341

Pakistan: see Singapore

Philippines: Philips Semiconductors Philippines Inc.,
106 Valero St. Salcedo Village, P.O. Box 2108 MCC, MAKATI,
Metro MANILA, Tel. +63 2 816 6380, Fax. +63 2 817 3474

Poland: Ul. Lukiska 10, PL 04-123 WARSZAWA,
Tel. +48 22 612 2831, Fax. +48 22 612 2327

Portugal: see Spain

Romania: see Italy

Russia: Philips Russia, Ul. Usatcheva 35A, 119048 MOSCOW,
Tel. +7 095 755 6918, Fax. +7 095 755 6919

Singapore: Lorong 1, Toa Payoh, SINGAPORE 319762,
Tel. +65 350 2538, Fax. +65 251 6500

Slovakia: see Austria

Slovenia: see Italy

South Africa: S.A. PHILIPS Pty Ltd., 195-215 Main Road Martindale,
2092 JOHANNESBURG, P.O. Box 58088 Newville 2114,
Tel. +27 11 471 5401, Fax. +27 11 471 5398

South America: Al. Vicente Pinzon, 173, 6th floor,
04547-130 SÃO PAULO, SP, Brazil,
Tel. +55 11 821 2333, Fax. +55 11 821 2382

Spain: Balmes 22, 08007 BARCELONA,
Tel. +34 93 301 6312, Fax. +34 93 301 4107

Sweden: Kottbygatan 7, Akalla, S-16485 STOCKHOLM,
Tel. +46 8 5985 2000, Fax. +46 8 5985 2745

Switzerland: Allmendstrasse 140, CH-8027 ZÜRICH,
Tel. +41 1 488 2741 Fax. +41 1 488 3263

Taiwan: Philips Semiconductors, 6F, No. 96, Chien Kuo N. Rd., Sec. 1,
TAIPEI, Taiwan Tel. +886 2 2134 2886, Fax. +886 2 2134 2874

Thailand: PHILIPS ELECTRONICS (THAILAND) Ltd.,
209/2 Sanpavuth-Bangna Road Prakanong, BANGKOK 10260,
Tel. +66 2 745 4090, Fax. +66 2 398 0793

Turkey: Yukari Dudullu, Org. San. Blg., 2.Cad. Nr. 28 81260 Umraniye,
ISTANBUL, Tel. +90 216 522 1500, Fax. +90 216 522 1813

Ukraine: PHILIPS UKRAINE, 4 Patrice Lumumba str., Building B, Floor 7,
252042 KIEV, Tel. +380 44 264 2776, Fax. +380 44 268 0461

United Kingdom: Philips Semiconductors Ltd., 276 Bath Road, Hayes,
MIDDLESEX UB3 5BX, Tel. +44 208 730 5000, Fax. +44 208 754 8421

United States: 811 East Arques Avenue, SUNNYVALE, CA 94088-3409,
Tel. +1 800 234 7381, Fax. +1 800 943 0087

Uruguay: see South America

Vietnam: see Singapore

Yugoslavia: PHILIPS, Trg N. Pasica 5/v, 11000 BEOGRAD,
Tel. +381 11 62 5344, Fax. +381 11 63 5777

For all other countries apply to: Philips Semiconductors,
International Marketing & Sales Communications, Building BE-p, P.O. Box 218,
5600 MD EINDHOVEN, The Netherlands, Fax. +31 40 27 24825

Internet: <http://www.semiconductors.philips.com>

© Philips Electronics N.V. 1999

SCA 66

All rights are reserved. Reproduction in whole or in part is prohibited without the prior written consent of the copyright owner.

The information presented in this document does not form part of any quotation or contract, is believed to be accurate and reliable and may be changed without notice. No liability will be accepted by the publisher for any consequence of its use. Publication thereof does not convey nor imply any license under patent- or other industrial or intellectual property rights.

Printed in The Netherlands

545006/01/pp80

Date of release: 1999 Jul 01

Document order number: 9397 750 04567

Let's make things better.

Philips
Semiconductors



PHILIPS