

LM2416/LM2416C Triple 50 MHz CRT Driver

General Description

The LM2416 contains three wide bandwidth, large signal amplifiers designed for large voltage swings. The amplifiers have a gain of -13 . The device is intended for use in color CRT monitors and is a low cost solution to designs conforming to VGA, Super VGA and the IBM® 8514 graphics standard.

The part is housed in the industry standard 11-lead TO-220 molded power package. The heat sink is floating and may be grounded for ease of manufacturing and RFI shielding.

Features

- 50 Vpp output at 45 MHz drives CRT directly
- Rise/fall time typically 8 ns with 8 pF load
- 65V output swing capability

Applications

- CRT driver for RGB monitors
- High voltage amplifiers

Schematic and Connection Diagram

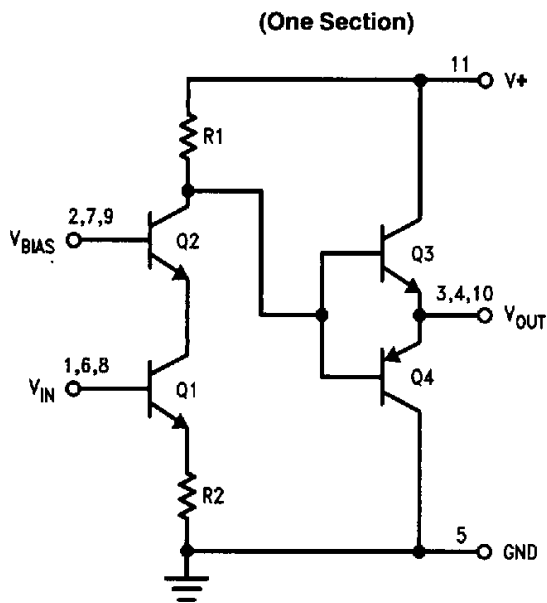

TL/K/10738-1

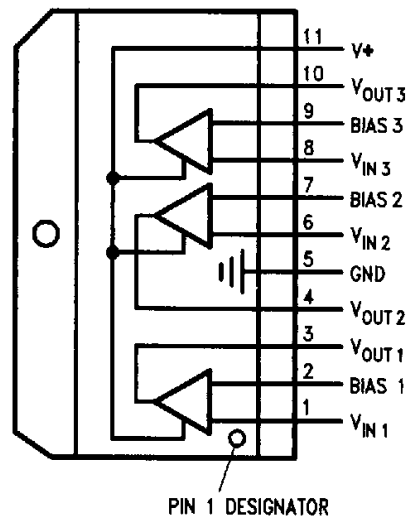

TL/K/10738-2

Top View

Order Number LM2416T or LM2416CT
See NS Package Number TA11B

Absolute Maximum Ratings

Supply Voltage, V+	+85V
Power Dissipation, P _D	10W
Storage Temperature Range, T _{STG}	-25°C to +100°C
Operating Temperature Range, T _{CASE}	-20°C to +90°C
Lead Temperature (Soldering, <10 sec.)	300°C
ESD Tolerance	4 kV

If Military/Aerospace specified devices are required, please contact the National Semiconductor Sales Office/Distributors for availability and specifications.

Electrical Characteristics

V+ = 80V, C_L = 8 pF, DC input bias, V_{IN} = 3.6 V_{DC}. 50 V_{pp} output swing, V_{BIAS} = +12V. See Figure 1. T_A = 25°C unless otherwise noted.

Symbol	Parameter	Conditions	LM2416			LM2416C			Units
			Min	Typical	Max	Min	Typ	Max	
I _{CC}	Supply Current (per Amplifier)	No Input or Output Load	18	22	26	16	22	28	mA
V _{OUT}	Output Offset Voltage	V _{IN} = 3.6V	38	42	46	35	42	48	V _{DC}
t _r	Rise Time	10% to 90% (Note 3)		8	13		12	16	ns
t _f	Fall Time	10% to 90% (Note 3)		8	13		12	16	ns
BW	Bandwidth	-3 dB		42			35		MHz
A _v	Voltage Gain		-11	-13	-15	-10	-13	-16	V/V
OS	Overshoot	Figure 1		0			0		%
LE	Linearity Error	(Note 1)		8			10		%
ΔA _v	Gain Matching	(Note 2)		0.2			0.5		dB

Note 1: Linearity Error is defined as the variation in small signal gain from +20V to +70V output with a 100 mV AC, 1 MHz, input signal.

Note 2: Calculated value from Voltage Gain test on each channel.

Note 3: Guaranteed parameter, not tested.

Test Circuit

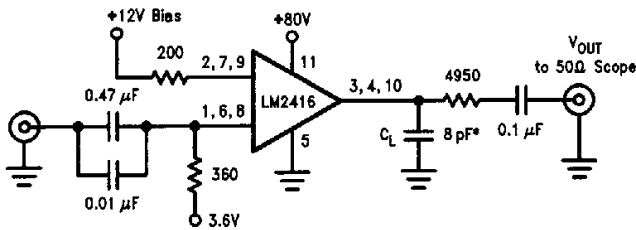

TL/K/10738-3

* 8 pF is total load capacitance. It includes all parasitic capacitance.

FIGURE 1. Test Circuit (One Section)

Figure 1 shows a typical test circuit for evaluation of the LM2416. This circuit is designed to allow testing of the LM2416 in a 50Ω environment such as a pulse generator, oscilloscope or network analyzer.

Typical Performance Characteristics

LM2416 Frequency Response

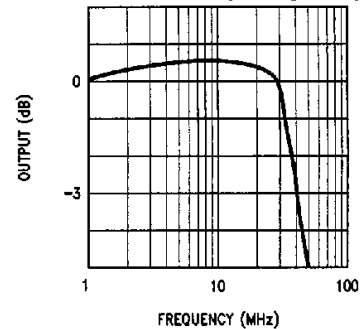

TL/K/10738-4

LM2416 Pulse Response

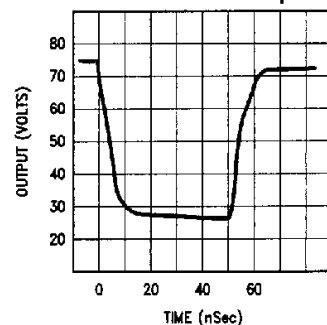

TL/K/10738-5

LM2416—Theory of Operation

The LM2416 is a high voltage triple CRT driver suitable for VGA, Super VGA, IBM 8514 and 1K by 768 non-interlaced display applications. The LM2416 features 80 volt operation and low power dissipation. The part is housed in the industry standard 11 lead TO-220 molded power package. The heat sink is floating and may be grounded for ease of manufacturing and RFI shielding.

The circuit diagram of the LM2416 is shown in *Figure 2*. Q1 and R2 provides a conversion of input voltage to current, while Q2 acts as a common base or cascode amplifier stage to drive the load resistor R1. Emitter followers Q3 and Q4 isolate the impedance of R1 from the capacitance of the CRT cathode, and make the circuit relatively insensitive to load capacitance. The gain of this circuit is $-R1/R2$ and is fixed at -13 . The bandwidth of the circuit is set by the collector time constant formed by the load resistor R1 and associated capacitance of Q2, Q3, Q4, and stray layout capacitance. Proprietary transistor design allows for high bandwidth with low operating power.

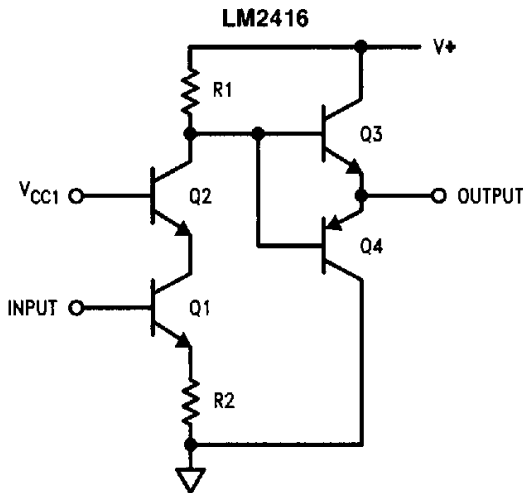

FIGURE 2. LM2416 CRT Driver
(One Section)

TL/K/10738-6

Thermal Considerations

The transfer characteristics of the amplifier are shown in *Figure 3*. Power supply current increases as the input signal increases and consequently power dissipation also increases.

The LM2416 cannot be used without heat sinking. *Figure 3* shows the power dissipated in each channel over the operating voltage range of the device. Typical "average" power dissipation with the device output voltage at one half the supply voltage is 1.8W per channel for a total dissipation of 5.4W package dissipation. Under white screen conditions, i.e.: 15V output, dissipation increases to 3W per channel or 9W total. The LM2416 case temperature must be maintained below 90°C. If the maximum expected ambient temperature is 50°C, then a heat sink is needed with thermal resistance equal to or less than:

$$R_{th} = \frac{(90 - 50^{\circ}\text{C})}{9\text{W}} = 4.4^{\circ}\text{C/W}$$

The Thermalloy #6400 is one example of a heatsink that meets this requirement.

WARNING: THE LM2416 IS NOT PROTECTED AGAINST OUTPUT SHORT CIRCUITS. The minimum resistance the LM2416 can drive is 600Ω to ground or V+.

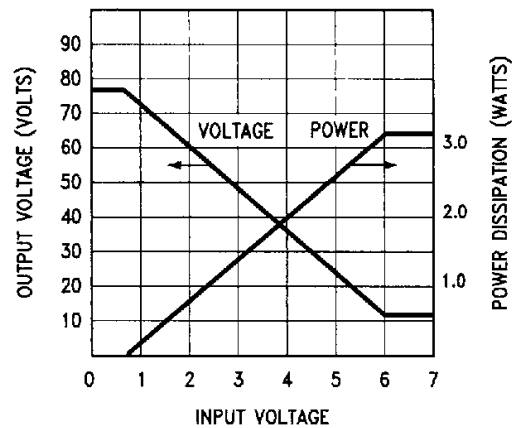

TL/K/10738-7

FIGURE 3. LM2416 DC Characteristics

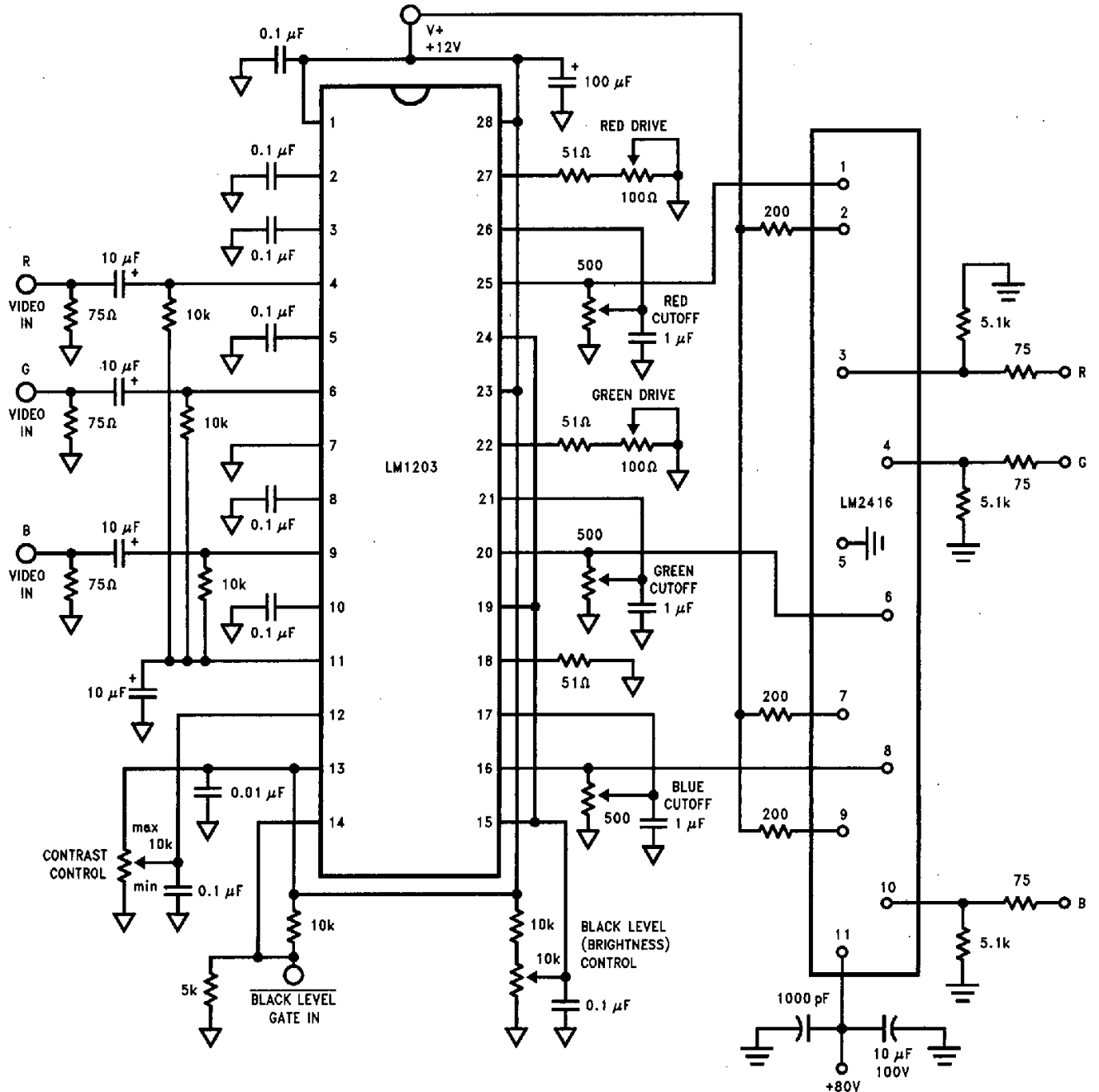

TL/K/10738-8

FIGURE 4. Typical Application LM1203-LM2416 Application

A typical application of the LM2416 is shown in *Figure 4*. Used in conjunction with a LM1203, a complete video channel from monitor input to CRT cathode is shown. Performance is satisfactory for all applications to 1k by 768 non-interlaced. Typical rise-fall times are 12 ns, with better than 50V p-p drive signals available to an 8 pF load. In this

application, feedback is local to the LM1203. An alternative scheme would be feedback from the output of the LM2416 to the positive clamp inputs of the LM1203. This would provide slightly better black level control of the system.