

4-CH MOTOR DRIVER

The KA3010D is a monolithic integrated circuit, and suitable for 4-CH motor driver which drives tracking actuator, focus actuator, sled motor and loading motor of CD/CD-ROM/DVD system, and can also drive spindle motor of CD system.

FEATURES

- 1-phase, full-wave, linear DC motor driver
- Wide dynamic range:
 - $V_{CC}=5V, R_L=8\Omega \rightarrow V_{OM}=3.0V$
 - $V_{CC}=12V, R_L=24\Omega \rightarrow V_{OM}=9.5V$
- Output gain adjustable
- Built in op-amp
- Built in mute function
- Built in level shift circuit
- Built in thermal shutdown function

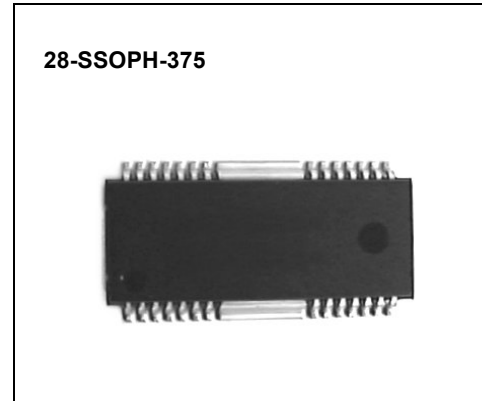

ORDERING INFORMATION

Device	Package	Operating Temperature
KA3010D	28-SSOPH-375	-20°C ~ +75°C

BLOCK DIAGRAM

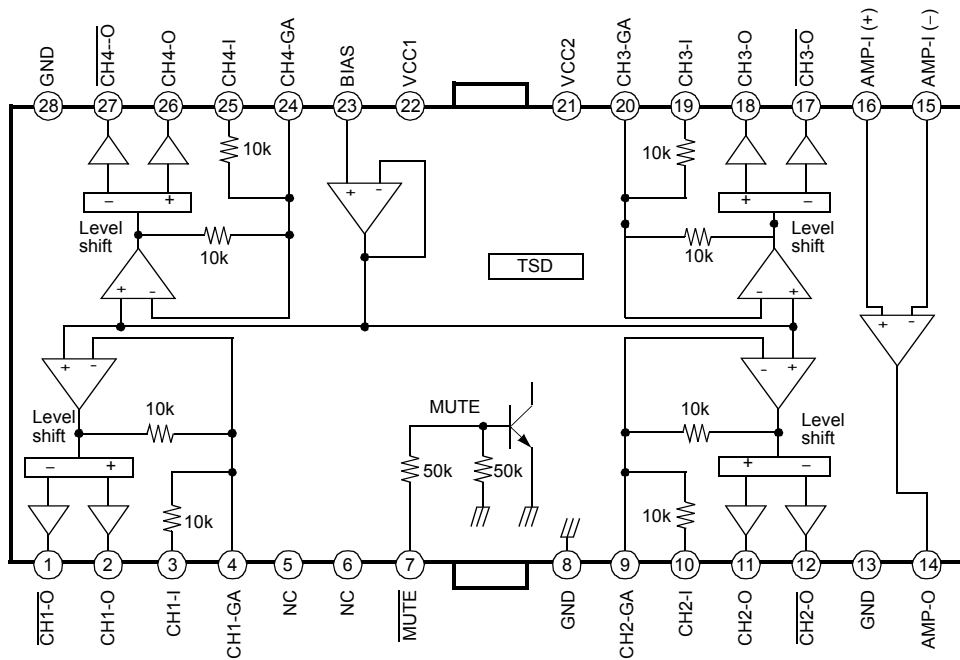

PIN CONFIGURATION

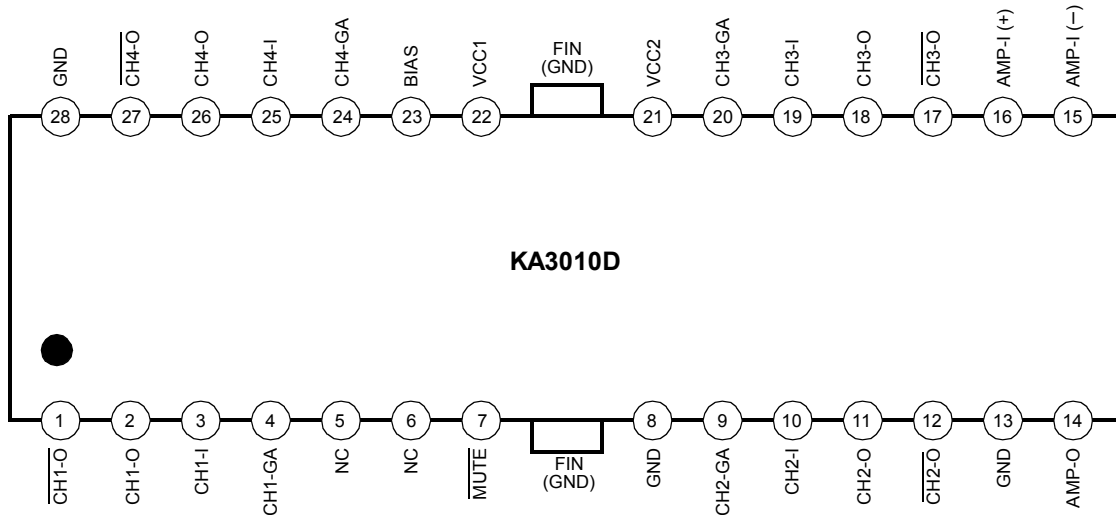

PIN DESCRIPTION

Pin No.	Symbol	I/O	Description	Pin No.	Symbol	I/O	Description
1	CH1-O	O	Drive CH 1 output (-)	15	AMP-1 (-)	I	Op-amp input (-)
2	CH1-O	O	Drive CH 1 output (+)	16	AMP-1 (+)	I	Op-amp input (+)
3	CH1-I	I	Drive CH 1 input	17	CH3-O	O	Drive CH 3 output (-)
4	CH1-GA	I	Drive CH1 input (Adjustable)	18	CH3-O	O	Drive CH 3 output (+)
5	NC	-	No connection	19	CH3-I	I	Drive CH 3 input
6	NC	-	No connection	20	CH3-GA	I	Drive CH 3 input (Adjustable)
7	MUTE	I	Mute	21	VCC2	-	Supply voltage 2
8	GND	-	Signal ground	22	VCC1	-	Supply voltage 1
9	CH2-GA	I	Drive CH 2 input (Adjustable)	23	BIAS	I	2.5V bias
10	CH2-I	I	Drive CH 2 input	24	CH4-GA	I	Drive CH 4 input (Adjustable)
11	CH2-O	O	Drive CH 2 output (+)	25	CH4-I	I	Drive CH 4 input
12	CH2-O	O	Drive CH 2 output (-)	26	CH4-O	O	Drive CH 4 output (+)
13	GND	-	Power ground	27	CH4-O	O	Drive CH 4 output (-)
14	AMP-O	O	Op-amp output	28	GND	-	Power ground

EQUIVALENT CIRCUITS

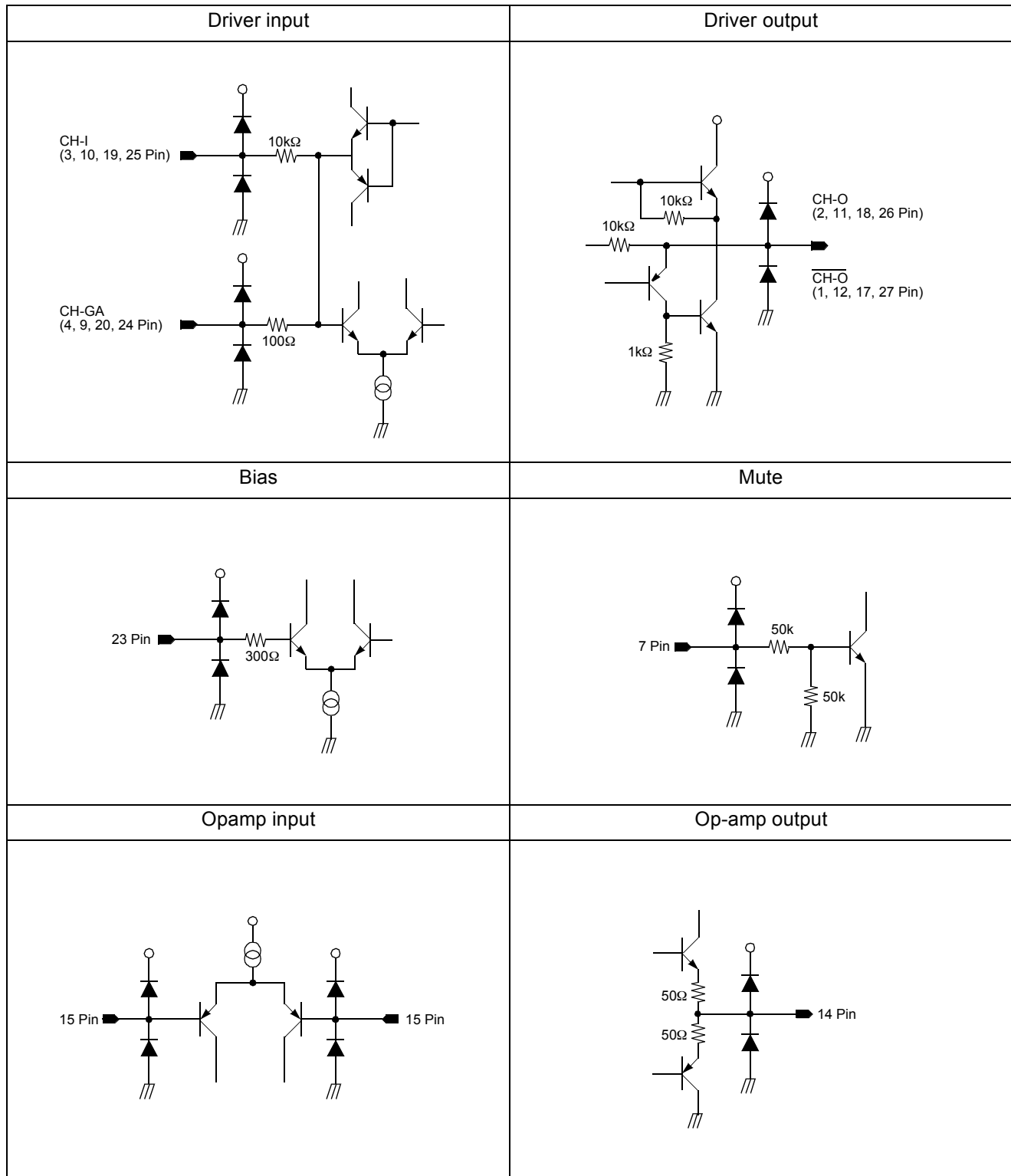

ABSOLUTE MAXIMUM RATING (T_a=25°C)

Characteristics	Symbol	Value	Unit
Maximum supply voltage	V _{CC1} , V _{CC2}	15	V
Power dissipation	P _D	1.7 ^{note}	W
Operating temperature	T _{OPR}	-20 ~ +75	°C
Storage temperature	T _{STG}	-55 ~ +150	°C

NOTE:

1. When mounted on 50mm × 50mm × 1mm PCB (Phenolic resin material).
2. Power dissipation reduces 13.6mW / °C for using above T_a=25°C.
3. Do not exceed P_d and SOA.

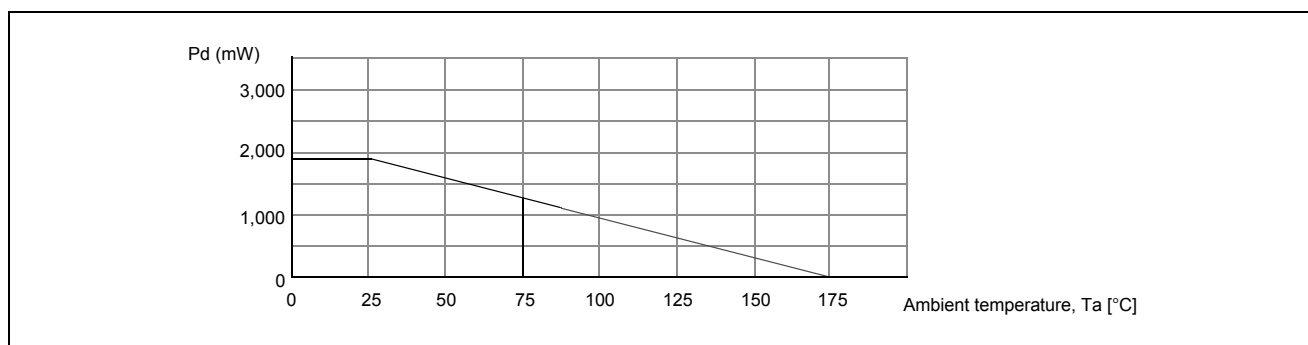
**RECOMMENDED OPERATING CONDITION (T_a=25°C)**

Characteristics	Symbol	Min.	Typ.	Max.	Unit
Supply voltage	V _{CC1} , V _{CC2}	4.5	–	13	V
Operating temperature	T _{OPR}	-25	–	+75	°C

ELECTRICAL CHARACTERISTICS

(Ta=25°C, V_{CC1}=V_{CC2}=5V, R_L=8Ω)

Characteristic	Symbol	Test conditions	Min.	Typ.	Max.	Unit
DRIVE PART						
Quiescent current	I _{CC}	–	–	9	12	mA
Output offset voltage	V _{OO}	–	–50	0	50	mV
Maximum output voltage	V _{OM}	–	2.0	3.0	–	V
		V _{CC1} =V _{CC2} =12V, R _L =24Ω	6.5	9.5	–	V
Voltage gain	G _{VC}	V _{IN} =0.1V _{RMS} , 1kHz	10.5	12.0	13.5	dB
Ripple rejection ratio	RR	V _{IN} =0.1V _{RMS} , 120Hz	–	50	–	dB
Slew rate	SR	120Hz, 2V _{P-P}	–	0.8	–	V / μs
		V _{CC1} & 2=12V, 120Hz, 4V _{p-p}	–	1.0	–	V / μs
Mute off voltage	V _{MOFF}	–	2.0	–	–	V
Mute on voltage	V _{MON}	–	–	–	0.5	V
OP-AMP PART						
Input offset voltage	V _{OFOP}	–	–10	0	10	mV
Input bias current	I _{BOP}	–	–	–	300	nA
High level output voltage	V _{OHOP}	–	3	3.9	–	V
		V _{CC1} =V _{CC2} =12V	10	10.9	–	V
Low level output voltage	V _{OLOP}	–	–	1.1	1.8	V
Output sink current	I _{SINK}	R _L =50Ω	10	30	–	mA
		V _{CC1} =V _{CC2} =12V, R _L =50Ω	10	95	–	mA
Output source current	I _{SOURCE}	R _L =50Ω	10	30	–	mA
		V _{CC1} =V _{CC2} =12V, R _L =50Ω	10	50	–	mA
Voltage gain	G _{VO}	V _{IN} = –75dB, 1kHz	–	78	–	dB
Slew rate	SR _{OP}	100Hz, 2V _{p-p}	–	2	–	V / μs
Ripple rejection ratio	RR _{OP}	V _{IN} = –20dB, 120kHz	–	65	–	dB
Common-mode rejection ratio	CMRR	V _{IN} = –20dB, 1kHz	–	84	–	dB

APPLICATION INFORMATION

1. MUTEM

Pin #7	Mute circuit
High	Turn-off
Low	Turn-on
Open	Turn-on

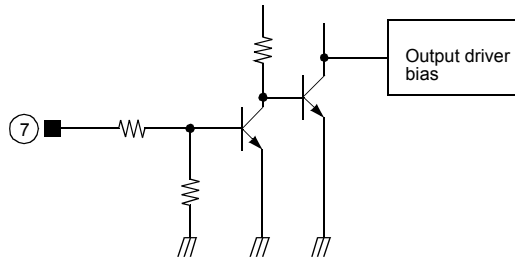

- When the mute pin #7 is open or the voltage of the mute pin #7 is below 0.5V, the mute circuit is activated so that the output circuit will be muted.
- When the voltage of the mute pin is above 2V, the mute circuit is stopped and the output circuit is operated normally.
- If the chip temperature rises above 175°C, then the TSD (Thermal shutdown) circuit is activated and the output circuit is muted.

2. TSD (THERMAL SHUTDOWN)

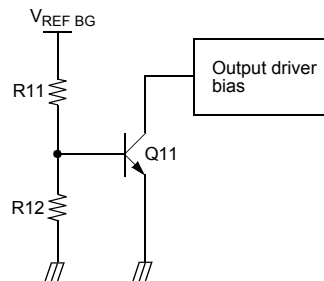

- The $V_{REF\ BG}$ is the output voltage of the band-gap-referenced bias in circuit and acts as the input voltage of the TSD circuit.
- The base-emitter voltage of the TR, Q11 is designed to turn-on at below voltage.

$$V_{BE} = V_{REF\ BG} \times R12 / (R11 + R12) = 460mV$$
- When the chip temperature rises up to 175°C, then the turn-on voltage of the Q11 would drop down to 460mV. (Hysteresis: 25°C) Hence, the Q11 would turn on so the output circuit will be muted.

3. OP-AMP

Op-amp is integrated in the IC for user's convenience.

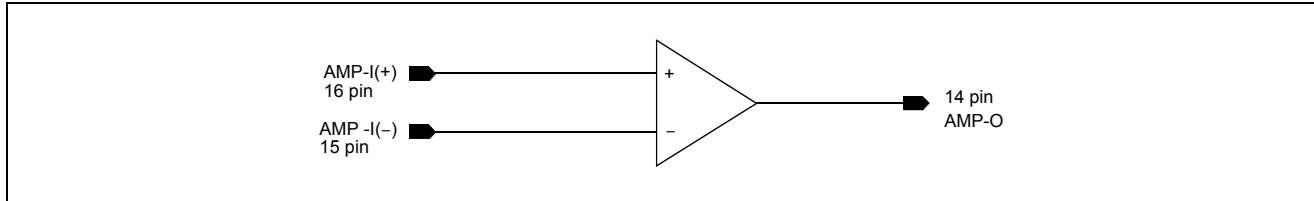

4. DRIVER

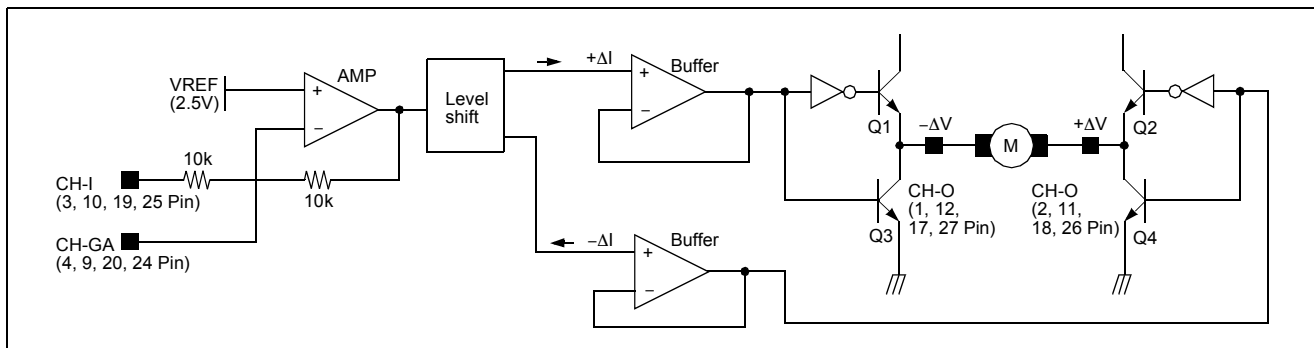

- The voltage, V_{REF} is the reference voltage given by the bias voltage of the pin #23.
- The input signal through the pin #3 is amplified by 10k/10k times and then fed to the level shift.
- The level shift produces the current due to the difference between the input signal and the arbitrary reference signal. The current produced as $+\Delta I$ and $-\Delta I$ is fed into the driver buffer.
- Driver buffer operates the power TR of the output stage according to the state of the input signal.
- The output stage is the BTL driver and the motor is rotating in forward direction by operating TR Q1 and TR Q4. On the other hand, if TR Q2 and TR Q3 is operating, the motor is rotating in reverse direction.
- When the input voltage through the pin #3 is below the V_{REF} , then the direction of the motor in forward direction.
- When the input voltage through the pin #3 is above the V_{REF} , then the direction of the motor in reverse direction.
- If it is desired to change the gain, then the pin #4 can be used.
- The gain (A_V) of the drive circuit is as follows.

$$A_V = 20 \log \left[\frac{4V_{IN}}{V_{IN}} \right] = 12(dB)$$

5. Connect a by-pass capacitor , 0.1 μ F between the supply voltage source .

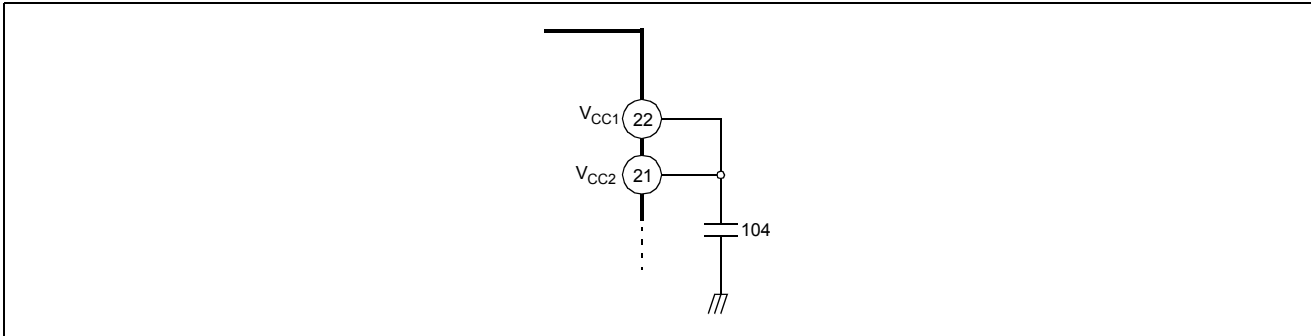

6. Radiation fin is connecting to the internal GND of the package.
Connect the fin to the external GND.

ELECTRICAL CHARACTERISTICS CURVES

1. V_{CC} vs. output current

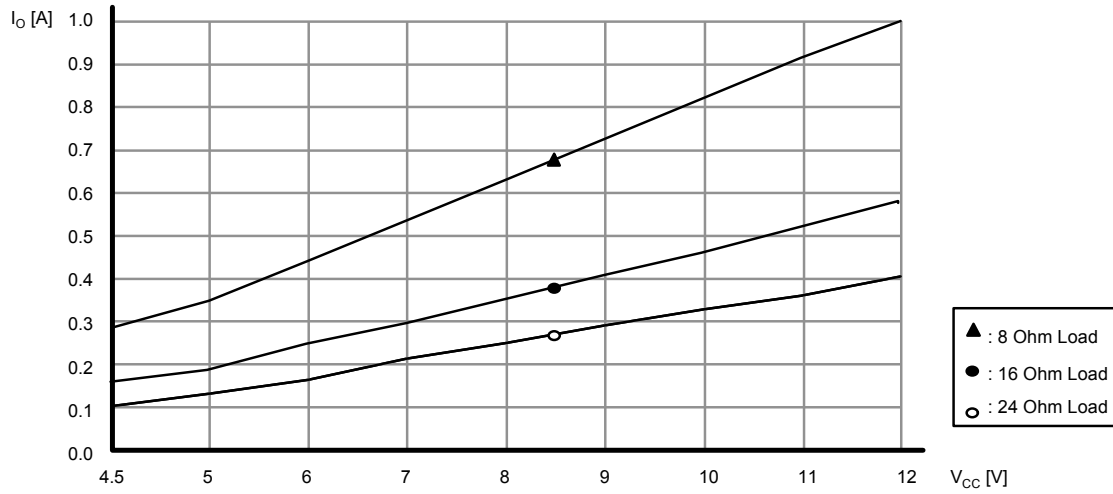

2. V_{CC} vs. V_{out}

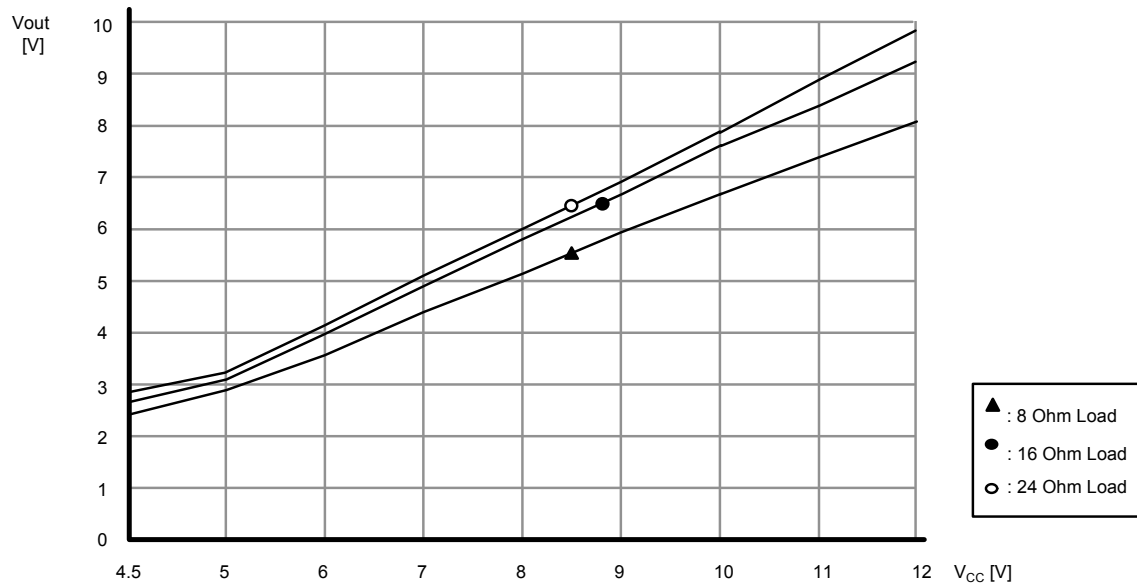

TEST CIRCUIT

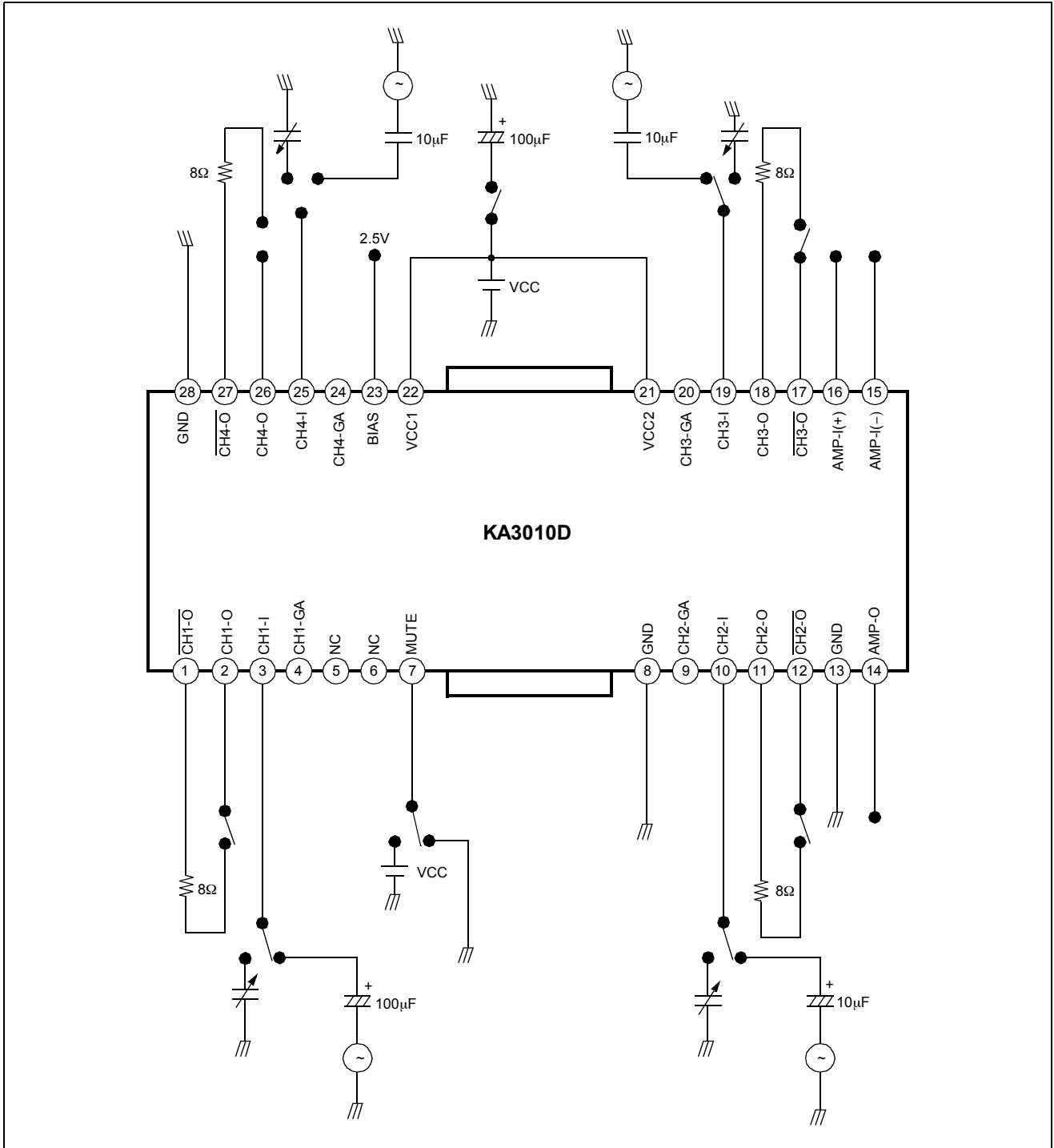

APPLICATION CIRCUIT

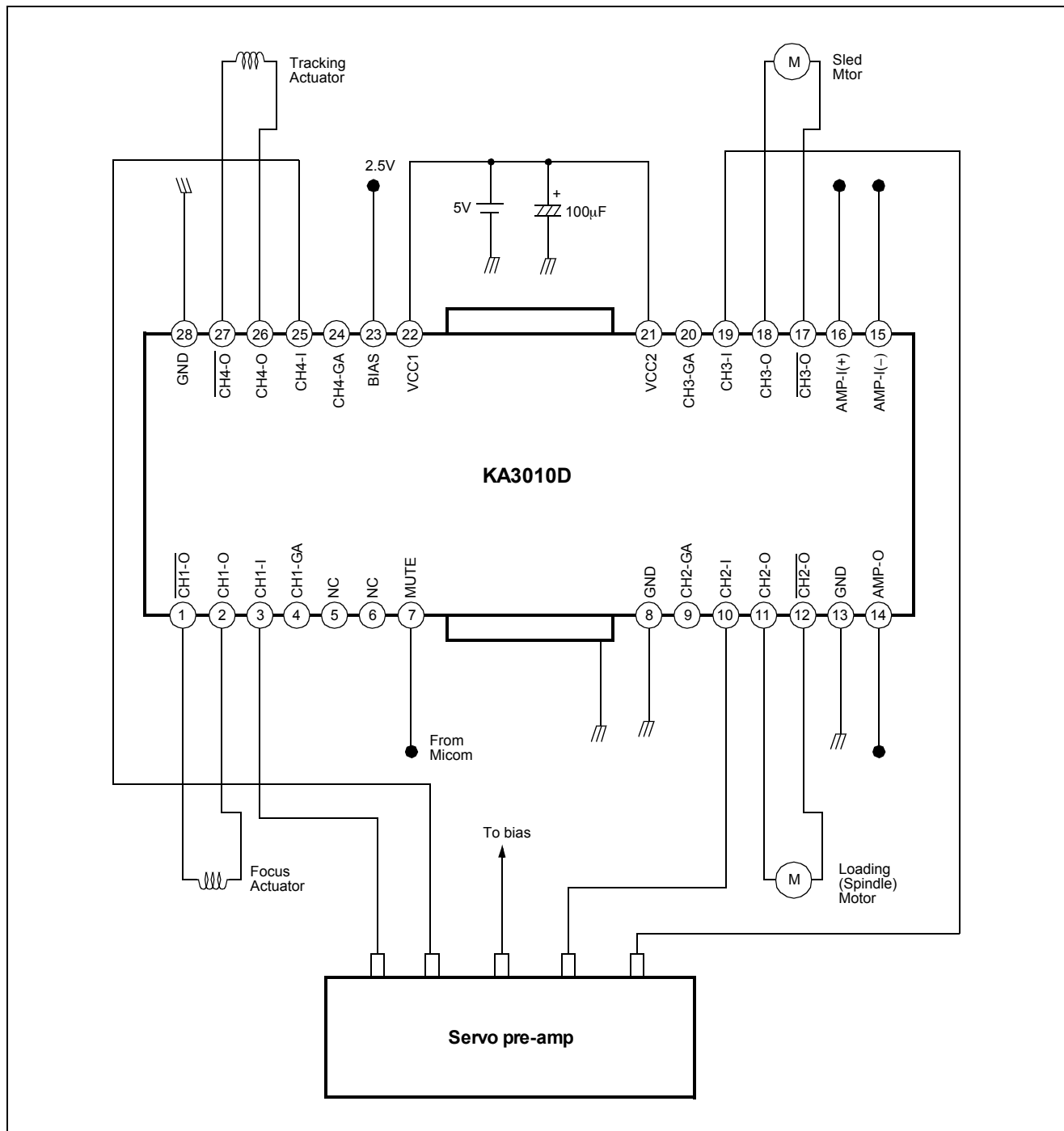

PACKAGE DIMENSION

28-SSOPH-375

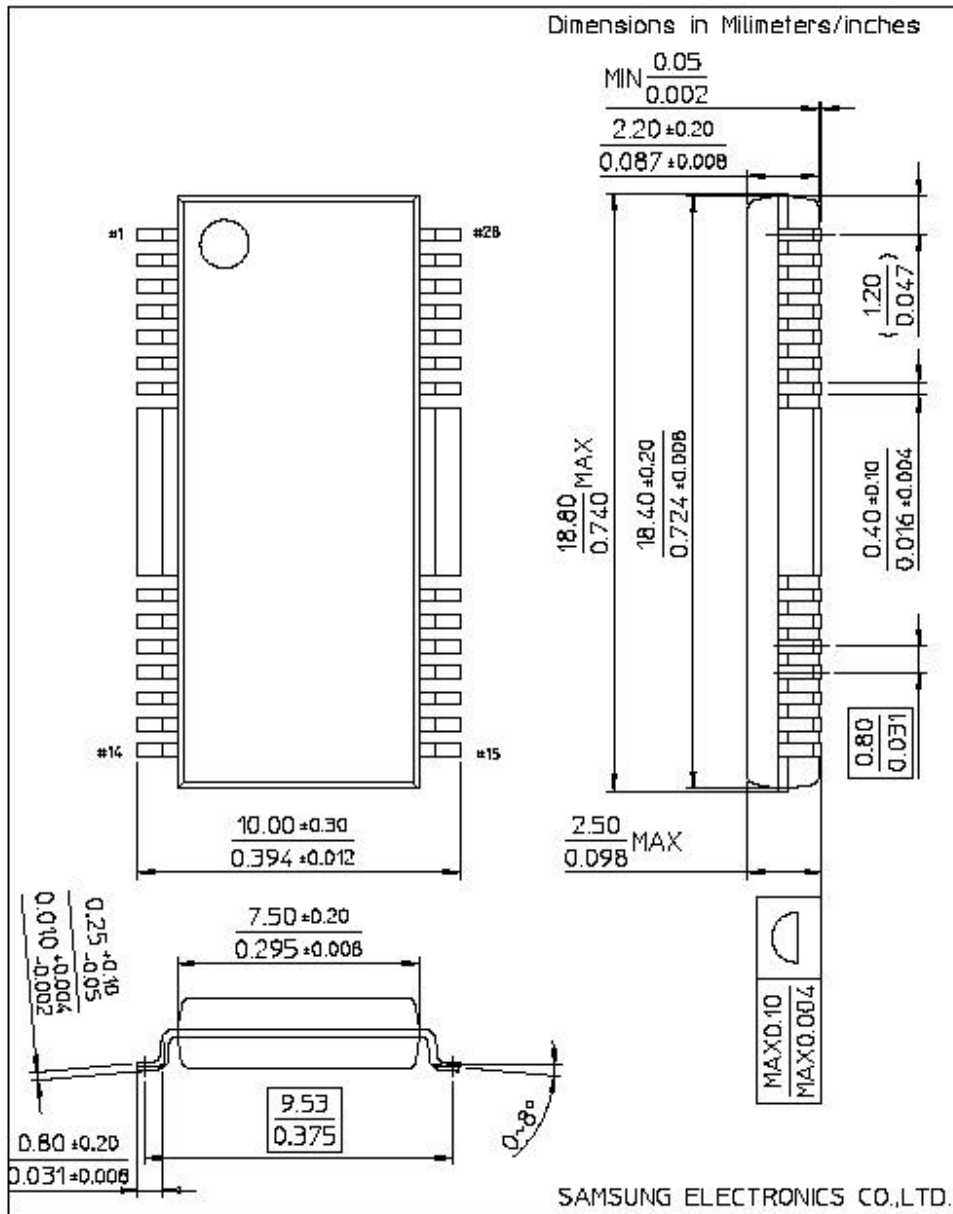

TRADEMARKS

The following are registered and unregistered trademarks Fairchild Semiconductor owns or is authorized to use and is not intended to be an exhaustive list of all such trademarks.

ACEx™	ISOPLANAR™
CoolFET™	MICROWIRE™
CROSSVOLT™	POP™
E ² CMOS™	PowerTrench™
FACT™	QS™
FACT Quiet Series™	Quiet Series™
FAST®	SuperSOT™-3
FASTr™	SuperSOT™-6
GTO™	SuperSOT™-8
HiSeC™	TinyLogic™

DISCLAIMER

FAIRCHILD SEMICONDUCTOR RESERVES THE RIGHT TO MAKE CHANGES WITHOUT FURTHER NOTICE TO ANY PRODUCTS HEREIN TO IMPROVE RELIABILITY, FUNCTION OR DESIGN. FAIRCHILD DOES NOT ASSUME ANY LIABILITY ARISING OUT OF THE APPLICATION OR USE OF ANY PRODUCT OR CIRCUIT DESCRIBED HEREIN; NEITHER DOES IT CONVEY ANY LICENSE UNDER ITS PATENT RIGHTS, NOR THE RIGHTS OF OTHERS.

LIFE SUPPORT POLICY

FAIRCHILD'S PRODUCTS ARE NOT AUTHORIZED FOR USE AS CRITICAL COMPONENTS IN LIFE SUPPORT DEVICES OR SYSTEMS WITHOUT THE EXPRESS WRITTEN APPROVAL OF FAIRCHILD SEMICONDUCTOR CORPORATION. As used herein:

1. Life support devices or systems are devices or systems which, (a) are intended for surgical implant into the body, or (b) support or sustain life, or (c) whose failure to perform when properly used in accordance with instructions for use provided in the labeling, can be reasonably expected to result in significant injury to the user.
2. A critical component is any component of a life support device or system whose failure to perform can be reasonably expected to cause the failure of the life support device or system, or to affect its safety or effectiveness.

PRODUCT STATUS DEFINITIONS

Definition of Terms

Datasheet Identification	Product Status	Definition
Advance Information	Formative or In Design	This datasheet contains the design specifications for product development. Specifications may change in any manner without notice.
Preliminary	First Production	This datasheet contains preliminary data, and supplementary data will be published at a later date. Fairchild Semiconductor reserves the right to make changes at any time without notice in order to improve design.
No Identification Needed	Full Production	This datasheet contains final specifications. Fairchild Semiconductor reserves the right to make changes at any time without notice in order to improve design.
Obsolete	Not In Production	This datasheet contains specifications on a product that has been discontinued by Fairchild semiconductor. The datasheet is printed for reference information only.