

FSD210

Fairchild Power Switch(FPS)

Features

- Single Chip 700V SenseFET Power Switch
- Precision Fixed Operating Frequency (134kHz)
- Consumes under 0.1W at 265VAC at no load with an Advanced Burst-Mode Operation
- Internal Start-up Switch and Soft Start
- UVLO with Hysteresis (6.7V/8.7V)
- Pulse by Pulse Current Limit
- Over Load Protection
- Internal Thermal Shutdown Function (Hysteresis)
- Secondary Side Regulation
- Auto-Restart Mode
- Frequency Modulation for EMI

Applications

- Charger & Adaptor for Mobile Phone, PDA & MP3
- Auxiliary Power for PC, C-TV & Monitor

Description

The FSD210 is specially designed for an off-line SMPS with minimal external components. The FSD210 is a monolithic high voltage power switching regulator that combines an LDMOS SenseFET with a voltage mode PWM control block. The integrated PWM controller features: A fixed oscillator with frequency modulation for reduced EMI. Under voltage lock out. Leading edge blanking(LEB). Optimized gate turn-on/turn-off driver. Thermal shut down protection. Temperature compensated precision current sources for loop compensation and fault protection circuitry. Compared to a discrete MOSFET and controller or RCC switching converter solution, an FSD210 can reduce total component count, design size, weight and at the same time increase efficiency, productivity, and system reliability. It is a basic platform well suited for cost effective design of flyback converters.

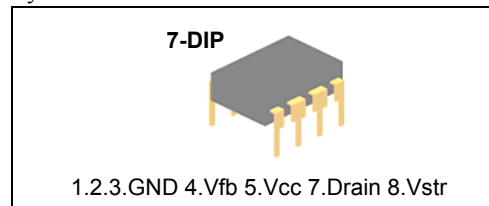

Internal Block Diagram

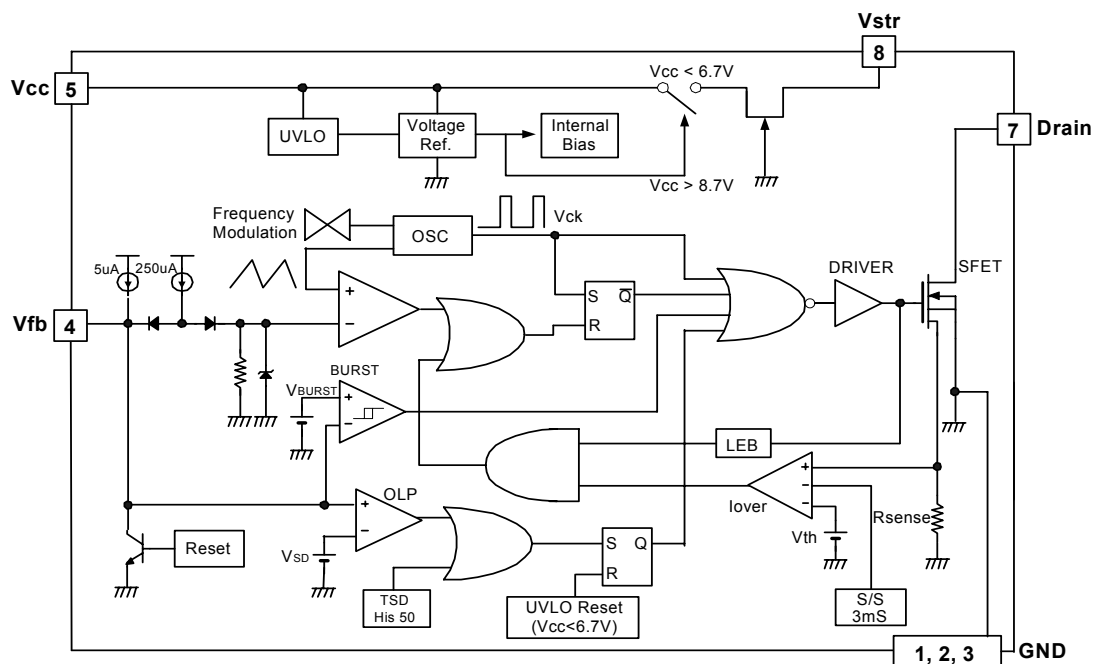

Rev.1.0.0

Absolute Maximum Ratings

(Ta=25°C unless otherwise specified)

Parameter	Symbol	Value	Unit
Maximum Vstr Pin Voltage	Vstr,max	700	V
Maximum Supply Voltage	VCC,MAX	20	V
Input Voltage Range	VFB	-0.3 to VSD	V
Operating Ambient Temperature	TA	-25 to +85	°C
Storage Temperature Range	TSTG	-55 to +150	°C

Pin Definitions

Pin Number	Pin Name	Pin Function Description
1, 2, 3	GND	These pins are the control ground and the SenseFET Source.
4	Vfb	This pin is the inverting input of the PWM comparator. It operates normally between 0.5V and 2.5V. It has a 0.25mA current source connected internally and a capacitor and opto coupler connected externally. A feedback voltage of 3V to 4V triggers overload protection (OLP). There is a time delay due to the 5uA current source, which prevents false triggering under transient conditions but still allows the protection mechanism to operate under true overload conditions.
5	Vcc	This is the positive supply voltage input. During start up, current is supplied to this pin from Pin 7 via an internal switch. When Vcc reaches the UVLO upper threshold (8.7V), the internal switch start-up switch (Vstr) opens and power is supplied from auxiliary transformer winding.
7	Drain	This pin is designed to directly drive the converter transformer and is capable of switching a maximum of 700V.
8	Vstr	This pin connects directly to the rectified AC line voltage source. At start up the internal switch supplies internal bias and charges an external capacitor that connects from the Vcc pin to ground. once this reaches 8.7V, the internal current source is disabled.

Electrical Characteristics

(Ta=25°C unless otherwise specified)

Parameter	Symbol	Condition	Min.	Typ.	Max.	Unit
SENSEFET SECTION						
Drain-Source Breakdown Voltage	BV _{dss}	V _{CC} = 0V, I _D = 100μA	700	-	-	V
Off-State Current	I _{dss}	V _{DS} = 560V	-	-	100	μA
On-State Resistance	R _{DS(ON)}	T _j = 25°C I _D = 25mA	-	28	32	Ω
Rise Time	T _R	V _{DS} = 325V, I _D = 50mA	-	100	-	nS
Fall Time	T _F	V _{DS} = 325V, I _D = 25mA	-	50	-	nS
CONTROL SECTION						
Output Frequency	F _{osc}	T _j = 25°C	126	134	142	kHz
			-	±4	-	
Feedback Source Current	I _{fb}	V _{fb} = 0V	0.22	0.25	0.28	mA
Maximum Duty Cycle	D _{max}	V _{fb} = 3.5V	60	64	68	%
Minimum Duty Cycle	D _{min}	V _{fb} = 0V	0	0	0	%
UVLO Threshold Voltage	V _{start}		8.0	8.7	9.4	V
	V _{stop}	After turn on	6.0	6.7	7.4	V
Internal Soft Start Time	T _{S/S}		-	3	-	mS
BURST MODE SECTION						
Burst Mode Voltage	V _{BURST}	Hysteresis	-	0.64	-	V
			-	60	-	mV
PROTECTION SECTION						
Drain to Source Peak Current Limit	I _{over}		0.26	0.30	0.34	A
Thermal Shutdown Temperature (T _j) ⁽¹⁾	T _{SD}	Hysteresis	125	145	-	°C
			-	50	-	°C
Shutdown Feedback Voltage	V _{SD}	-	3.5	4.0	4.5	V
Feedback Shutdown Delay Current	I _{delay}	V _{fb} = 4.0V	3	5	7	μA
TOTAL DEVICE SECTION						
Operating Supply Current	I _{OP}	V _{CC} = 11V	-	700	-	μA
Start Up Current	I _{start}	V _{CC} = 0V	-	670	840	μA

Note:

1. These parameters, although guaranteed, are not 100% tested in production

Typical Performance Characteristics

(These characteristic graphs are normalized at Ta=25°C)

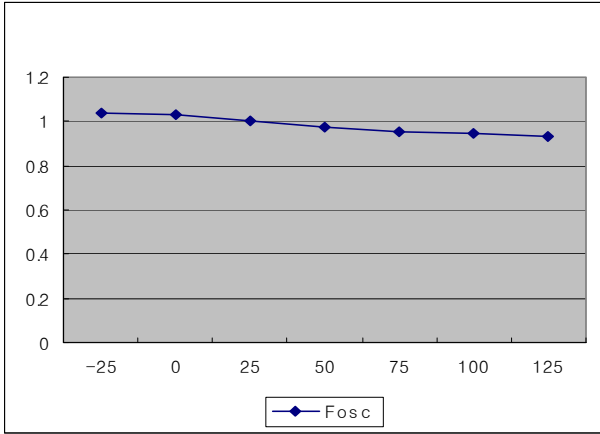

Figure 1. Frequency vs. Temp

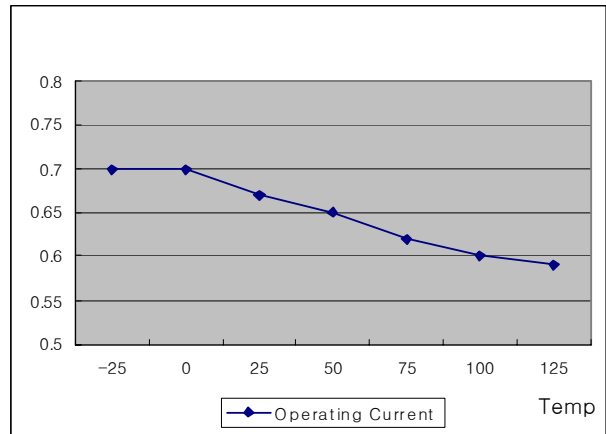

Figure 2. Operating Current vs. Temp

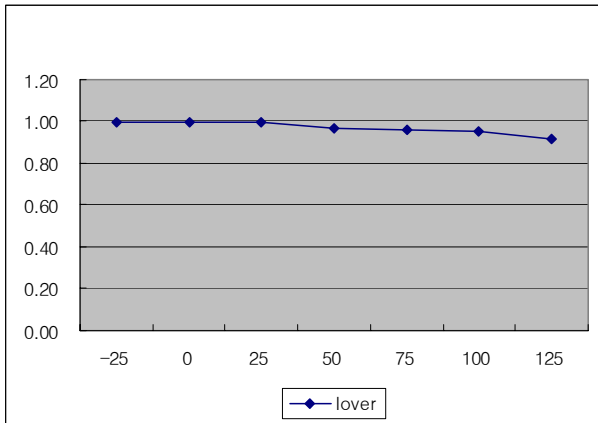

Figure 3. Peak Current Limit vs. Temp

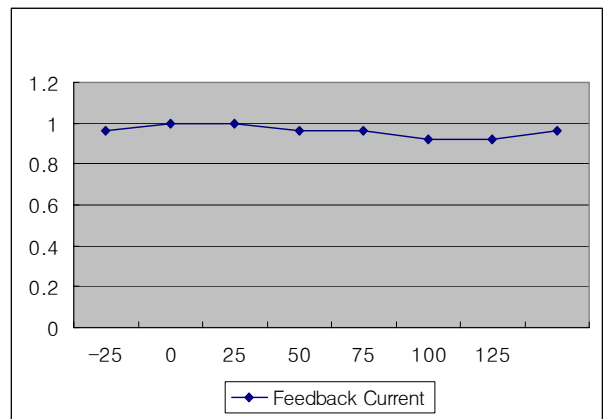

Figure 4. Feedback Source Current vs. Temp

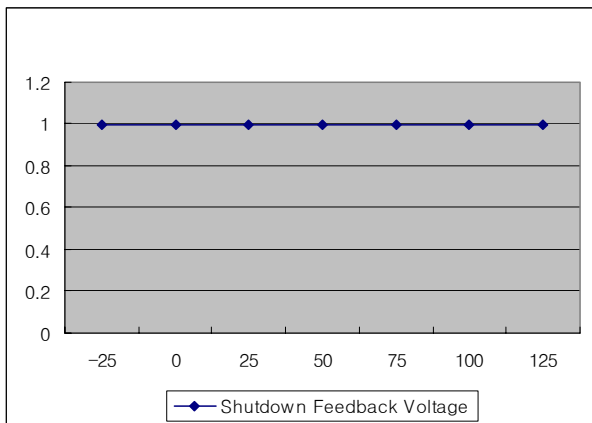

Figure 5. Shutdown Feedback Voltage vs. Temp

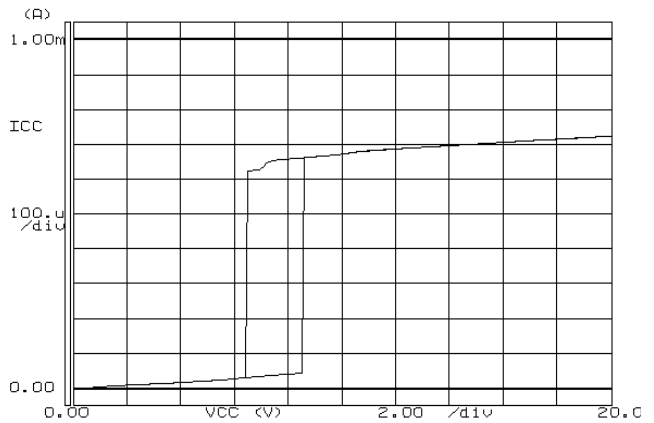

Figure 6. Operating Current vs. Vcc Voltage

Typical Performance Characteristics (Continued)

(These characteristic graphs are normalized at $T_a=25^\circ\text{C}$)

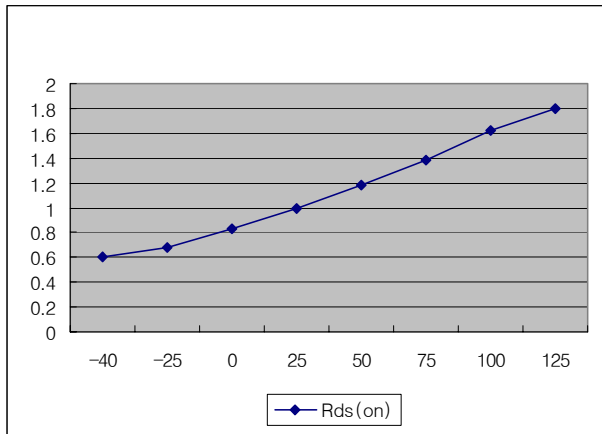

Figure 7. On State Resistance vs. Temp

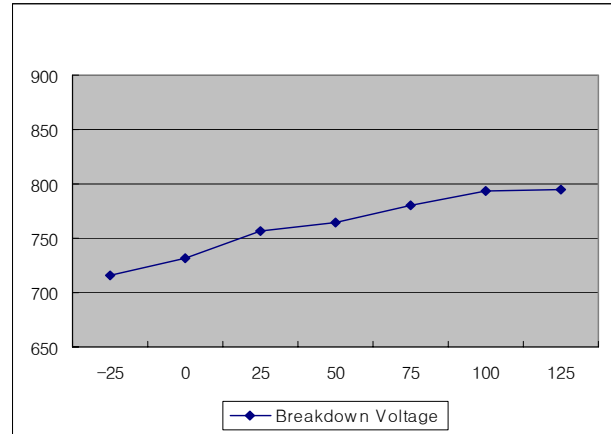
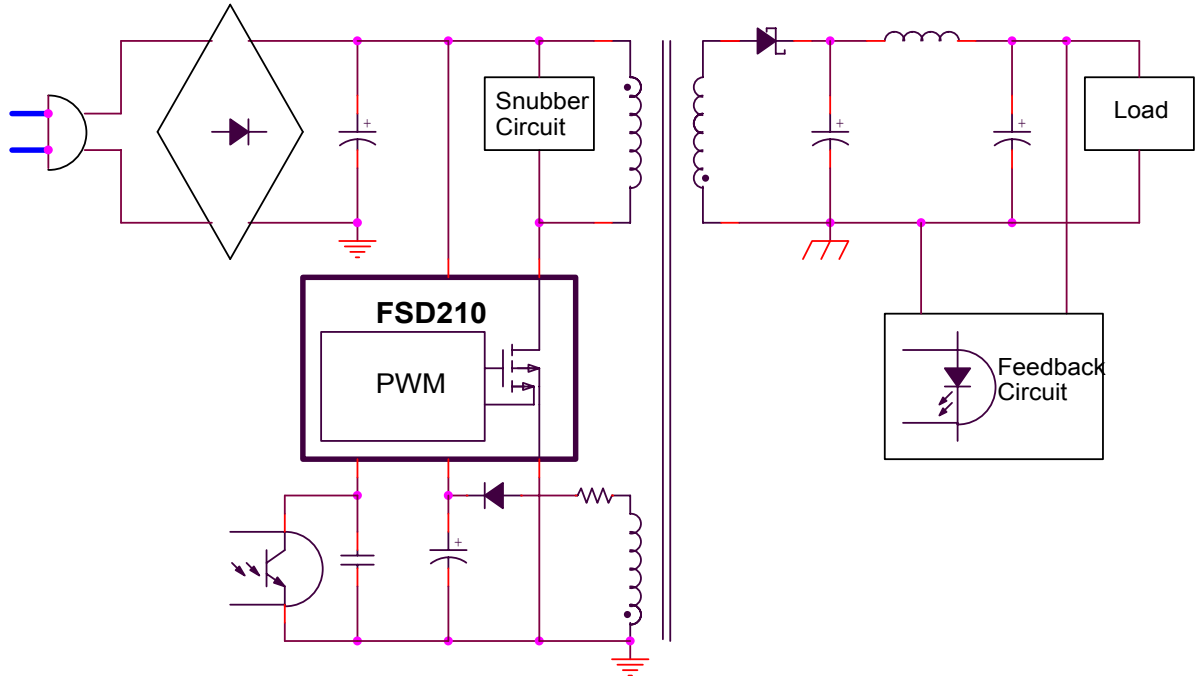

Figure 8. Breakdown Voltage vs. Temp

Typical Circuit



Product Information

Basic system topology of FSD200/210 is the same as the original FSDH565/0165 devices. The FSD210 devices require a bias winding, whereas the FSD200 devices do not. Other features of the two types of devices are almost the same and are listed below.

Product Parameter	With Bias Winding		Without Bias Winding	
	FSD210	FSD211	FSD200	FSD201
Breakdown voltage (min)	700V BODMOS	700V BODMOS	700V BODMOS	700V BODMOS
On-state Resistance (max)	32ohm	18ohm	32ohm	18ohm
Current Limit (typ.lower)	0.3A	0.48A	0.3A	0.48A
Switching Frequency	134kHz	134kHz	134kHz	134kHz
Frequency Modulation	±4kHz	±4kHz	±4kHz	±4kHz
Operating Current (max)	770uA	770uA	770uA	770uA
Burst function	o	o	o	o
Thermal Shutdown(yp.)	145°C(Hys 50°C)	145°C(Hys 50°C)	145°C(Hys 50°C)	145°C(Hys 50°C)
Package Type	7DIP/7SMD	7DIP/7SMD	7DIP/7SMD	7DIP/7SMD
Output Power	85~265VAC	4W	6W	4W

Figure 1. Line-up Table

Functional Description

1. Startup : At startup, an internal high voltage current source supplies the internal bias and charges the external Vcc capacitor as shown in Figure 1. In the case of the FSD210, when Vcc reaches 8.7V the device starts switching and the internal high voltage current source is disabled. The device continues to switch provided that Vcc does not drop below 6.7V. After startup the bias is supplied from the auxiliary transformer winding. In the case of FSD200, Vcc is continuously supplied from the external high voltage source and Vcc is regulated to 7V by an internal high voltage regulator (HV Reg). The internal startup switch is not disabled and an auxiliary winding is not required. Figure 2.

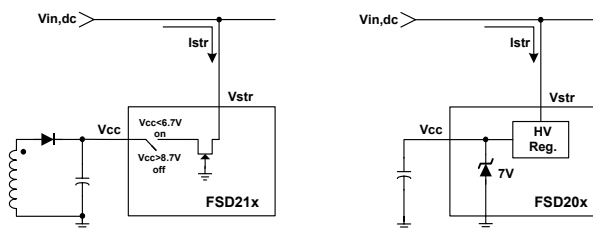

Figure 2. Internal startup circuit

2. Feedback Control : The FSD200/210 are voltage mode devices as shown in Figure 3. Usually, an optocoupler and KA431 type voltage reference are used to implement the feedback network. The feedback voltage is compared with an internally generated sawtooth waveform. This directly controls the duty cycle. When

the KA431 reference pin voltage exceeds the internal reference voltage of 2.5V, the optocoupler LED current increase pulling down the feedback voltage and reducing the duty cycle. This will happen when the input voltage increases or the output load decreases.

3. Leading edge blanking (LEB) : When the MOSFET turns on, there will usually be a large current spike through the MOSFET. This is caused by primary side capacitance and secondary side rectifier reverse recovery. This could cause premature termination of the switching pulse if it exceeded the over-current threshold. Therefore, the FPS uses a leading edge blanking (LEB) circuit. This circuit inhibits the pver-current comparator for a short time after the MOSFET is turned on.

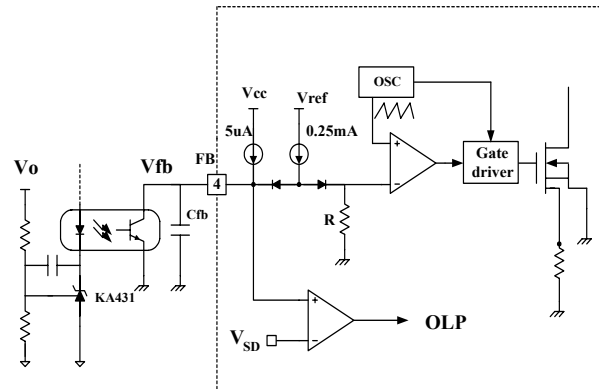

Figure 3. PWM and feedback circuit

4. Protection Circuit : The FSD200/210 has 2 self protection functions: over-load protection (OLP) and thermal shutdown (TSD). Because these protection circuits are fully integrated into the IC with no external components, system reliability is improved without cost increase. If either of these functions are triggered, the FPS starts an auto-restart cycle. Once the fault condition occurs, switching is terminated and the MOSFET remains off. This cause Vcc to fall. When Vcc reaches the UVLO stop voltage (6.7:FSD210, 6V:FSD200), the protection is reset and the internal high voltage current source charges the Vcc capacitor. When Vcc reaches the UVLO start voltage (8.7V:FSD210, 7V:FSD200), the device attempts to resume normal operation. If the fault condition is no longer present start up will be successful. If it is still present the cycle is repeated. This is shown in Figure 4.

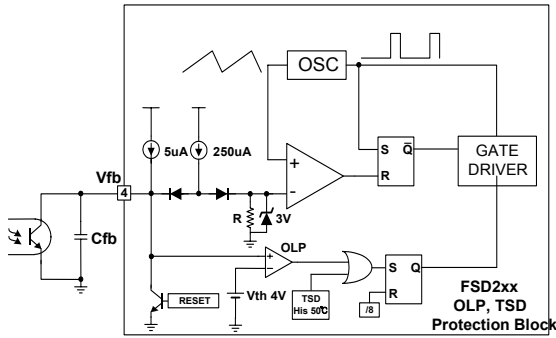

Figure 4. Protection block

4.1 Over Load Protection (OLP) : Overload is a load current that exceeds a pre-set level due to an abnormal situation. If this occurs, the protection circuit should be triggered to protect the SMPS. It is possible that a short term load transient can occur under normal operation. If this occurs the system should not shut down. In order to avoid false shut-downs, the over load protection circuit is designed to trigger after a delay. Therefore the device can discriminate between transient overloads and true fault conditions. The device is pulse-by-pulse current limited and therefore, for a given input voltage, the maximum input power is limited. If the load tries to draw more than this, the output voltage will drop below its set value. This reduces the opto-coupler LED current which in turn will reduce the photo-transistor current. Therefore, the 250uA current source will charge the feedback pin capacitor, Cfb, and the feedback voltage, Vfb, will increase. The input to the feedback comparator is clamped at around 3V. Therefore, once Vfb reaches 3V, the device is switching at maximum power. At this point the 250uA current source is blocked and the 5uA source continues to charge Cfb. Once Vfb reaches 4V, switching stops. Therefore the shutdown delay time is set by the time required to charge Cfb from 3V to 4V with 5uA as shown in Fig. 5.

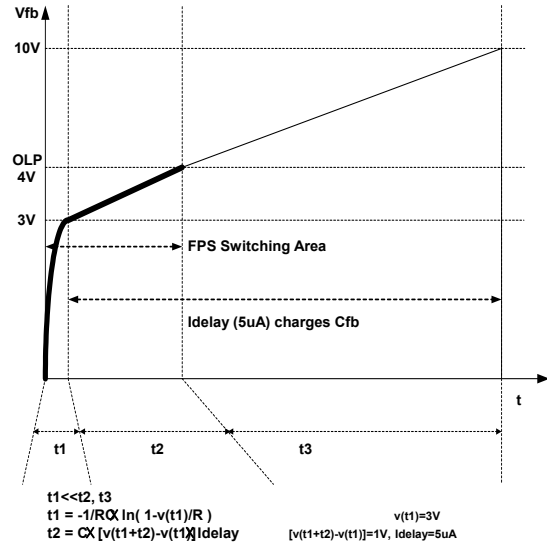
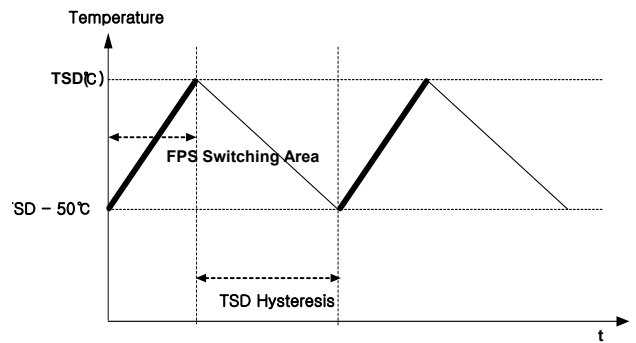
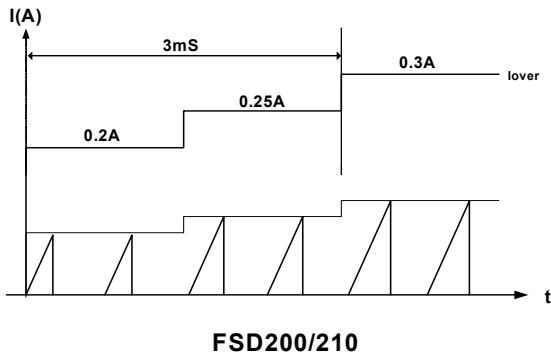

Figure 5. Over load protection delay

4.2 Thermal Shutdown (TSD) : The SenseFET and the control IC are assembled in one package. This makes it easy for the control IC to detect the temperature of the SenseFET. When the temperature exceeds approximately 150°C, thermal shutdown is activated. Thermal shutdown has a Hysteresis of 50°C and so the temperature must drop to 100°C before the device attempts to restart.



5. Soft Start : FSD200/210 has an internal soft start circuit that increases the feedback voltage together with the MOSFET current slowly at start up. The soft start time is 3msec in FSD200/210.



6. Burst operation : In order to minimize the power dissipation in standby mode, the FSD200/210 implements burst mode.

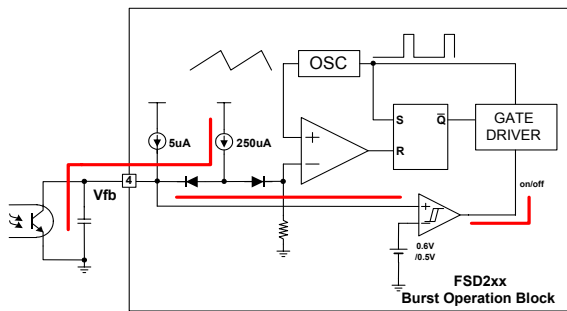

Figure 6. Circuit for burst operation

As the load decreases, the feedback voltage decreases. The device automatically enters burst mode when the feedback voltage drops below 0.5V. At this point switching stops and the output voltages start to drop. This causes the feedback voltage to rise. Once it passes 0.6V switching starts again. The feedback voltage falls and the process repeats. Burst mode operation alternately enables and disables switching of the power MOSFET to reduce the switching loss in the standby mode.

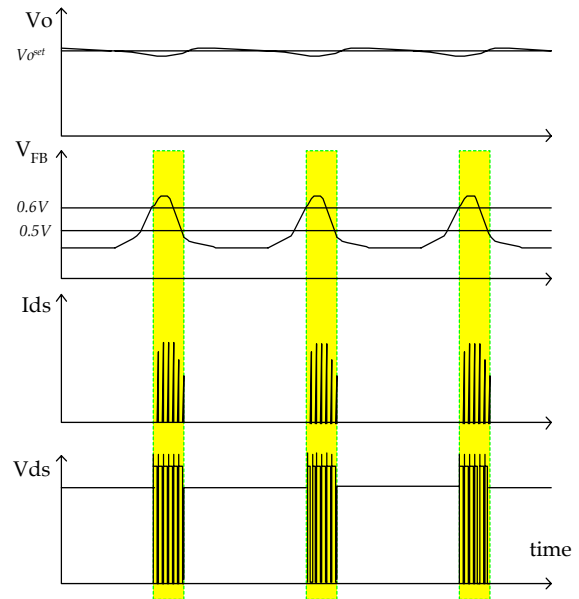
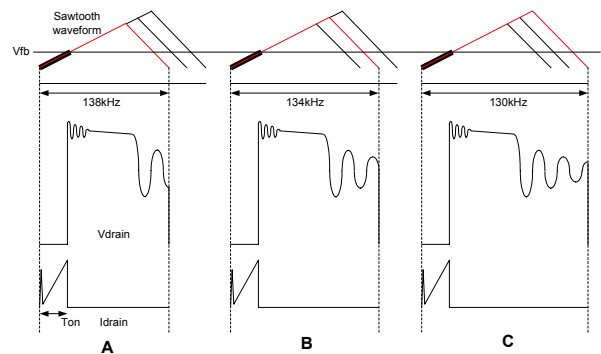
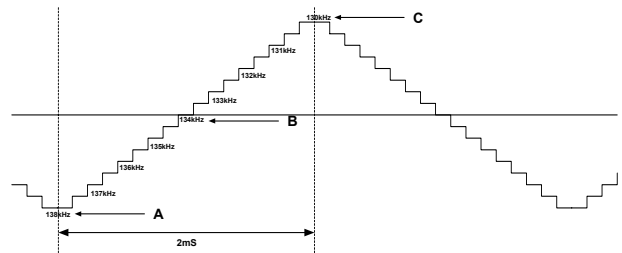

Figure 7. Burst mode operation

7. Frequency Modulation



Typical application circuit

1. Cellular Phone Charger Example Circuit

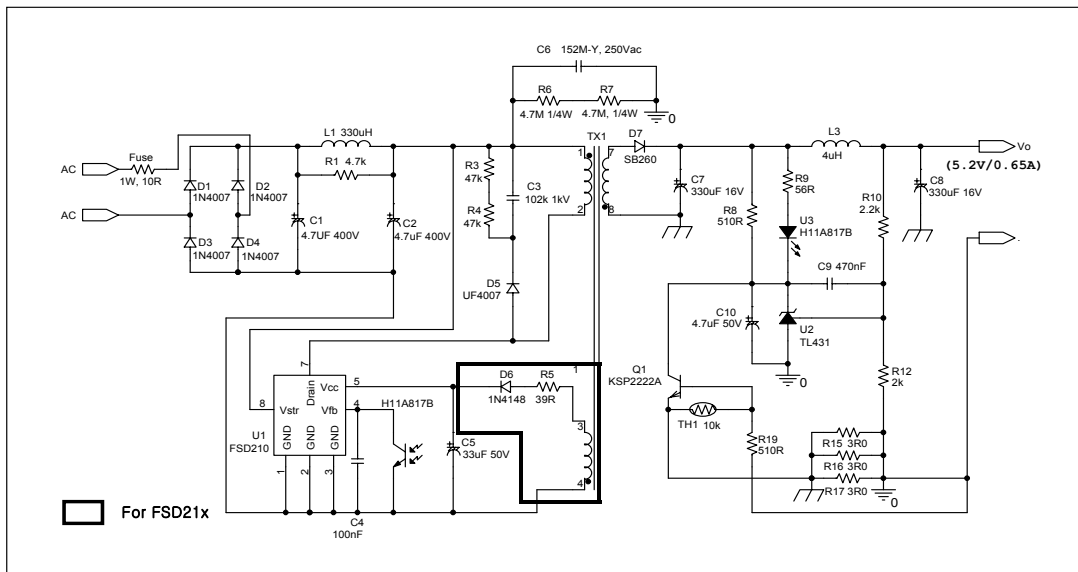

Reference	Part #	Quantity	Description	Requirement/Comment
D1,D2,D3,D4	1N4007	4	1A/1000V Junction Rectifier	DO41 Type
D5	UF4007	1	1A/1000V Ultra Fast Diode	DO41 Type
D6	1N4148	1	10mA/100V Junction Diode	DO-213 Type
D7	SB260	1	2A/60V Schottky Diode	DO-41 Type
Q1	KSP2222A	1	Ic=600mA, Vce=30V	TO-92 Type
U1	FSD210 (FSD200)	1	0.5A/700V	lower=0.3A, Fairchildsemi
U2	KA431AZ	1	Vref=2.495V(Typ.)	TO-92 Type, LM431
U3	H11A817A	1	CTR 80~160%	-

1. Schematic diagram(Top view)

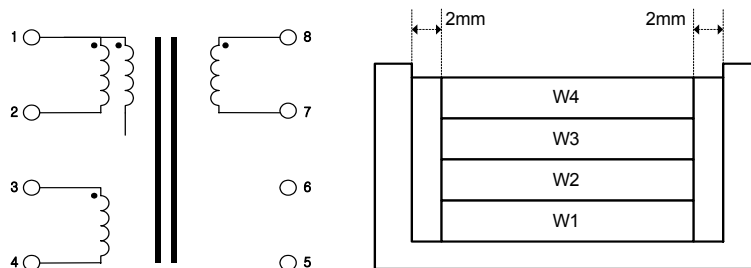

2. Core & Bobbin

CORE : EE1616
BOBBIN : EE1616(H)

3. Winding specification

No.	Pin (S → F)	Wire	Turns	Winding Method
W 1	1 → 2	0.16Φ X 1	99 Ts	SOLENOID WINDING
INSULATION : POLYESTER TAPE t=0.025mm / 10mm, 2Ts				
W 2	4 → 3	0.16Φ X 1	18 Ts	CENTER SOLENOID WINDING
INSULATION : POLYESTER TAPE t=0.025mm / 10mm, 2Ts				
W 3	1 → open	0.16Φ X 1	50 Ts	SOLENOID WINDING
INSULATION : POLYESTER TAPE t=0.025mm / 10mm, 3Ts				
W 4	8 → 7	0.40Φ X 1	9 Ts	SOLENOID WINDING
INSULATION : POLYESTER TAPE t=0.025mm / 10mm, 3Ts				

4. Electrical characteristic

ITEM	TERMINAL	SPECIFICATION	REMARKS
INDUCTANCE	1 - 2	1.6mH	1kHz, 1V
LEAKAGE L	1 - 2	50uH	3,4,7,8 short 100kHz, 1V

Typical application circuit

2. Buck Convertor

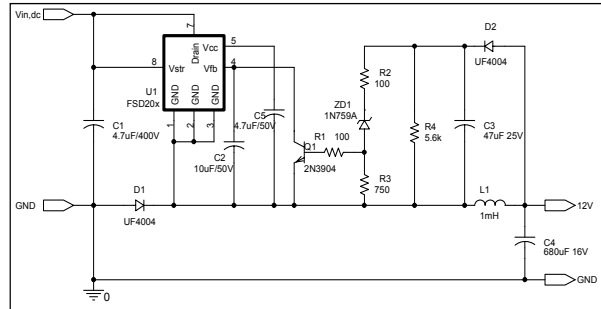
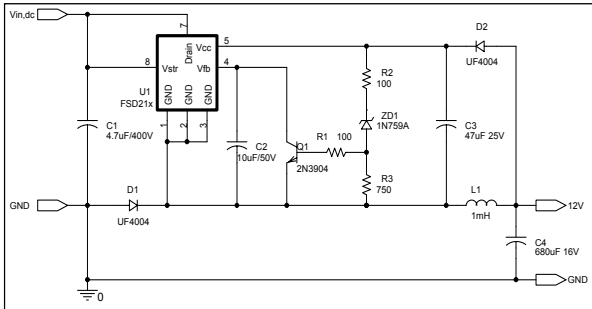

Reference	Part #	Quantity	Description	Requirement/Comment
D1,D2	UF4007	2	1A/1000V Ultra Fast Diode	DO41 Type
Q1	2N3904	1	Ic=200mA, Vce=40V	TO-92 Type
ZD1	1N759A	1	12V 0.5W	DO-35 Type
U1	FSD210 (FSD200)	1	0.5A/700V	I _{over} =0.3A, Fairchild

Package Dimensions

7-DIP

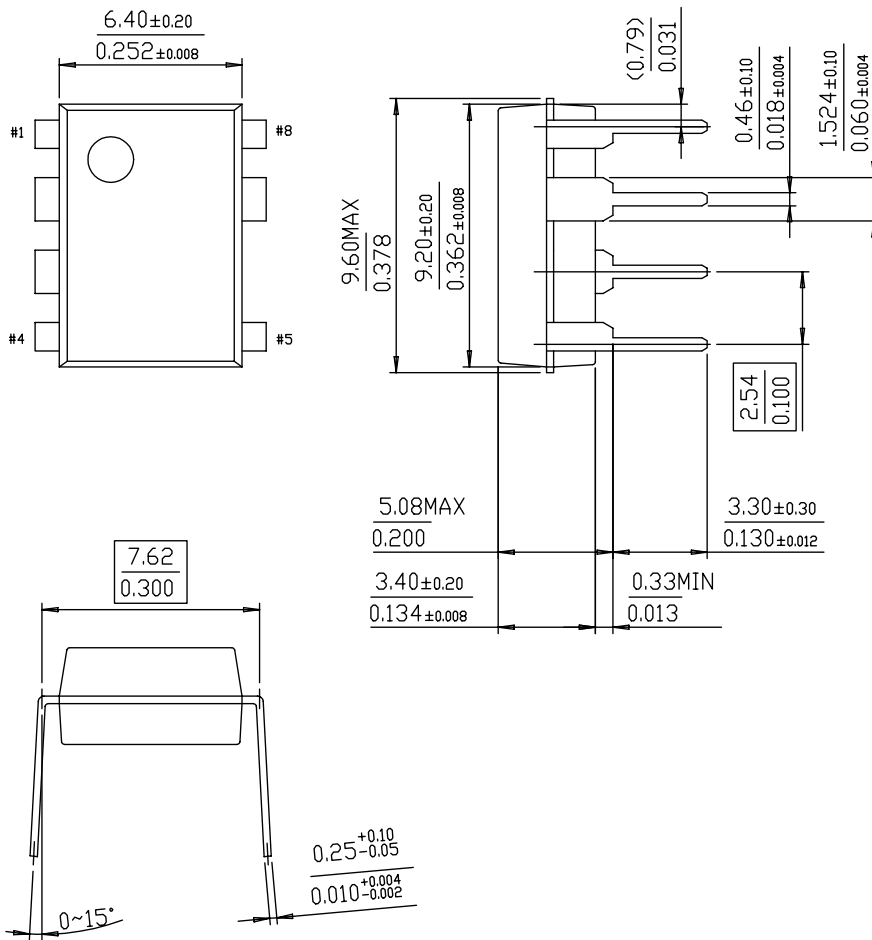

Ordering Information

Product Number	Package	Rating	Topr (°C)
FSD210	7DIP	700V, 0.5A	-25°C to +85°C

DISCLAIMER

FAIRCHILD SEMICONDUCTOR RESERVES THE RIGHT TO MAKE CHANGES WITHOUT FURTHER NOTICE TO ANY PRODUCTS HEREIN TO IMPROVE RELIABILITY, FUNCTION OR DESIGN. FAIRCHILD DOES NOT ASSUME ANY LIABILITY ARISING OUT OF THE APPLICATION OR USE OF ANY PRODUCT OR CIRCUIT DESCRIBED HEREIN; NEITHER DOES IT CONVEY ANY LICENSE UNDER ITS PATENT RIGHTS, NOR THE RIGHTS OF OTHERS.

LIFE SUPPORT POLICY

FAIRCHILD'S PRODUCTS ARE NOT AUTHORIZED FOR USE AS CRITICAL COMPONENTS IN LIFE SUPPORT DEVICES OR SYSTEMS WITHOUT THE EXPRESS WRITTEN APPROVAL OF THE PRESIDENT OF FAIRCHILD SEMICONDUCTOR CORPORATION. As used herein:

1. Life support devices or systems are devices or systems which, (a) are intended for surgical implant into the body, or (b) support or sustain life, and (c) whose failure to perform when properly used in accordance with instructions for use provided in the labeling, can be reasonably expected to result in a significant injury of the user.
2. A critical component in any component of a life support device or system whose failure to perform can be reasonably expected to cause the failure of the life support device or system, or to affect its safety or effectiveness.