

AN7112

0.5W Audio Power Amplifier

■ Description

The AN7112 is a monolithic integrated circuit designed for 0.5W audio power amplifier.

■ Features

- Wide operating supply voltage range: $V_{CC} = 4V \sim 14V$
- Low quiescent current: $I_{CQ} = 15mA$
(at $V_{CC} = 6V, R_L = 8\Omega$)

■ Pin

Pin No.	Pin Name
1	Phase Compensation
2	Input
3	N.F.B.
4	Phase Compensation
5	GND
6	Output
7	Vcc
8	Bootstrap
9	Ripple Filter

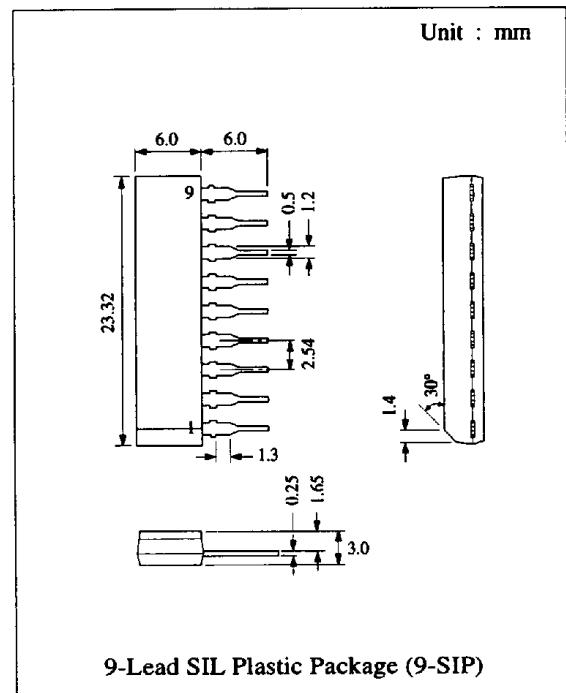

■ Block Diagram

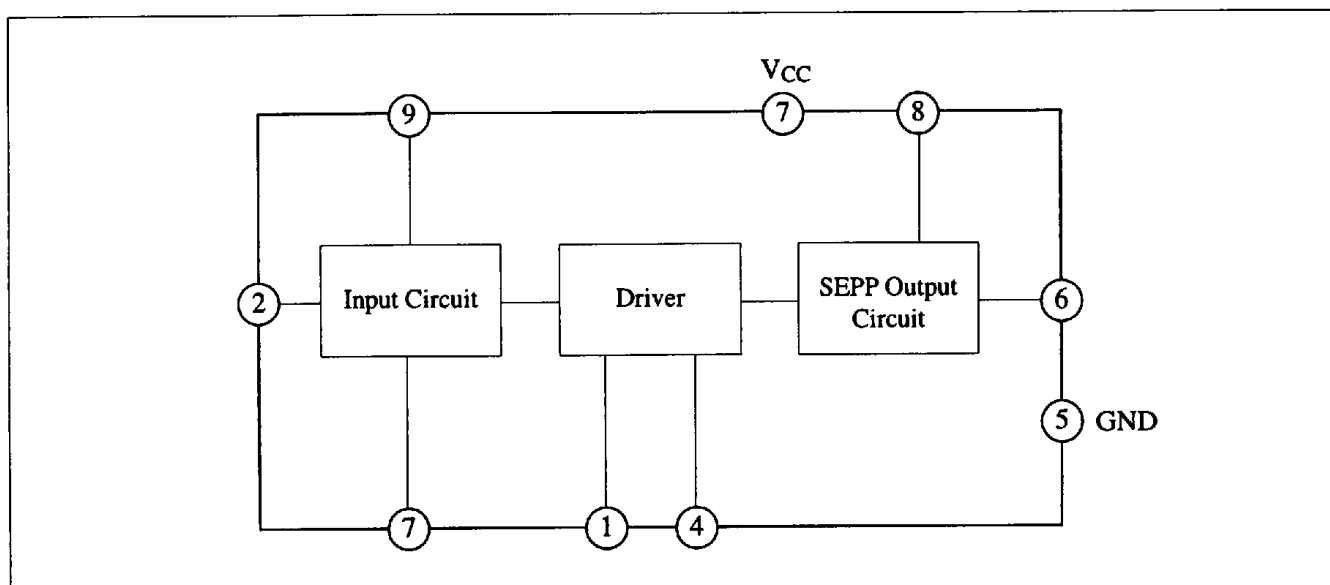

■ Absolute Maximum Ratings (Ta=25°C)

Item	Symbol	Rating	Unit
Supply Voltage	V _{CC}	14	V
Supply Current	I _{CC(peak)}	500	mA
Power Dissipation	P _D	1	W
Operating Ambient Temperature	T _{opr}	-25 ~ +75	°C
Storage Temperature	T _{stg}	-55 ~ +150	°C

Operating Supply Voltage Range: V_{CC} = 4.0V ~ 14.0V

■ Electrical Characteristics (V_{CC}=6V, R_L=8Ω, f=1kHz, Ta=25°C)

Item	Symbol	Condition	min.	typ.	max.	Unit
Quiescent Current	I _{CQ}	V _{CC} = 4V, V _{in} = 0mV	5			mA
		V _{CC} = 6V, V _{in} = 0mA		15	20	mA
		V _{CC} = 9V, V _{in} = 0mV		17	23	mA
Open Circuit Voltage Gain	G _{VO}	P _O = 100mW, R _{NF} = 0Ω	65	71		dB
Closed Circuit Voltage Gain	G _{VC}	P _O = 100mW, R _{NF} = 47Ω	47	50	52	dB
Maximum Output Power	P _O	V _{CC} = 6V, THD = 10%	0.45	0.5		W
		V _{CC} = 9V, R _L = 16Ω, THD = 10%		0.7		W
Total Harmonic Distortion	THD	P _O = 100mW		0.3	1.0	%
Input Resistance	R _{in}			15		kΩ
Output Noise Voltage	V _{no}	BW = 50Hz ~ 20kHz, R _g = 10kΩ		0.4	1.0	mV

Test Circuit

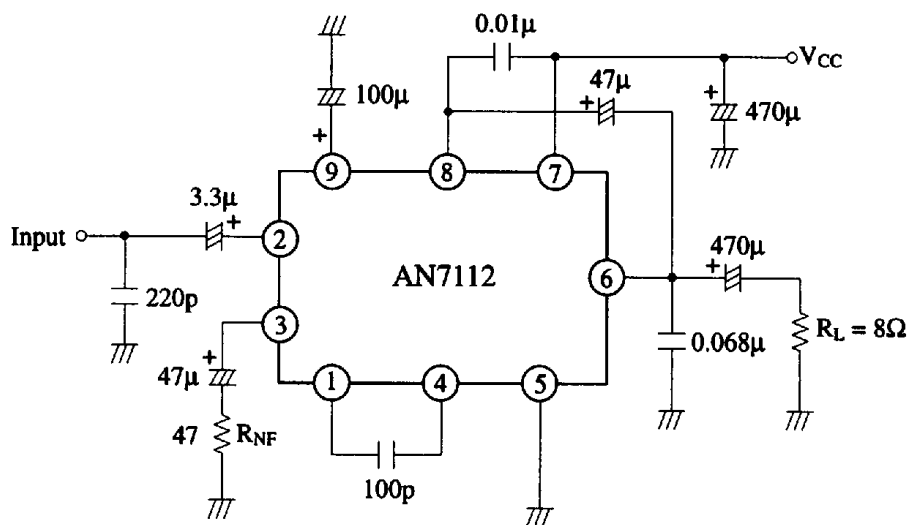

■ Application Circuit

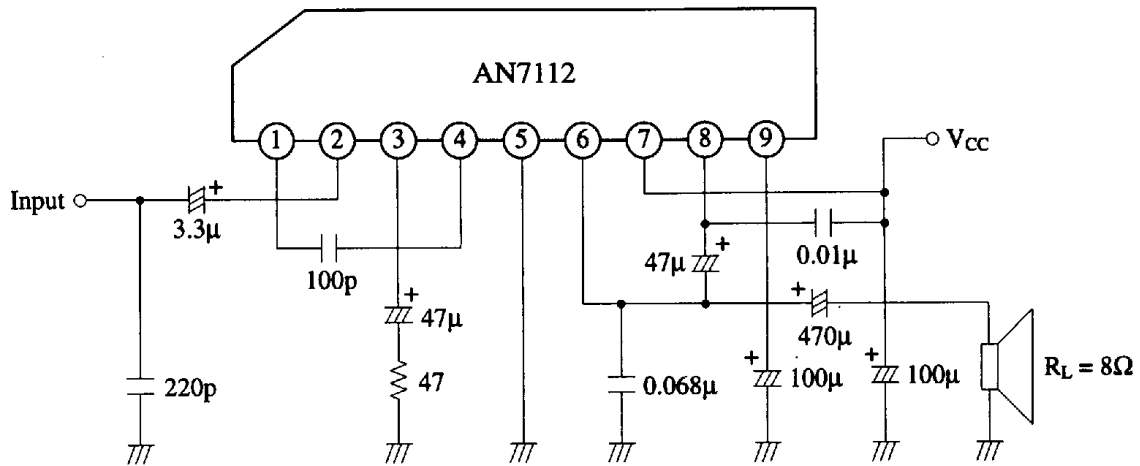

■ Characteristics Curve

