

DATA SHEET

SAA5290

One page Economy Teletext/TV
microcontroller

Preliminary specification
File under Integrated Circuits, IC02

February 1995

Philips Semiconductors



PHILIPS

One page Economy Teletext/TV microcontroller

SAA5290

FEATURES

General

- Complete one page teletext decoder and TV microcontroller in a single 52-pin package
- Eastern European, Western European and Turkish language variants covered in one device
- Double size, double width and double height character capability for On-Screen Display (OSD)
- Enhanced display features including meshing and shadowing
- Separate display and acquisition timing for increased flexibility
- Minimum peripheral component count
- 525 line and 625 line display synchronization
- Standby mode through power-down of teletext and analog hardware.

Microcontroller

- 16 kbytes masked ROM (16 kbytes EEPROM variant for product development)
- 256 bytes of on-chip RAM
- Six 6-bit Pulse Width Modulators (PWM) and one 14-bit precision PWM
- 4-bit Digital-to-Analog Converter (DAC) and comparator with a 3-input multiplexer allowing implementation of 3 Analog-to-Digital Converters (ADC) in software
- 2 high current (10 mA) open-drain outputs
- Interrupt logic 0 triggered on rising and falling edges, providing pulse-width measurement for remote control decoding
- Master and slave bit-level I²C-bus hardware.



DESCRIPTION

The SAA5290 is a single-chip one page teletext decoder and television control microcontroller. The device will decode 625-line based World System Teletext transmissions and provides television control functions and On-Screen Display (OSD) functions.

The teletext decoder hardware is a derivative of the SAA5254 (IVT1.1X), and the TV control functionality provided by an on-chip industrial standard 80C51 microcontroller. A single-page static RAM is included on-board providing a complete one page teletext decoder and OSD memory.

The SAA5290 is available as a mask-programmed ROM version. An EEPROM version is also available for product development. Both versions are available in an SDIP52 package.

ORDERING INFORMATION

TYPE NUMBER	MEMORY	PACKAGE		
		NAME	DESCRIPTION	VERSION
SAA5290ZP/nnn ⁽¹⁾	ROM	SDIP52	plastic shrink dual in-line package; 52 leads (600 mil)	SOT247-1
SAA5290ZP/NVI ⁽²⁾	EEPROM	SDIP52	plastic shrink dual in-line package; 52 leads (600 mil)	SOT247-1

Notes

1. nnn is a three-digit number referencing the microcontroller program ROM mask.
2. I is a digit number referring to the language variant of the SAA5290ZP/NV.

One page Economy Teletext/TV microcontroller

SAA5290

QUICK REFERENCE DATA

SYMBOL	PARAMETER	MIN.	TYP.	MAX.	UNIT
V _{DD}	supply voltage	4.5	5.0	5.5	V
I _{DDM}	microcontroller supply current	-	25	40	mA
I _{DDA}	analog supply current	-	35	50	mA
I _{DDT}	teletext supply current	-	20	30	mA
f _{xtal}	crystal frequency	-	12	-	MHz
T _{amb}	operating ambient temperature	-20	-	+70	°C

BLOCK DIAGRAM

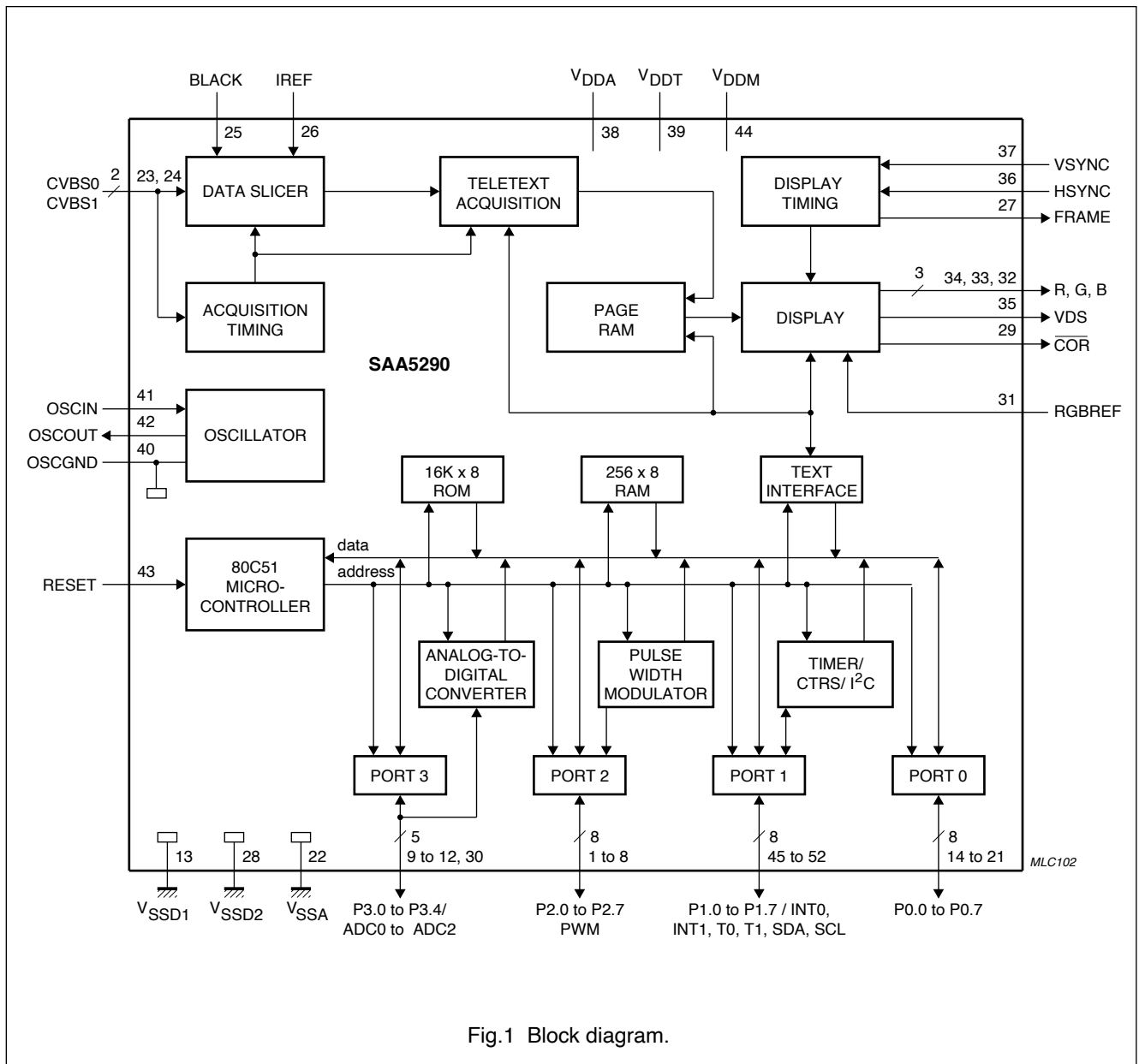

Fig.1 Block diagram.

One page Economy Teletext/TV microcontroller

SAA5290

PINNING

SYMBOL	PIN	DESCRIPTION
P2.0/TPWM	1	PORT 2: 8-bit open-drain bidirectional port with alternative functions. P2.0/TPWM is the output for the 14-bit high precision PWM. P2.1/PWM0 to P2.6/PWM5 are the outputs for the 6-bit PWMs 0 to 5.
P2.1/PWM0	2	
P2.2/PWM1	3	
P2.3/PWM2	4	
P2.4/PWM3	5	
P2.5/PWM4	6	
P2.6/PWM5	7	
P2.7	8	
P3.0/ADC0	9	PORT 3: 5-bit open-drain bidirectional port with alternative functions. P3.0/ADC0 to P3.2/ADC2 are the inputs for the software ADC facility.
P3.1/ADC1	10	
P3.2/ADC2	11	
P3.3	12	
P3.4	30	
V _{SSD1}	13	digital ground 1 for teletext and microcontroller circuits.
P0.0	14	PORT 0: 8-bit open-drain bidirectional port. P0.5 and P0.6 have 10 mA current sinking capability at 0.5 V for direct drive of LEDs.
P0.1	15	
P0.2	16	
P0.3	17	
P0.4	18	
P0.5	19	
P0.6	20	
P0.7	21	
V _{SSA}	22	analog ground.
CVBS0	23	Composite video input. A positive-going 1 V (peak-to-peak) input is required, connected via a 100 nF capacitor.
CVBS1	24	
BLACK	25	Video black level storage input. This pin should be connected to V _{SSA} via a 100 nF capacitor.
IREF	26	Reference current input for analog circuits, connected to V _{SSA} via a 27 kΩ resistor.
FRAME	27	De-interlace output synchronized with the VSYNC pulse to produce a non-interlaced display by adjustment of the vertical deflection currents.
V _{SSD2}	28	Digital ground 2.
COR	29	Open-drain, active LOW output which allows selective contrast reduction of the TV picture to enhance a mixed mode display.
RGBREF	31	DC input voltage to define the output HIGH level on the RGB pins.
B	32	Dot rate character output of the BLUE colour information.
G	33	Dot rate character output of the GREEN colour information.
R	34	Dot rate character output of the RED colour information.
VDS	35	Video/data switch push-pull output for dot rate fast blanking.
HSYNC	36	Horizontal sync dedicated input for a TTL-level version of the horizontal sync pulse. The polarity of this pulse is programmable by register bit TXT1.H POLARITY.

One page Economy Teletext/TV microcontroller

SAA5290

SYMBOL	PIN	DESCRIPTION
VSYNC	37	Vertical sync dedicated input for a TTL-level version of the vertical sync pulse. The polarity of this pulse is programmable by register bit TXT1.V POLARITY.
V _{DDA}	38	+5 V analog power supply.
V _{DDT}	39	+5 V teletext power supply.
OSCGND	40	Crystal oscillator ground.
OSCIN	41	12 MHz crystal oscillator input.
OSCOU	42	12 MHz crystal oscillator output.
RESET	43	If the reset input is HIGH for 2 machine cycles (24 oscillator periods) while the oscillator is running, the SAA5290 is reset. This pin should be connected to V _{DDM} via a 2.2 μ F capacitor.
V _{DDM}	44	+5 V microcontroller power supply.
P1.0/INT1	45	PORT 1: 8-bit open-drain bidirectional port with alternative functions. P1.0/INT1 is external interrupt 1 which can be triggered on the rising and falling edge of the pulse. P1.1/T0 is the counter/timer 0. P1.2/INT0 is external interrupt 0. P1.3/T1 is the counter/timer 1. P1.6/SCL is the serial clock input for I ² C-bus. P1.7/SDA is the serial data port for the I ² C-bus.
P1.1/T0	46	
P1.2/INT0	47	
P1.3/T1	48	
P1.6/SCL	49	
P1.7/SDA	50	
P1.4	51	
P1.5	52	

One page Economy Teletext/TV
microcontroller

SAA5290

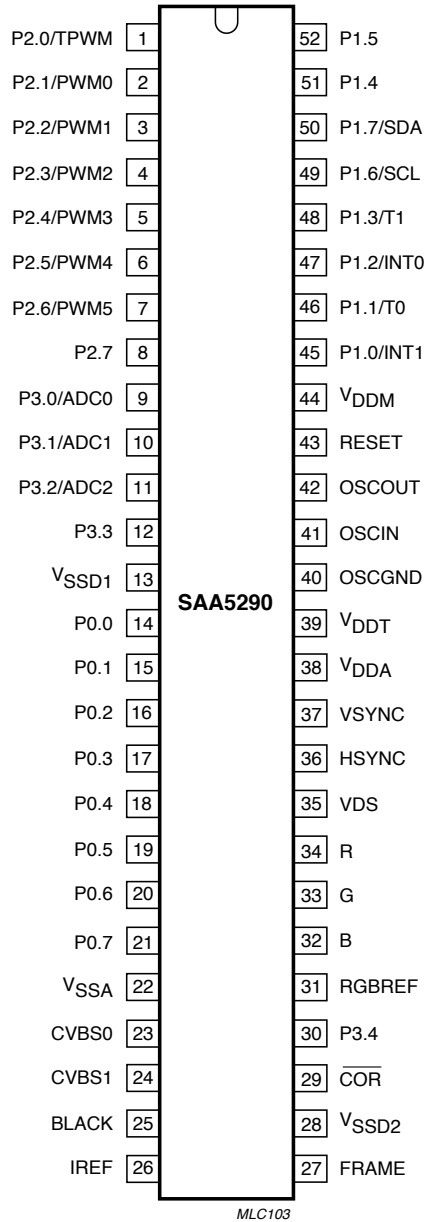

Fig.2 Pin configuration.

One page Economy Teletext/TV microcontroller

SAA5290

QUALITY AND RELIABILITY

This device will meet Philips Semiconductors General Quality Specification for Business group "Consumer Integrated Circuits SNW-FQ-611-Part E" (see "Quality Reference Handbook", order number 9398 510 63011). The principal requirements are shown in Tables 1 to 4.

Group A

Table 1 Acceptance tests per lot

TEST	REQUIREMENTS ⁽¹⁾
Mechanical	cumulative target: <80 ppm
Electrical	cumulative target: <80 ppm

Group B

Table 2 Processability tests (by package family)

TEST	REQUIREMENTS ⁽¹⁾
Solderability	<7% LTPD
Mechanical	<15% LTPD
Solder heat resistance	<15% LTPD

Group C

Table 3 Reliability tests (by process family)

TEST	CONDITIONS	REQUIREMENTS ⁽¹⁾
Operational life	168 hours at $T_j = 150\text{ }^\circ\text{C}$	<1500 FPM; equivalent to <100 FITS at $T_j = 70\text{ }^\circ\text{C}$
Humidity life	temperature, humidity, bias 1000 hours, $85\text{ }^\circ\text{C}$, 85% RH (or equivalent test)	<2000 FPM
Temperature cycling performance	$T_{\text{stg}(\text{min})}$ to $T_{\text{stg}(\text{max})}$	<2000 FPM

Table 4 Reliability tests (by device type)

TEST	CONDITIONS	REQUIREMENTS ⁽¹⁾
ESD and latch-up	ESD Human body model 2000 V, 100 pF, 1.5 k Ω	<15% LTPD
	ESD Machine model 200 V, 200 pF, 0 Ω	<15% LTPD
	latch-up 100 mA, $1.5 \times V_{\text{DD}}$ (absolute maximum)	<15% LTPD

Notes to Tables 1 to 4

- ppm = fraction of defective devices, in parts per million.
LTPD = Lot Tolerance Percent Defective.
FPM = fraction of devices failing at test condition, in Failures Per Million.
FITS = Failures In Time Standard.

One page Economy Teletext/TV microcontroller

SAA5290

LIMITING VALUES

In accordance with Absolute Maximum Rating System (IEC 134).

SYMBOL	PARAMETER	CONDITIONS	MIN.	MAX.	UNIT
V_{DD}	supply voltage (all supplies)		-0.3	+6.5	V
V_I	input voltage (any input)	note 1	-0.3	$V_{DD} + 0.5$	V
V_O	output voltage (any output)	note 1	-0.3	$V_{DD} + 0.5$	V
I_O	output current (each output)		-	±10	mA
I_{IOK}	DC input or output diode current		-	±20	mA
ΔV_{SS}	difference between V_{SSD} , V_{SSA} and OSCGND		-	±0.1	V
ΔV_{DD}	difference between V_{DDM} , V_{DDT} and V_{DDA}	note 2	-	±0.1	V
T_{amb}	operating ambient temperature		-20	+70	°C
T_{stg}	storage temperature		-55	+125	°C

Notes

1. This maximum value has an absolute maximum of 6.5 V independent of V_{DD} .
2. Except in standby mode.

CHARACTERISTICS

$V_{DD} = 5\text{ V} \pm 10\%$; $V_{SS} = 0\text{ V}$; $T_{amb} = -20\text{ to }+70\text{ °C}$; unless otherwise specified.

SYMBOL	PARAMETER	CONDITIONS	MIN.	TYP.	MAX.	UNIT
Supplies						
V_{DD}	supply voltage (V_{DD} to V_{SS})		4.5	5.0	5.5	V
I_{DDM}	microcontroller supply current		-	25	40	mA
I_{DDA}	analog supply current		-	35	50	mA
I_{DDT}	teletext supply current		-	20	30	mA
Digital inputs						
RESET						
V_{IL}	LOW level input voltage		-0.3	-	$0.2V_{DD} - 0.1$	V
V_{IH}	HIGH level input voltage		$0.7V_{DD}$	-	$V_{DD} + 0.3$	V
I_{LI}	input leakage current	$V_I = 0\text{ to }V_{DD}$	-10	-	+10	µA
C_I	input capacitance		-	-	4	pF
HSYNC AND VSYNC						
V_{thf}	switching threshold falling		$0.2V_{DD}$	-	-	V
V_{thr}	switching threshold rising		-	-	$0.8V_{DD}$	V
V_{HYS}	hysteresis voltage		-	$0.33V_{DD}$	-	V
C_I	input capacitance		-	-	4	pF

One page Economy Teletext/TV microcontroller

SAA5290

SYMBOL	PARAMETER	CONDITIONS	MIN.	TYP.	MAX.	UNIT
Digital outputs						
R, G AND B (note 1)						
V _{OL}	LOW level output voltage	I _{OL} = 2 mA	0	–	0.2	V
V _{OH}	HIGH level output voltage	I _{OH} = –2 mA	V _{RGBREF} – 0.3	V _{RGBREF}	V _{RGBREF} + 0.4	V
Z _O	output impedance		–	–	150	Ω
C _L	load capacitance		–	–	50	pF
I _O	DC output current		–	–	–4	mA
t _r	output rise time	between 10% and 90%; C _L = 50 pF	–	–	20	ns
t _f	output fall time	between 90% and 10%; C _L = 50 pF	–	–	20	ns
COR (OPEN-DRAIN OUTPUT)						
V _{OH}	HIGH level pull-up output voltage		–	–	V _{DD}	V
V _{OL}	LOW level output voltage	I _{OL} = 2 mA	0	–	0.5	V
I _{OL}	LOW level output current		–	–	2	mA
C _L	load capacitance		–	–	25	pF
VDS						
V _{OL}	LOW level output voltage	I _{OL} = 1.6 mA	0	–	0.2	V
V _{OH}	HIGH level output voltage	I _{OH} = –1.6 mA	V _{DD} – 0.3	–	V _{DD} + 0.4	V
C _L	load capacitance		–	–	50	pF
t _r	output rise time	between 10% and 90%; C _L = 50 pF	–	–	20	ns
t _f	output fall time	between 90% and 10%; C _L = 50 pF	–	–	20	ns
R, G, B AND VDS						
t _{skew}	skew delay between any two pins		–	–	20	ns
FRAME						
V _{OH}	HIGH level output voltage	I _{OL} = 8 mA	0	–	0.5	V
V _{OL}	LOW level output voltage	I _{OL} = –8 mA	V _{DD} – 0.5	–	V _{DD}	V
I _{OL}	LOW level output current		–8	–	+8	mA
C _L	load capacitance		–	–	100	pF

One page Economy Teletext/TV microcontroller

SAA5290

SYMBOL	PARAMETER	CONDITIONS	MIN.	TYP.	MAX.	UNIT
Digital input/outputs						
P0.0 TO P0.4, P0.7, P1.0 TO P1.5, P2.0 TO P2.7 AND P3.0 TO P3.5						
V _{IL}	LOW level input voltage		-0.3	-	0.2V _{DD} - 0.1	V
V _{IH}	HIGH level input voltage		0.2V _{DD} + 0.9	-	V _{DD} + 0.3	V
C _I	input capacitance		-	-	4	pF
V _{OL}	LOW level output voltage	I _{OL} = 3.2 mA	0	-	0.45	V
C _L	load capacitance		-	-	50	pF
P0.5 AND P0.6						
V _{IL}	LOW level input voltage		-0.3	-	0.2V _{DD} - 0.1	V
V _{IH}	HIGH level input voltage		0.2V _{DD} + 0.9	-	V _{DD} + 0.3	V
C _I	input capacitance		-	-	4	pF
V _{OL}	LOW level output voltage	I _{OL} = 10 mA	0	-	0.45	V
C _L	load capacitance		-	-	50	pF
P1.6 AND P1.7						
V _{IL}	LOW level input voltage		-0.3	-	+1.5	V
V _{IH}	HIGH level input voltage		3.0	-	V _{DD} + 0.3	V
C _I	input capacitance		-	-	5	pF
V _{OL}	LOW level output voltage	I _{OL} = 3 mA	0	-	0.5	V
C _L	load capacitance		-	-	400	pF
t _f	output fall time	between 3 and 1 V	-	-	200	ns
Analog inputs						
CVBS0 AND CVBS1						
V _{sync}	sync voltage amplitude		0.1	0.3	0.6	V
V _{vid(p-p)}	video input voltage amplitude (peak-to-peak value)		0.7	1.0	1.4	V
Z _{source}	source impedance		-	-	250	Ω
V _{IH}	HIGH level input voltage		3.0	-	V _{DD} + 0.3	V
Z _I	input impedance		2.5	5.0	-	kΩ
C _I	input capacitance		-	-	10	pF
IREF						
R _{gnd}	resistor to ground		-	27	-	kΩ
RGBREF (note 1)						
V _I	input voltage		-0.3	-	V _{DD}	V
I _I	DC input current		-	-	12	mA

One page Economy Teletext/TV microcontroller

SAA5290

SYMBOL	PARAMETER	CONDITIONS	MIN.	TYP.	MAX.	UNIT
ADC0, ADC1 AND ADC2						
V _{IL}	LOW level input voltage		-0.3	-	V _{DD}	V
Analog input/output						
BLACK						
C _{black}	storage capacitor to ground		-	100	-	nF
V _{black}	black level voltage for nominal sync amplitude		1.8	2.15	2.5	V
I _{LI}	input leakage current		-10	-	+10	μA
Crystal oscillator						
OSCIN						
V _{IL}	LOW level input voltage		-0.3	-	0.2V _{DD} - 0.1	V
V _{IH}	HIGH level input voltage		0.7V _{DD}	-	V _{DD} + 0.3	V
C _I	input capacitance		-	-	10	pF
OSCOU						
f _{osc}	crystal oscillator frequency		-	12	-	MHz
C _O	output capacitance		-	-	10	pF
CRYSTAL SPECIFICATION (note 2)						
f _{xtal}	nominal frequency		-	12	-	MHz
C _L	load capacitance		-	32	-	pF
C1	series capacitance	T _{amb} = 25 °C	-	18.5	-	fF
C0	parallel capacitance	T _{amb} = 25 °C	-	4.9	-	pF
R _r	resonance resistance	T _{amb} = 25 °C	-	35	-	Ω
T _{xtal}	temperature range		-20	+25	+70	°C
X _j	adjustment tolerance	T _{amb} = 25 °C	-	-	±50 × 10 ⁻⁶	
X _d	drift		-	-	±30 × 10 ⁻⁶	

Notes

1. All RGB current is sourced from the RGBREF pin. The maximum effective series resistance between RGBREF and the R, G and B pins is 150 Ω.
2. Crystal order number 4322 143 05561.

One page Economy Teletext/TV microcontroller

SAA5290

Table 5 Characteristics for the I²C-bus interface

SYMBOL	PARAMETER	INPUT	OUTPUT	I ² C-BUS SPECIFICATION
SCL timing				
t _{HD;STA}	START condition hold time	≥4.0 μs	note 1	≥4.0 μs
t _{LOW}	SCL LOW time	≥4.7 μs	note 1	≥4.7 μs
t _{HIGH}	SCL HIGH time	≥4.0 μs	≥4.0 μs; note 2	≥4.0 μs
t _{rC}	SCL rise time	≤1.0 μs	note 3	≤1.0 μs
t _{fC}	SCL fall time	≤0.3 μs	≤0.3 μs; note 4	≤0.3 μs
SDA timing				
t _{SU;DAT1}	data set-up time	≥250 ns	note 1	≥250 ns
t _{HD;DAT}	data hold time	≥0 ns	note 1	≥0 ns
t _{SU;STA}	repeated START set-up time	≥4.7 μs	note 1	≥4.7 μs
t _{SU;STO}	STOP condition set-up time	≥4.0 μs	note 1	≥4.0 μs
t _{BUF}	bus free time	≥4.7 μs	note 1	≥4.7 μs
t _{rD}	SDA rise time	≤1.0 μs	note 3	≤1.0 μs
t _{fD}	SDA fall time	≤0.3 μs	≤0.3 μs; note 4	≤0.3 μs

Notes

1. This parameter is determined by the user software. It must comply with the I²C-bus specification.
2. This value gives the auto-clock pulse length which meets the I²C-bus specification for the special crystal frequency. Alternatively, the SCL pulse must be timed by software.
3. The rise time is determined by the external bus line capacitance and pull-up resistor. It must be less than 1 μs.
4. The maximum capacitance on bus lines SDA and SCL is 400 pF.

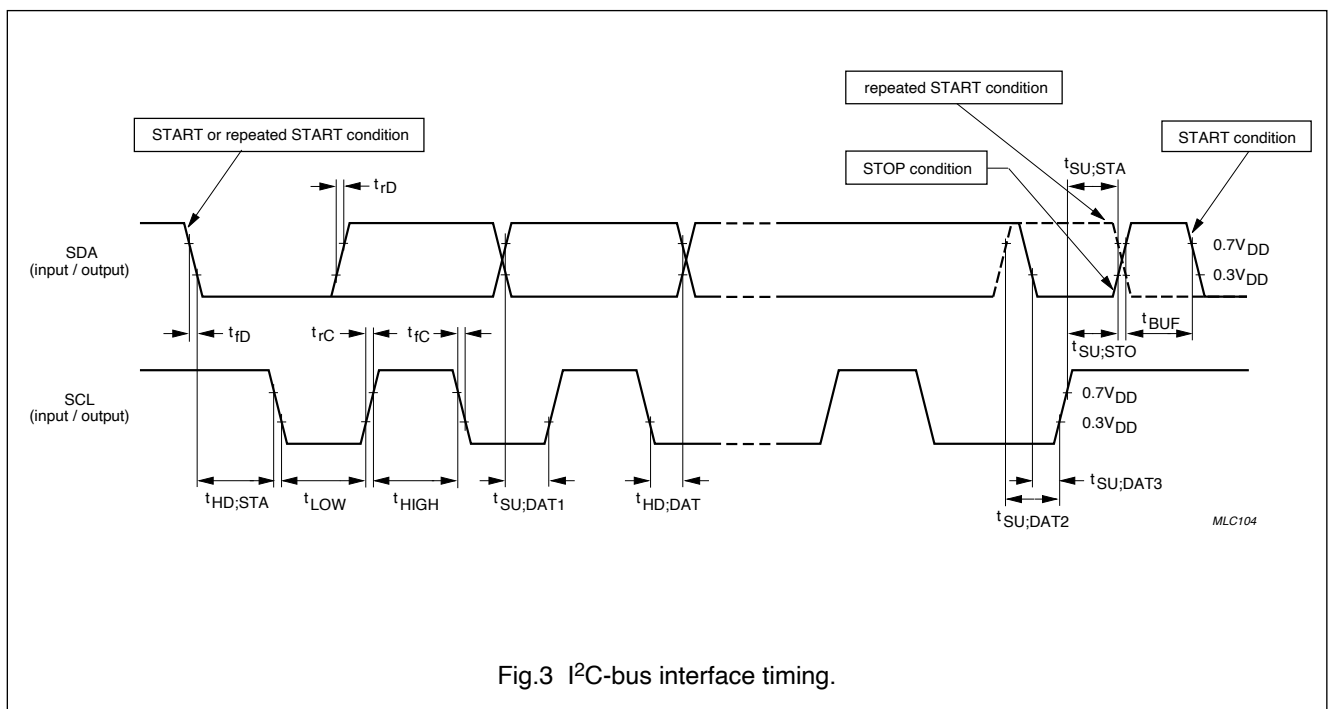

Fig.3 I²C-bus interface timing.

One page Economy Teletext/TV microcontroller

SAA5290

FUNCTIONAL DESCRIPTION

Introduction

The SAA5290 is an integrated teletext decoder and microcontroller. The teletext decoder is derived from the SAA5254 single page teletext decoder IC, with a number of enhancements to increase its suitability for on-screen display applications. The microcontroller is a derivative of the industry standard 80C51 microcontroller. A block diagram of the SAA5290 is given in Fig.1.

Microcontroller

The functionality of the microcontroller used on the SAA5290 is described here with reference to the industry standard 80C51 microcontroller. A full description of its functionality can be found in the handbook *80C51-based 8-bit microcontrollers IC20*. Using the 80C51 as a reference, the changes made for the SAA5290 fall into two categories, features not supported by the SAA5290 and features found on the SAA5290 but not supported by the 80C51.

80C51 features not supported by the SAA5290

INTERRUPT PRIORITY

The IP SFR is not implemented and all interrupts are treated with the same priority level. The SAA5290 retains the normal prioritization of interrupts within a level.

Table 6 Interrupts and their vector addresses

EVENT	PROGRAM MEMORY ADDRESS
Reset	000H
External INT0	003H
Timer 0	00BH
External INT1	013H
Timer 1	01BH
I ² C-bus	053H

OFF-CHIP MEMORY

The SAA5290 does not support the use of off-chip program memory or off-chip data memory. This means that the SAA5290 does not have any of \overline{EA} , \overline{RD} , \overline{WR} , \overline{ALE} or \overline{PSEN} pins. The 4 MOVX instructions which move data to and from external RAM should not be used.

IDLE AND POWER-DOWN MODES

Idle and power-down modes are not supported by the SAA5290. As a consequence, the respective bits in PCON are not available.

UART FUNCTION

The 80C51 UART is not available in the SAA5290. As a consequence the SCON and SBUF SFRs are removed and the ES bit in the IE SFR is unavailable.

Additional features for the SAA5290

The following features are provided by the SAA5290 in addition to the standard 80C51 features.

INTERRUPTS

The external INT1 interrupt is modified to generate an interrupt on both the rising and falling edges of the INT1 pin, when EX1 bit is set. This facility allows for software pulse width measurement for handling of a remote control.

BIT LEVEL I²C-BUS INTERFACE

The bit-level serial I/O supports the I²C-bus. P1.6/SCL and P1.7/SDA are the serial I/O pins. These two pins meet the I²C-bus specification concerning the input levels and output drive capability. Consequently, these pins have an open-drain output configuration. All the four following modes of the I²C-bus are supported.

- Master transmitter
- Master receiver
- Slave transmitter

One page Economy Teletext/TV microcontroller

SAA5290

- Slave receiver.

The advantages of the bit-level I²C-bus hardware, compared with a full software I²C-bus implementation are:

- The hardware can generate the SCL pulse
- Testing a single bit (RBF or WBF respectively) is sufficient as a check for error-free transmission.

The bit-level I²C-bus hardware operates on serial bit level and performs the following functions:

- Filtering the incoming serial data and clock signals
- Recognizing the START condition
- Generating a serial interrupt request SI after reception of a START condition and the first falling edge of the serial clock
- Recognizing the STOP condition
- Recognizing a serial clock pulse on the SCL line
- Latching a serial bit on the SDA line (SDI)
- Stretching the SCL LOW period of the serial clock to suspend the transfer of the next serial data bit
- Setting Read Bit Finished (RBF) when the SCL clock pulse has finished and Write Bit Finished (WBF) if there is no arbitration loss detected (i.e. SDA = logic 0 while SDO = logic 1)
- Setting a serial clock LOW-to-HIGH detected (CLH) flag
- Setting a Bus Busy (BB) flag on a START condition and clearing this flag on a STOP condition
- Releasing the SCL line and clearing the CLH, RBF and WBF flags to resume transfer to the next serial data bit
- Generating an automatic clock if the single bit data register S1BIT is used in master mode.

The following functions must be done in software:

- Handling the I²C-bus START interrupts
- Converting serial data to parallel data when receiving
- Converting parallel data to serial data when transmitting
- Comparing the received slave address with its own address
- Interpreting the acknowledge information
- Guarding the I²C-bus status if RBF or WBF = logic 0.

Additionally, if acting as master:

- Generating START and STOP conditions
- Handling bus arbitration
- Generating serial clock pulses if S1BIT is not used.

Three SFRs support the function of the bit-level I²C-bus hardware, they are S1INT, S1BIT and S1SCS.

LED SUPPORT

Port pins P0.5 and P0.6 have a 10 mA current sinking capability to enable LEDs to be driven directly.

PWM DACs

The SAA5290 has six 6-bit PWM DACs and one 14-bit PWM DAC. These allow direct control of other parts of the television.

The low resolution 6 bit DACs are controlled by their corresponding SFR (PWM0 to PWM5) and are connected as alternative outputs of Port P2. The port bit corresponding to the PWM should be set to logic 1 for correct operation of the PWM.

Table 7 Special Function Registers PWM0 to PWM5

D7	D6	D5	D4	D3	D2	D1	D0
PWE	–	PV5	PV4	PV3	PV2	PV1	PV0

If the PWE bit for a particular port is set to logic 1, the PWM is active and controls its assigned port pin. If the PWE bit is set to logic 0 the corresponding port pin is controlled by the bit in the corresponding port register for that port.

The output of the PWM is a pulse of period 21.33 μ s with a duty cycle determined by the binary value, PV5 to PV0, multiplied by 0.33 μ s. The 14 bit PWM is controlled with SFR registers TDACL and TDACH.

Table 8 Special Function Register TDACL

D7	D6	D5	D4	D3	D2	D1	D0
TD7	TD6	TD5	TD4	TD3	TD2	TD1	TD0

Table 9 Special Function Register TDACH

D7	D6	D5	D4	D3	D2	D1	D0
PWE	–	TD13	TD12	TD11	TD10	TD9	TD8

If the PWE bit is set to logic 1, the TPWM is active and controls Port P2.0. If the PWE bit is set to logic 0 the port pin is controlled by the bit in the corresponding port register for P2.0.

The output of the TPWM is a pulse of period 42.66 μ s with a duty cycle determined by the binary value, TD13 to TD7, multiplied by 0.33 μ s.

One page Economy Teletext/TV microcontroller

SAA5290

The 7 least significant bits, TD6 to TD0, extend the HIGH time of a proportion of the pulses by 0.33 μ s. If the LSB is set then 1 in 128 cycles is extended, if bit 1 is set then 1 in 64 cycles is extended, and so on.

SOFTWARE ADC

Up to 3 successive approximation ADCs can be implemented in software by making use of the on-board 4-bit DAC and multiplexed voltage comparator. The software ADC uses 3 analog inputs which are multiplexed with P3.0 to P3.2.

The control of the ADC is achieved using the SAD SFR. SAD.5 and SAD.6 select one of the three inputs to pass to the comparator. The other input comes from the DAC whose input is set by SAD bits 0 to 3. The output of the comparator is SAD bit 7 and is valid by the next instruction after starting the comparison by setting SAD.ST to logic 1.

Microcontroller interfacing

The 80C51 CPU communicates with the peripheral functions using Special Function Registers (SFRs) which are addressed as RAM locations. The registers in the teletext decoder appear as normal SFRs in the microcontroller memory map, but are written to using a serial bus. This bus is controlled by dedicated hardware which uses a simple handshake system for software synchronization. The SFR memory map is given in Table 10.

One page Economy Teletext/TV
microcontroller

SAA5290

Table 10 SAA5290 Special Function Register map (note 1)

SYMBOL	DESCR.	DIRECT ADDR. (HEX)	BIT ADDRESS, SYMBOL OR ALTERNATIVE PORT FUNCTION																RESET VALUE (HEX)	
			MSB								LSB									
ACC ⁽²⁾	Accumulator	E0H	E7	E6	E5	E4	E3	E2	E1	E0										00H
B ⁽²⁾	B register	F0H	F7	F6	F5	F4	F3	F2	F1	F0										00H
DPTR:	Data Pointer (2 bytes):																			
DPH	High byte	83H	-	-	-	-	-	-	-	-	-	-	-	-	-	-	-	-	-	00H
DPL	Low byte	82H	-	-	-	-	-	-	-	-	-	-	-	-	-	-	-	-	-	00H
IE ⁽²⁾⁽³⁾	Interrupt Enable	A8H	AF	AE	AD	AC	AB	AA	A9	A8									X0H	
			EA	ES1	*	*	ET1	EX1	ET0	EX0										
P0 ⁽²⁾	Port 0	80H	87	86	85	84	83	82	81	80									FFH	
P1 ⁽²⁾	Port 1	90H	97	96	95	94	93	92	91	90									FFH	
P2 ⁽²⁾	Port 2	A0H	A7	A6	A5	A4	A3	A2	A1	A0									FFH	
P3 ⁽²⁾⁽³⁾	Port 3	B0H	-	-	-	B4	B3	B2	B1	B0									XXX11111B	
PCON ⁽³⁾	Power Control	87H	*	*	*	*	GF1	GF0	*	*									XXXX00XXB	
PSW ⁽²⁾	Program Status Word	D0H	D7	D6	D5	D4	D3	D2	D1	D0									000000X0B	
			CY	AC	F0	RS1	RS0	0V	*	P										
PWM0 ⁽³⁾	Pulse Width Modulator 0	D5H	PWE	*	PV5	PV4	PV3	PV2	PV1	PV0									-	
PWM1 ⁽³⁾	Pulse Width Modulator 1	D6H	PWE	*	PV5	PV4	PV3	PV2	PV1	PV0									-	
PWM2 ⁽³⁾	Pulse Width Modulator 2	D7H	PWE	*	PV5	PV4	PV3	PV2	PV1	PV0									-	
PWM3 ⁽³⁾	Pulse Width Modulator 3	DCH	PWE	*	PV5	PV4	PV3	PV2	PV1	PV0									-	
PWM4 ⁽³⁾	Pulse Width Modulator 4	DDH	PWE	*	PV5	PV4	PV3	PV2	PV1	PV0									-	
PWM5 ⁽³⁾	Pulse Width Modulator 5	DEH	PWE	*	PV5	PV4	PV3	PV2	PV1	PV0									-	
S1BIT ⁽³⁾	Serial I ² C data	D9H	SDI/ SDO	*	*	*	*	*	*	*									00H	

One page Economy Teletext/TV
microcontroller

SAA5290

SYMBOL	DESCR.	DIRECT ADDR. (HEX)	BIT ADDRESS, SYMBOL OR ALTERNATIVE PORT FUNCTION																RESET VALUE (HEX)
			MSB								LSB								
S1INT ⁽³⁾	Serial I ² C interrupt	DAH	SI	*	*	*	*	*	*	*	*	*	*	*	*	*	*	*	-
S1SCS ⁽²⁾⁽³⁾	Serial I ² C control	D8H	DF	DE	DD	DC	DB	DA	DA	D9	D8	STR	ENS						-
			SDI/SDO	SCI/SDO	CLH	BB	RBF	WBF											
SAD ⁽²⁾⁽³⁾	Software A to D	E8H	EF	EE	ED	EC	EB	EA	EA	E9	E8								00H
			VHI	CH1	CH0	ST	SAD3	SAD2	SAD1	SAD0									
SP	Stack Pointer	81H	8F	8E	8D	8C	8B	8A	8A	89	88								07H
TCON ⁽²⁾	Timer/counter control	88H	TF1	TR1	TF0	TR0	IE1	IT1	IT1	IE0	IT0								00H
TDACH	TPWM High byte	D3H	PWE	*	TD13	TD12	TD11	TD10	TD10	TD9	TD8								00H
TDACL	TPWM Low byte	D2H	TD7	TD6	TD5	TD4	TD3	TD2	TD2	TD1	TD0								00H
TH0	Timer 0 High byte	8CH	-	-	-	-	-	-	-	-	-								00H
TH1	Timer 1 High byte	8DH	-	-	-	-	-	-	-	-	-								00H
TL0	Timer 0 Low byte	8AH	-	-	-	-	-	-	-	-	-								00H
TL1	Timer 1 Low byte	8BH	-	-	-	-	-	-	-	-	-								00H
TMOD	Timer/counter mode	89H	GATE	C/T	M1	M0	GATE	C/T	C/T	M1	M0								00H
TXT0 ⁽³⁾	Teletext register 0	C0H	X24 POS	*	AUTO FRAME	DISABLE HDR ROLL	DISPLAY STATUS ROW ONLY	DISABLE FRAME	DISABLE FRAME	*	*								00H
TXT1 ⁽³⁾	Teletext register 1	C1H	*	8-BIT	ACQ OFF	X26	FULL FIELD	FIELD POLARITY	FIELD POLARITY	H	V								00H
TXT2 ⁽³⁾	Teletext register 2	C2H	*	*	*	*	*	SC2	SC2	SC1	SC0								00H
TXT3 ⁽³⁾	Teletext register 3	C3H	*	*	*	PRD4	PRD3	PRD2	PRD2	PRD1	PRD0								00H

One page Economy Teletext/TV microcontroller

SAA5290

SYMBOL	DESCR.	DIRECT ADDR. (HEX)	BIT ADDRESS, SYMBOL OR ALTERNATIVE PORT FUNCTION													RESET VALUE (HEX)			
			MSB						LSB										
TXT4 ⁽³⁾	Teletext register 4	C4H	*	*															00H
TXT5 ⁽³⁾	Teletext register 5	C5H	BKGND OUT	BKGND IN	COR OUT	COR IN	COR IN	COR IN	COR IN	COR IN	COR IN	COR IN	COR IN	COR IN	COR IN	COR IN	COR IN	COR IN	00000011B
TXT6 ⁽³⁾	Teletext register 6	C6H	BKGND OUT	BKGND IN	COR OUT	COR IN	COR IN	COR IN	COR IN	COR IN	COR IN	COR IN	COR IN	COR IN	COR IN	COR IN	COR IN	COR IN	00000011B
TXT7 ⁽³⁾	Teletext register 7	C7H	STATUS ROW TOP	CURSOR ON	CONCEAL /REVEAL	TOP/BTM	TOP/BTM	TOP/BTM	TOP/BTM	TOP/BTM	TOP/BTM	TOP/BTM	TOP/BTM	TOP/BTM	TOP/BTM	TOP/BTM	TOP/BTM	TOP/BTM	00H
TXT8 ⁽³⁾	Teletext register 8	C8H	*	*	*	*	*	*	*	*	*	*	*	*	*	*	*	CVBS0/ CVBS1	00H
TXT9 ⁽³⁾	Teletext register 9	C9H	*	CLEAR MEM.	A0	R4	R3	R2	R1	R0	R0	R0	R0	R0	R0	R0	R0	R0	00H
TXT10 ⁽³⁾	Teletext register 10	CAH	*	*	C5	C4	C3	C2	C1	C0	C0	C0	C0	C0	C0	C0	C0	C0	00H
TXT11 ⁽³⁾	Teletext register 11	CBH	D7	D6	D5	D4	D3	D2	D1	D0	D0	D0	D0	D0	D0	D0	D0	D0	00H
TXT12 ⁽³⁾	Teletext register 12	CCH	625/525 SYNC	ROM VER R4	ROM VER R3	ROM VER R2	ROM VER R1	ROM VER R0	TXT ON	VIDEO QUALITY	VIDEO QUALITY	VIDEO QUALITY	VIDEO QUALITY	VIDEO QUALITY	VIDEO QUALITY	VIDEO QUALITY	VIDEO QUALITY	VIDEO QUALITY	
TXT13 ⁽²⁾⁽³⁾	Teletext register 13	B8H	BF	BE	BD	BC	BB	BA	B9	B8	B8	B8	B8	B8	B8	B8	B8	B8	00H
			*	*	*	*	*	*	*	*	*	*	*	*	*	*	*	TXT I/FACE BUSY	

Notes

1. The star (*) indicates these bits are inactive and must be written to logic 0 for future compatibility.
2. SFRs are bit addressable.
3. SFRs are modified or added to the 80C51 SFRs.

One page Economy Teletext/TV microcontroller

SAA5290

Table 11 SFR description

REGISTER	FUNCTION
IE - Interrupt Enable	
EA	Disable all interrupts (logic 0) or use individual enable bits (logic 1).
ES1	I ² C-bus interrupt enable (logic 1).
ET1	Enable Timer 1 overflow interrupt (logic 1).
EX1	Enable external interrupt 1 (logic 1).
ET0	Enable Timer 0 overflow interrupt (logic 1).
EX0	Enable external interrupt 0 (logic 1).
PCON - Power Control	
GF0	General purpose flag bit 0.
GF1	General purpose flag bit 1.
PWM0 to PWM5 - 6-bit Pulse Width Modulator control registers	
PWE	Activate this 6-bit PWM and take over port pin (logic 1).
PV0 to PV5	Value to output by this 6-bit PWM.
SAD - Software ADC control	
VHI	Analog input voltage greater than DAC output voltage (logic 1).
CH0 and CH1	See Table 12.
ST	Initiate voltage comparison (logic 1). This is automatically reset.
SAD0 to SAD3	4-bit DAC input value. The DAC output of this value is compared with analog input voltage.
S1BIT - Serial I²C-bus data (READ)	
SDI	I ² C-bus data bit latched-in from SDA on the last rising edge of SCL.
S1BIT - Serial I²C-bus data (WRITE)	
SDO	I ² C-bus data bit output.
S1INT - Serial I²C-bus interrupt	
SI	I ² C-bus interrupt flag.
S1SCS - Serial I²C-bus control (READ)	
SDI	Serial data input at SDA.
SCI	Serial clock input at SCL.
CLH	Clock LOW-to-HIGH transition flag.
BB	Bus busy flag.
RBF	Read bit finished flag.
WBF	Write bit finished flag.
STR	Clock stretching enable (logic 1).
ENS	Enable serial I/O (logic 1).

One page Economy Teletext/TV microcontroller

SAA5290

REGISTER	FUNCTION
S1SCS - Serial I²C-bus control (WRITE)	
SDO	Serial data output at SDA.
SCO	Serial clock output at SCL.
CLH	Clock LOW-to-HIGH transition.
STR	Clock stretching enable (logic 1).
ENS	Enable serial I/O (logic 1).
TDACH - 14-bit PWM MSB register	
PWE	Activate this 14-bit PWM and take over port pin (logic 1).
TD8 to TD13	6 LSBs of this value to be output by the 14-bit PWM.
TDACL - 14-bit PWM LSB register	
TD0 to TD7	8 LSBs of this value to be output by the 14-bit PWM.
TXT0 - Teletext register 0 (WRITE only)	
X24 POSITION	Store packet 24 in extension packet memory (logic 0) or page memory (logic 1).
AUTO FRAME	Frame output switched off automatically if any video displayed (logic 1).
DISABLE HDR ROLL	Do not write rolling headers and time into memory (logic 1).
STATUS ROW ONLY	Display only memory row (logic 1).
DISABLE FRAME	Frame output always LOW (logic 1).
TXT1 - Teletext register 1 (WRITE only)	
8-BIT	Data in packets 0 to 24 written into memory without error checking (logic 1).
ACQ OFF	Prevent teletext acquisition section writing to memory (logic 1).
X26	Disable automatic processing of packet 26 data (logic 1).
FULL FIELD	Accept teletext on TV lines 2 to 22 only (logic 0) or on any line (logic 1).
FIELD POLARITY	VSYNC in first half of the line (logic 0) or second half of the line (logic 1) at start of even field.
H POLARITY	HSYNC input positive-going (logic 0) or negative-going (logic 1).
V POLARITY	VSYNC input positive-going (logic 0) or negative-going (logic 1).
TXT2 - Teletext register 2 (WRITE only)	
SC0 to SC2	Start column at which page request data written into TXT3 SFR is placed.
TXT3 - Teletext register 3 (WRITE only)	
PRD0 to PRD4	Page request data.
TXT4 - Teletext register 4 (WRITE only)	
B MESH ENABLE	Enable meshing of area with black background (logic 1).
C MESH ENABLE	Enable meshing of area with other background colours (logic 1).
TRANS ENABLE	Black background colour is transparent i.e. video is displayed (logic 1).
SHADOW ENABLE	Enable south-east shadowing (logic 1).
EAST/WEST	Western European languages displayed (logic 0) or Eastern European languages displayed (logic 1).

One page Economy Teletext/TV microcontroller

SAA5290

REGISTER	FUNCTION
TXT5 - Teletext register 5 (WRITE only)	
BKGND OUT	Background colour displayed outside teletext boxes (logic 1).
BKGND IN	Background colour displayed inside teletext boxes (logic 1).
$\overline{\text{COR}}$ OUT	$\overline{\text{COR}}$ output active outside teletext boxes (logic 1).
$\overline{\text{COR}}$ IN	$\overline{\text{COR}}$ output active inside teletext boxes (logic 1).
TEXT OUT	Text displayed outside teletext boxes (logic 1).
TEXT IN	Text displayed inside teletext boxes (logic 1).
PICTURE ON OUT	Video picture displayed outside teletext boxes (logic 1).
PICTURE ON IN	Video picture displayed inside teletext boxes (logic 1).
TXT6 - Teletext register 6 (WRITE only)	
-	This register has the same meaning as TXT5 but is only invoked if either newflash (C5) or the subtitle (C6) bit in Row 25 of the basic page memory is set.
TXT7 - Teletext register 7 (WRITE only)	
STATUS ROW TOP	Display Row 24 below (logic 0) or above (logic 1) teletext page.
CURSOR ON	Display cursor at location pointed to by TXT9 and TXT10 (logic 1).
$\overline{\text{CONCEAL/REVEAL}}$	Display characters in areas with the conceal attribute set (logic 1).
$\overline{\text{TOP/BOTTOM}}$	Display Rows 0 to 11 (logic 0) or 12 to 23 (logic 1) when the double height bit is set.
$\overline{\text{SNG/DBL HEIGHT}}$	Display each character at twice normal height (logic 1).
BOX ON 24	Enable teletext boxes in memory Row 24 (logic 1).
BOX ON 1-23	Enable teletext boxes in memory Rows 1 to 23 (logic 1).
BOX ON 0	Enable teletext boxes in memory Row 0 (logic 1).
TXT8 - Teletext register 8 (WRITE only)	
$\overline{\text{CVBS0/CVBS1}}$	CVBS0 input (logic 0) or CVBS1 (logic 1) inputs used for teletext.
TXT9 - Teletext register 9 (WRITE only)	
CLEAR MEMORY	Write 20H into every location in teletext memory (logic 1).
A0	Access basic page memory (logic 0) or extension packet memory (logic 1) with TXT11 SFR.
R0 to R4	Memory row to be accessed with TXT11 SFR.
TXT10 - Teletext register 10 (WRITE only)	
C0 to C5	Memory column to be accessed with TXT11 SFR.
TXT11 - Teletext register 11	
D0 to D7	data byte written to, or read from, teletext memory.

One page Economy Teletext/TV microcontroller

SAA5290

REGISTER	FUNCTION
TXT12 - Teletext register 12 (READ only)	
625/525 SYNC	A 625 line CVBS signal (logic 0), or a 525 line CVBS signal (logic 1) is being input.
ROM VER R0 to R4	Mask programmable to identify character set version.
TXT ON	Teletext power has been applied to the device (logic 1).
VIDEO QUALITY	CVBS input can be locked on by the teletext decoder (logic 1).
TXT13 - Teletext register 13 (READ only)	
TXT I/FACE BUSY	Text interface busy and no access for either READ or WRITE is allowed to SFRs TXT0 to TXT11 (logic 1). This register bit performs the software handshake to the teletext control registers.

Table 12 CH1 and CH0 selection

CH1	CH0	INPUT PIN
0	0	none
0	1	ADC0
1	0	ADC1
1	1	ADC2

One page Economy Teletext/TV microcontroller

SAA5290

TELETEXT DECODER FUNCTIONAL DESCRIPTION

Data slicer

The data slicer extracts the digital teletext data from the incoming analog waveform. This is performed by sampling the CVBS waveform and processing the samples to extract the teletext data and clock.

Acquisition timing

The acquisition timing is generated from a logic level positive-going composite sync signal 'VCS'. This signal is generated by the sync separator circuit which adaptively slices the sync pulses at 50% of their height. It is able to do this over a wide range of sync amplitudes by using the same basic principle used on VIP1 (SAA5230) and VIP2 (SAA5231).

Figure 4 is a block diagram showing the principles of operation. It relies upon the fact that the ratio of the sync width to the line time is approximately 13 : 1. In order to slice the sync pulse at the correct 50% level two currents are generated.

One is constant and is proportional to the difference between the black level of the video and the slicing level. The other is produced only when the video is below the slicing level, and is also proportional to the difference between the slicing level and the input, but has a magnitude 13 times greater.

The black level is determined by a sync-gated peak detector. The video is negatively peak detected into an external capacitor (BLACK, pin 25), but not during the sync pulse VCS. The two currents are integrated on the CVBS input coupling capacitor and the net effect is to alter the mean input voltage until the (fixed) slicing level is correct.

The acquisition clocking and timing are locked to the VCS signal using a digital phased-locked-loop. The phase error in the acquisition phase-locked-loop is detected by a signal quality circuit which disables acquisition if poor signal quality is detected.

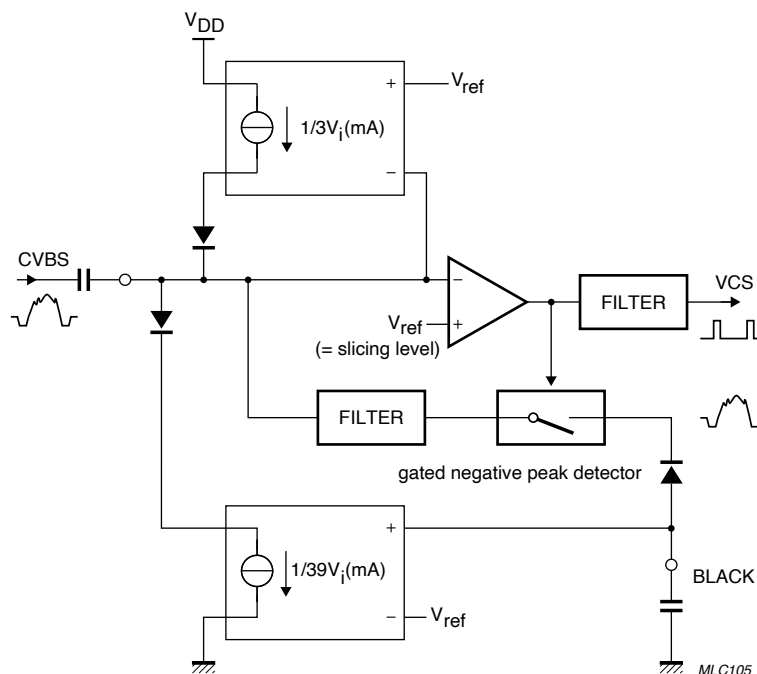

Fig.4 Sync separator block diagram.

One page Economy Teletext/TV microcontroller

SAA5290

Teletext acquisition

The SAA5290 is able to acquire 625-line World System Teletext. Teletext is acquired under control of the on-board 80C51 microcontroller. Pages are requested by writing a series of bytes into the TXT3 SFR which corresponds to the number of the page required. The bytes written into TXT3 are put into a small RAM with an auto-incrementing address. The start address for the RAM is set using the SFR TXT2 register. Table 13 shows the contents of the page request RAM.

If the 'DO CARE' bit for part of the page number is set to logic 0 then that part of the page number is ignored when the acquisition section is deciding whether a page being received off air should be stored or not. For example if the 'DO CARE' bits for the 4 subcode digits are all set to logic 0 then every subcode version of the page will be captured.

When the 'HOLD' bit is set to logic 0 the acquisition section will not recognize any page as having the correct page number and no pages will be captured.

Table 13 Register map for page requests (TXT3); note 1

START COLUMN	PRD4	PRD3	PRD2	PRD1	PRD0
0	DO CARE Magazine	$\overline{\text{HOLD}}$	MAG2	MAG1	MAG0
1	DO CARE Page tens	PT3	PT2	PT1	PT0
2	DO CARE Page units	PU3	PU2	PU1	PU0
3	DO CARE Hours tens	X	X	HT1	HT0
4	DO CARE Hours units	HU3	HU2	HU1	HU0
5	DO CARE Minutes tens	X	MT2	MT1	MT0
6	DO CARE Minutes units	MU3	MU2	MU1	MU0

Note

1. X = don't care.

Page memory organization

The acquired teletext packets each contain 40 bytes of data and one packet is stored in each row of the text memory. The page memory organization is given in Fig.5. Rows 0 to 23 form the teletext page; Row 24 is available for status messages and FLOF/FASTEXT prompt information.

One page Economy Teletext/TV microcontroller

SAA5290

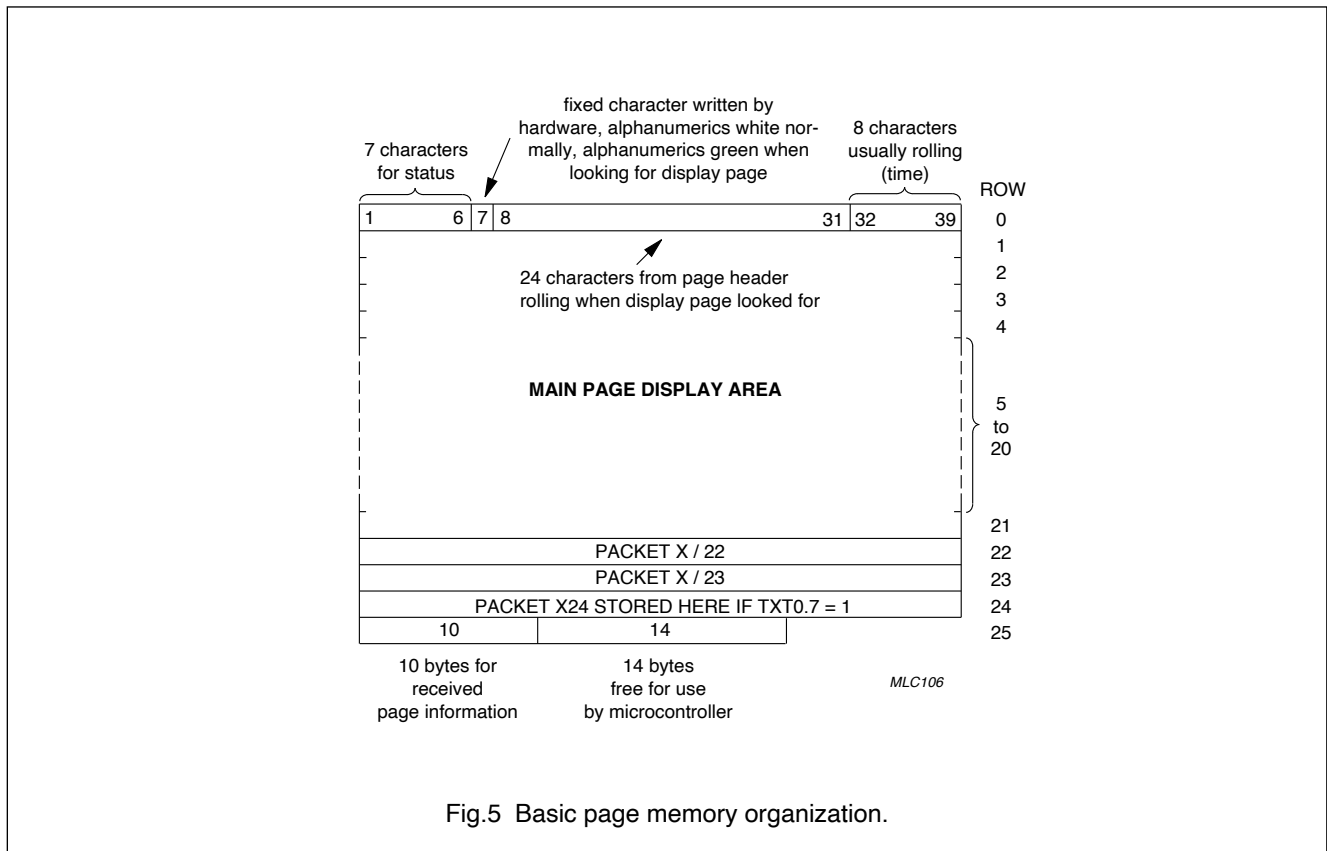

Fig.5 Basic page memory organization.

Row 0 (see Fig.5)

Row 0 is for the page header. The first seven characters (0 to 6) are free for status messages. Character 8 is an alphanumeric white or green control character, written automatically by SAA5290 to give a green rolling header when a page is being looked for. The last eight characters are for rolling time.

Row 25 (see Fig.5)

The first 10 bytes of row 25 contain control data relating to the received page as shown in Table 14. The remaining 14 bytes are free for use by the microcontroller.

Extension packet memory organization

If TXT0.X24 POS bit is set to logic 0, then Packet 24 is written into Row 0 of the extension memory.

Packet X27/0 is written to Row 1 of the extension memory, with bytes 0 to 37 being Hamming checked automatically.

Packet 8/30 is written to Row 2 of the extension memory, with bytes 0 to 6 being 8/4 Hamming checked, bytes 7 to 19 unchecked and bytes 20 to 39 odd parity checked.

Packet 26 processing

The SAA5290 contains on-board hardware processing of Packet 26 data. If a character corresponding to that being transmitted is available in the character set then the correct character code is written into the display memory.

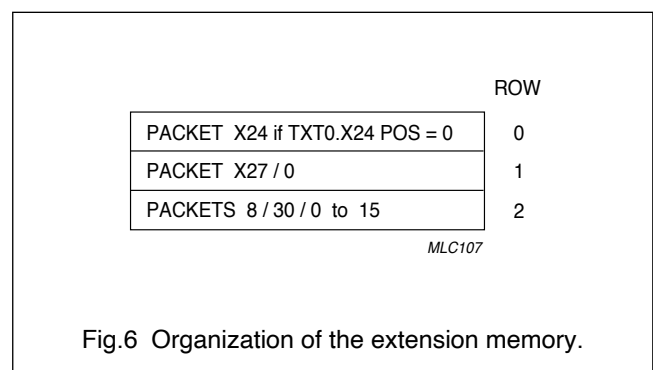

Fig.6 Organization of the extension memory.

One page Economy Teletext/TV microcontroller

SAA5290

Table 14 Row 25 received control data format

ROW 25										
D0	PU0	PT0	MU0	MT0	HU0	HT0	C7	C11	MAG0	0
D1	PU1	PT1	MU1	MT1	HU1	HT1	C8	C12	MAG1	0
D2	PU2	PT2	MU2	MT2	HU2	C5	C9	C13	MAG2	0
D3	PU3	PT3	MU3	C4	HU3	C6	C10	C14	0	0
D4	HAM.ER	HAM.ER	HAM.ER	HAM.ER	HAM.ER	HAM.ER	HAM.ER	HAM.ER	FOUND	0
D5	0	0	0	0	0	0	0	0	0	PBLF
D6	0	0	0	0	0	0	0	0	0	0
D7	0	0	0	0	0	0	0	0	0	0
Column	0	1	2	3	4	5	6	7	8	9

Table 15 Page number and sub-code for Table 14

BIT NAME	DESCRIPTION
Page number	
MAG	magazine
PU	page units
PT	page tens
PBLF	page being looked for
HAM.ER	Hamming error in corresponding byte
Page sub-code	
MU	minutes units
MT	minutes tens
HU	hours units
HT	hours tens
C4 to C14	transmitted control bits

One page Economy Teletext/TV microcontroller

SAA5290

Display

The capabilities of the display are based on the requirements of level 1 teletext, with some enhancements for use with locally generated On-Screen Displays (OSD).

The display consists of 25 rows each of 40 characters, with the characters displayed being those from Rows 0 to 24 of the basic page memory. The page memory stores 8-bit character codes which correspond to 260 displayable characters and 44 control codes, normally displayed as spaces. Each character is defined by a matrix 12 pixels high and 10 pixels deep. When displayed each pixel is 0.5 μ s wide and 1 TV line, in each field, high.

The SAA5290 signals the TV display circuits to display the RGB outputs of the SAA5290 rather than video picture by setting VDS HIGH. The way in which this signal is switched is controlled by the TXT5 and TXT6 SFRs. There are three control functions: background on, text on and picture on. There are separate bits for each function for inside and outside teletext boxes and if the newsflash or subtitle bits are set. This allows the software to configure the type of display required. The effect of the combination of these bits is given in Table 16. The COR bits in Register 5 and Register 6 control when the output is pulled LOW. This output is intended to act on the TV display circuits to reduce the contrast of the video display.

The display character set is given in Fig.9. The character set provided contains all the characters required to display Eastern and Western European languages. Register bit TXT4.EAST/ WEST sets whether Eastern or Western languages are set with the C12 to C14 bits. In order to make on-screen displays easy to use, the SAA5290 contains additional display attributes in Column 11.

Control codes are categorized as 'set at' or 'set after'. 'Set at' means the code has effect at the current character position and 'set after' means they have effect from the following character. Codes 11/0 to 11/7 are always 'set at'. Codes 11/11 to 11/15 are 'set after' when defining the start of an OSD box and 'set at' when ending an OSD box. Codes 11/12 to 11/15 force a box condition allowing on-screen display messages to be displayed without having to erase the whole contents of the teletext page.

On-screen displays are only available in TV mode and not in text mode. In mixed text and TV mode the displayed screen is not defined if an OSD box is encountered in the page memory.

Table 16 Display mode

PICTURE ON	TEXT ON	BACKGROUND ON	RESULT
0	0	X	text mode, black screen
0	1	0	text mode, background always black
0	1	1	text mode
1	0	X	TV mode
1	1	0	mixed mode and TV mode
1	1	1	text mode, TV picture outside text area

Display timing

The display circuitry is driven from the H/VSYNC inputs, and is independent of the input video signal. Consequently HSYNC and VSYNC are always required to slave synchronize the display.

The FRAME output of the SAA5290 is provided to facilitate de-interlacing the teletext display. The behaviour of FRAME is controlled via the register bits TXT0.DISABLE FRAME, TXT0.AUTO FRAME and TXT1.FIELD POLARITY. If the active edge of VSYNC occurs in the first half of a TV line then the field is even, and

if the active edge of VSYNC is in the second half of a line then the field is odd. The active edge is controlled with TXT1.V POLARITY. With TXT0.AUTO FRAME LOW FRAME is HIGH for an odd field and LOW for an even field. With TXT0.AUTO FRAME HIGH FRAME is only active when text is being displayed, when video is displayed it is forced LOW. When TXT0.DISABLE FRAME is HIGH FRAME is always LOW. If TXT1.FIELD POLARITY is logic 1 then VSYNC is delayed by 32 μ s before being applied to the display timing circuits.

One page Economy Teletext/TV microcontroller

SAA5290

Clock generator

The oscillator circuit of the SAA5290 is a single-stage inverting amplifier in a Pierce oscillator configuration. The circuitry between OSCIN and OSCOUT is basically an inverter biased to the transfer point. A crystal must be used as the feedback element to complete the oscillator

circuitry. It is operated in parallel resonance. OSCIN is the high gain amplifier input and OSCOUT is the output. To drive the SAA5290 externally OSCIN is driven from an external source and OSCOUT is left open-circuit.

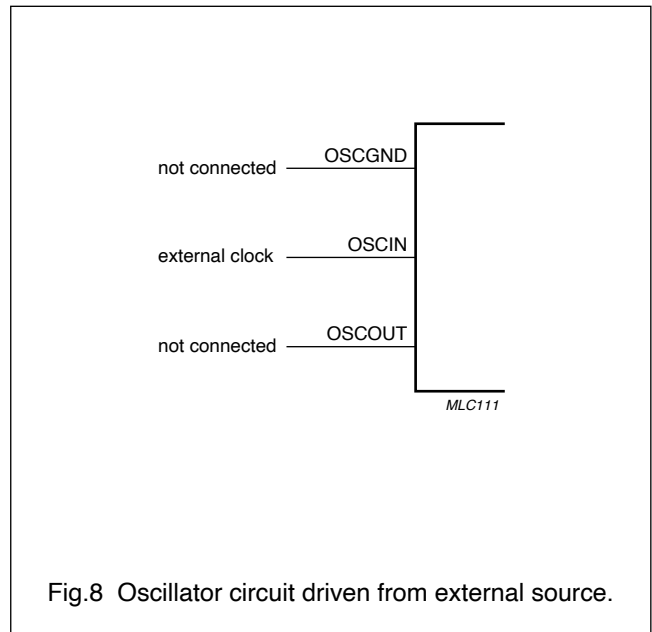
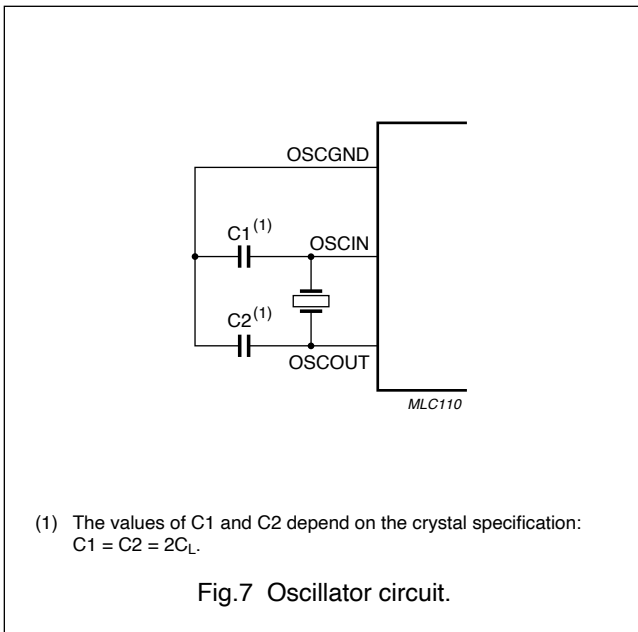

One page Economy Teletext/TV
microcontroller

SAA5290

LANGUAGE	PHCB				CHARACTER POSITION (COLUMN / ROW)												
	E/W	C12	C13	C14	2/3	2/4	4/0	5/B	5/C	5/D	5/E	5/F	6/0	7/B	7/C	7/D	7/E
ENGLISH	0	0	0	0	£	\$	@	←	½	→	↑	#	-	¼		¾	÷
GERMAN	0	0	0	1	#	\$	§	Ä	Ö	Ü	^	_	°	ä	ö	ü	ß
SWEDISH	0	0	1	0	#	Å	É	Ä	Ö	Å	Ü	_	é	ä	ö	å	ü
ITALIAN	0	0	1	1	£	\$	é	°	ç	→	↑	#	ù	à	ò	è	ì
FRENCH	0	1	0	0	é	ï	à	ë	ê	ù	î	#	è	â	ô	û	ç
SPANISH	0	1	0	1	ç	\$	í	á	é	í	ó	ú	ó	ü	ñ	è	à
TURKISH	0	1	1	0	ı	ğ	İ	Ş	Ö	Ç	Ü	Ğ	ı	Ş	ö	ç	ü
ENGLISH	0	1	1	1	£	\$	@	←	½	→	↑	#	-	¼		¾	÷
POLISH	1	0	0	0	#	ń	ą	ż	ś	ł	ć	ó	ę	ź	ś	ź	ż
GERMAN	1	0	0	1	#	\$	§	Ä	Ö	Ü	^	_	°	ä	ö	ü	ß
ESTONIAN	1	0	1	0	#	õ	š	Ä	Ö	Ž	Ü	õ	š	ä	ö	ž	ü
GERMAN	1	0	1	1	#	\$	§	Ä	Ö	Ü	^	_	°	ä	ö	ü	ß
GERMAN	1	1	0	0	#	\$	§	Ä	Ö	Ü	^	_	°	ä	ö	ü	ß
SERBO-CROAT	1	1	0	1	#	ě	č	ć	ž	đ	š	ë	č	ć	ž	đ	š
CZECHOSLOVAKIA	1	1	1	0	#	ů	č	ř	ž	ý	í	ř	é	á	ě	ú	š
RUMANIAN	1	1	1	1	#	Å	Ț	Ă	Ș	Ă	Î	ı	ț	ă	ș	ă	î

MLC109

Fig.10 SAA5290 European national option characters.

One page Economy Teletext/TV microcontroller

SAA5290

APPLICATION INFORMATION

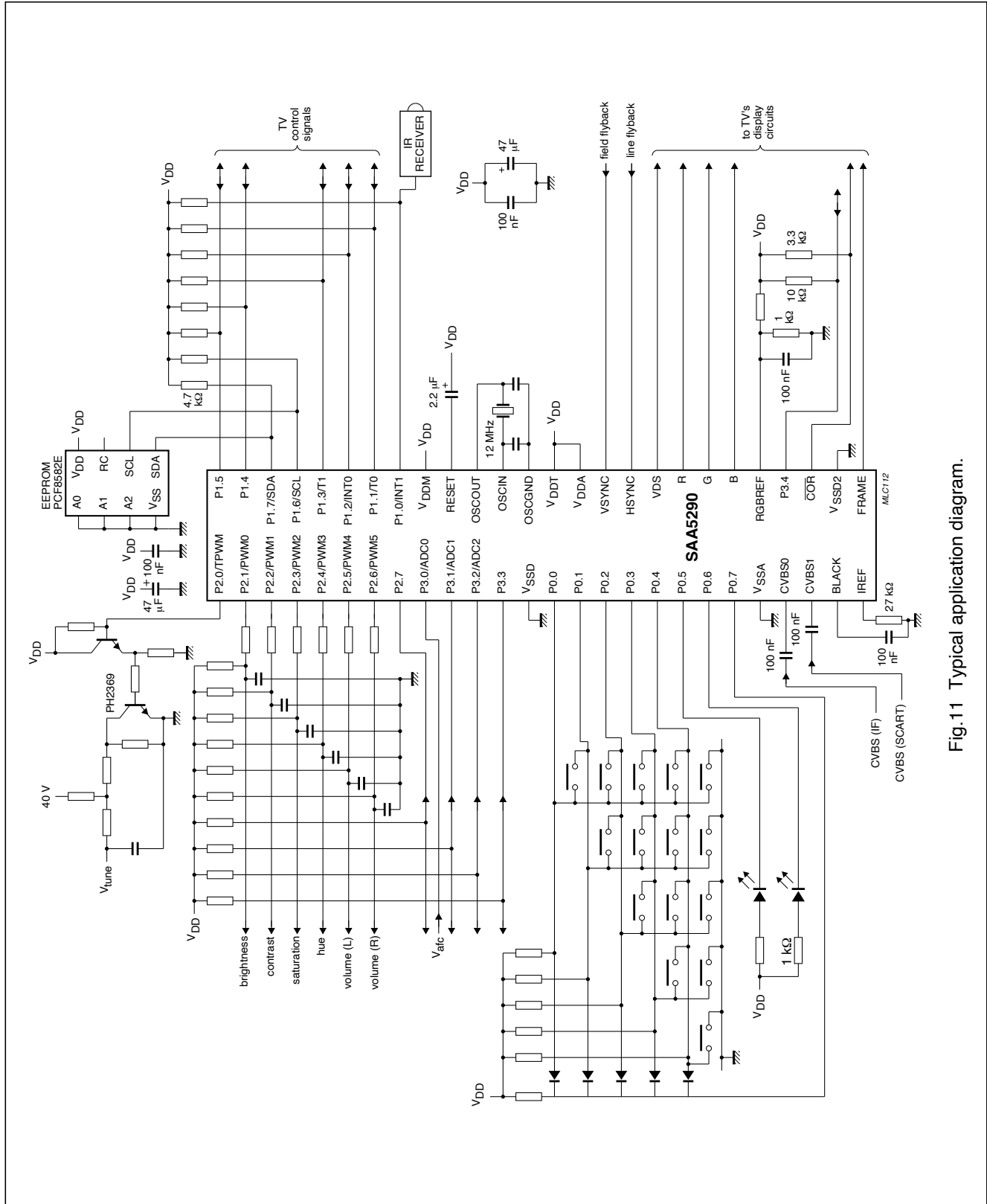

Fig.11 Typical application diagram.

One page Economy Teletext/TV microcontroller

SAA5290

PACKAGE OUTLINE

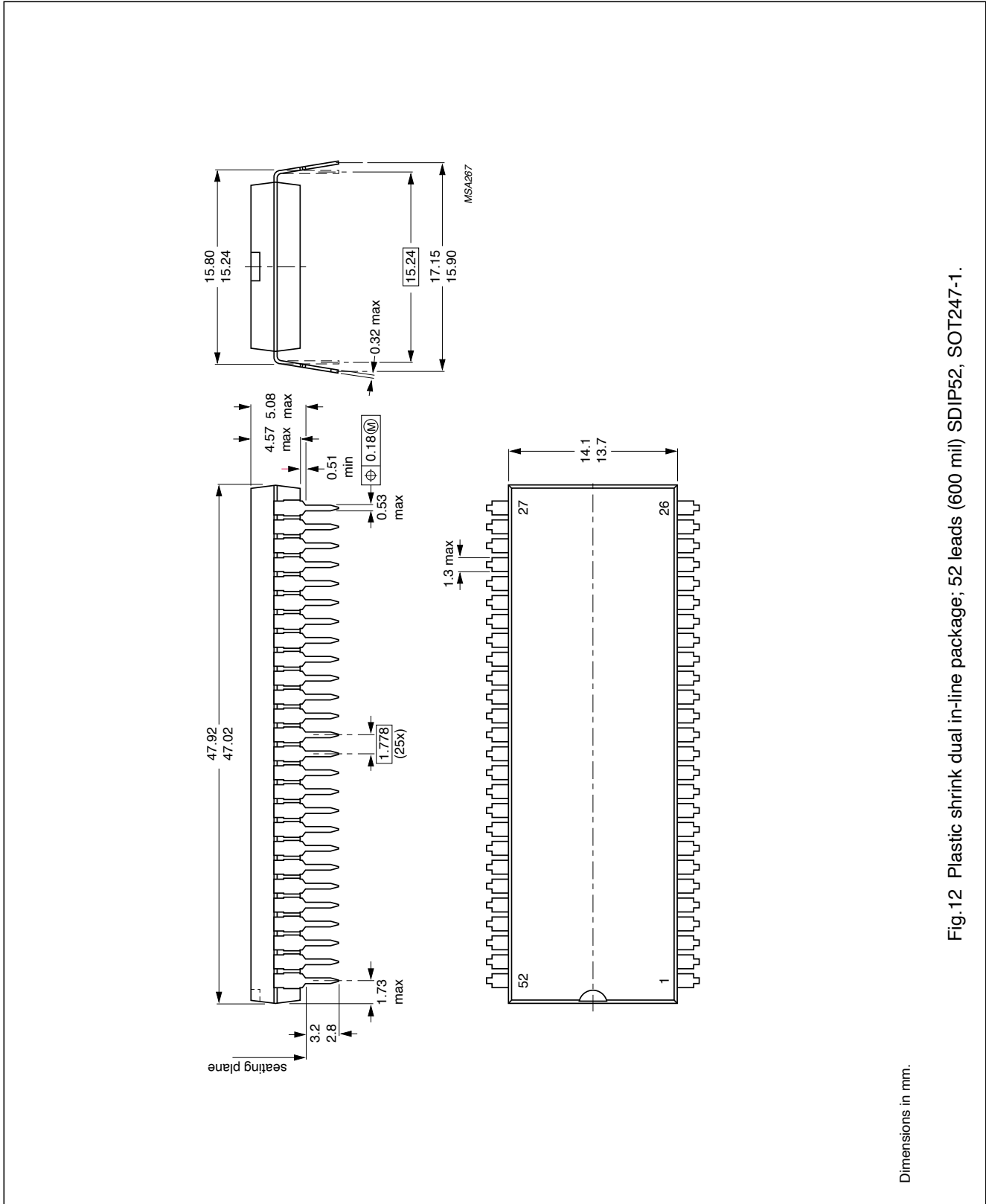

Fig.12 Plastic shrink dual in-line package; 52 leads (600 mil) SDIP52, SOT247-1.

One page Economy Teletext/TV microcontroller

SAA5290

SOLDERING

Plastic dual in-line packages

BY DIP OR WAVE

The maximum permissible temperature of the solder is 260 °C; this temperature must not be in contact with the joint for more than 5 s. The total contact time of successive solder waves must not exceed 5 s.

The device may be mounted up to the seating plane, but the temperature of the plastic body must not exceed the

specified storage maximum. If the printed-circuit board has been pre-heated, forced cooling may be necessary immediately after soldering to keep the temperature within the permissible limit.

REPAIRING SOLDERED JOINTS

Apply the soldering iron below the seating plane (or not more than 2 mm above it). If its temperature is below 300 °C, it must not be in contact for more than 10 s; if between 300 and 400 °C, for not more than 5 s.

DEFINITIONS

Data sheet status	
Objective specification	This data sheet contains target or goal specifications for product development.
Preliminary specification	This data sheet contains preliminary data; supplementary data may be published later.
Product specification	This data sheet contains final product specifications.
Limiting values	
Limiting values given are in accordance with the Absolute Maximum Rating System (IEC 134). Stress above one or more of the limiting values may cause permanent damage to the device. These are stress ratings only and operation of the device at these or at any other conditions above those given in the Characteristics sections of the specification is not implied. Exposure to limiting values for extended periods may affect device reliability.	
Application information	
Where application information is given, it is advisory and does not form part of the specification.	

LIFE SUPPORT APPLICATIONS

These products are not designed for use in life support appliances, devices, or systems where malfunction of these products can reasonably be expected to result in personal injury. Philips customers using or selling these products for use in such applications do so at their own risk and agree to fully indemnify Philips for any damages resulting from such improper use or sale.

PURCHASE OF PHILIPS I²C COMPONENTS



Purchase of Philips I²C components conveys a license under the Philips' I²C patent to use the components in the I²C system provided the system conforms to the I²C specification defined by Philips. This specification can be ordered using the code 9398 393 40011.